



**Strata CIX40, CIX100-S, CIX100,  
CIX200, CIX670, and CIX1200  
General Description**

# Publication Information

**Toshiba America Information Systems, Inc.**  
**Telecommunication Systems Division**

## **Publication Information**

Toshiba America Information Systems, Inc., Telecommunication Systems Division, reserves the right, without prior notice, to revise this information publication for any reason, including, but not limited to, utilization of new advances in the state of technical arts or to simply change the design of this document.

Further, Toshiba America Information Systems, Inc., Telecommunication Systems Division, also reserves the right, without prior notice, to make such changes in equipment design or components as engineering or manufacturing methods may warrant.

CIX-GD-ALL-VJ  
Version J.1, May 2009  
4010487

Our mission to publish accurate, complete and user accessible documentation. At the time of printing the information in this document was as accurate and current as was reasonably possible. However, in the time required to print and distribute this manual additions, corrections or other changes may have been made. To view the latest version of this or other documents please refer to the Toshiba FYI web site.

Toshiba America Information Systems shall not be liable for any commercial losses, loss of revenues or profits, loss of goodwill, inconvenience, or exemplary, special, incidental, indirect or consequential damages whatsoever, or claims of third parties, regardless of the form of any claim that may result from the use of this document.

THE SPECIFICATIONS AND INFORMATION PROVIDED HEREIN ARE FOR INFORMATIONAL PURPOSES ONLY AND ARE NOT A WARRANTY OF ACTUAL PERFORMANCE, WHETHER EXPRESSED OR IMPLIED. THE SPECIFICATIONS AND INFORMATION ARE SUBJECT TO CHANGE WITHOUT NOTICE. ACTUAL PERFORMANCE MAY VARY BASED ON INDIVIDUAL CONFIGURATIONS, USE OF COLLATERAL EQUIPMENT, OR OTHER FACTORS.

## **© Copyright 2003~2009**

This document is copyrighted by Toshiba America Information Systems, Inc. with all rights reserved. Under the copyright laws, this document cannot be reproduced in any form or by any means—graphic, electronic, or mechanical, including recording, taping, photocopying, without prior written permission of Toshiba. No patent liability is assumed, however, with respect to the use of the information contained herein.

## **Trademarks**

Strata, SmartMedia, SD (Secure Digital) and CIX are registered trademarks of Toshiba Corporation.

Stratagy, eManager, My Phone Manager and Info Manager are registered trademarks of Toshiba America Information Systems, Inc.

Windows and Microsoft are registered trademarks of Microsoft.

Trend Micro and PC-cillin are registered trademarks of Trend Micro Inc.

Norton Anti-Virus is a registered trademark of Symantec Corp.

McAfee and Virusscan are registered trademarks of McAfee, Inc.

Trademarks, registered trademarks, and service marks are the property of their respective owners.

## Strata CIX General End User Information

The Strata CIX40, CIX100, CIX200, CIX670, and CIX1200 Business Telephone System is registered in accordance with the provisions of Part 68 of the Federal Communications Commission's Rules and Regulations.

### FCC Requirements

**Means of Connection:** The Federal Communications Commission (FCC) has established rules which permit the Strata CIX system to be connected directly to the telephone network. Connection points are provided by the telephone company—connections for this type of customer-provided equipment will not be provided on coin lines. Connections to party lines are subject to state tariffs.

**Incidence of Harm:** If the system is malfunctioning, it may also be disrupting the telephone network. The system should be disconnected until the problem can be determined and repaired. If this is not done, the telephone company may temporarily disconnect service. If possible, they will notify you in advance, but, if advance notice is not practical, you will be notified as soon as possible. You will be informed of your right to file a complaint with the FCC.

**Service or Repair:** For service or repair, contact your local Toshiba telecommunications distributor. To obtain the nearest Toshiba telecommunications distributor in your area, log onto [www.toshiba.com/taistsd/pages/support\\_dealerlocator.html](http://www.toshiba.com/taistsd/pages/support_dealerlocator.html) or call (800) 222-5805 and ask for a Toshiba Telecom Dealer.

**Telephone Network Compatibility:** The telephone company may make changes in its facilities, equipment, operations, and procedures. If such changes affect the compatibility or use of the Strata CIX40, CIX100, CIX200, CIX670 or CIX1200 system, the telephone company will notify you in advance to give you an opportunity to maintain uninterrupted service.

**Notification of Telephone Company:** Before connecting a Strata CIX system to the telephone network, the telephone company may request the following:

1. Your telephone number.
2. FCC and ACTA registration
  - Strata CIX40, CIX100, CIX200, CIX670 or CIX1200 may be configured as a Key, Hybrid or PBX telephone system. The appropriate configuration for your system is dependent upon your operation of the system.
  - If the operation of your system is only manual selection of outgoing lines, it may be registered as a Key telephone system.
  - If your operation requires automatic selection of outgoing lines, such as dial access, Least Cost Routing, Pooled Line Buttons, etc., the system must be registered as a Hybrid telephone system. In addition to the above, certain features (tie Lines, Off-premises Stations, etc.) may also require Hybrid telephone system registration in some areas.
  - If you are unsure of your type of operation and/or the appropriate FCC registration number, contact your local Toshiba telecommunications distributor for assistance.

FCC Registration Numbers			
SYSTEM	PBX Fully-protected PBXs	Hybrid Fully-protected multifunction systems	KEY Fully-protected telephone key systems
CIX40	CJ6-PF03BDTCHS402	CJ6-MF03BDTCHS402	CJ6-KD03BDTCHS402
CIX100, CIX670 and CIX1200	CJ6-MUL-35931-PF-E	CJ6-MUL-35930-MF-E	CJ6-MUL-35929-KF-E
CIX200	CJ6-PF03BDTCHS192	CJ6-MF03BDTCHS192	CJ6-KD03BDTCHS192

- Ringer equivalence number: 0.3B. The ringer equivalence number (REN) is useful to determine the quantity of devices which you may connect to your telephone line and still have all of those devices ring when your number is called. In most areas, but not all, the sum of the RENs of all devices connected to one line should not exceed five (5.0B). To be certain of the number of devices you may connect to your line, as determined by the REN, you should contact your local telephone company to ascertain the maximum REN for your calling area.

3. Network connection information USOC jack required: RJ11/14C, RJ21/2E/2F/2G/2HX/RJ49C (see Network Requirements in this document). Items 2, 3 and 4 are also indicated on the equipment label.
4. Authorized Network Parts: 02LS2/GS2, 02RV2-T/O, OL13C/B, T11/12/31/32M, 04DU9-BN/DN/1SN, 02IS5, 04DU9-BN/DN/1SN1ZN

### Radio Frequency Interference

Warning: This equipment generates, uses, and can radiate radio frequency energy and if not installed and used in accordance with the manufacturer's instruction manual, may cause interference to radio communications. It has been tested and found to comply with the limits for a Class A computing device pursuant to Subpart J of Part 15 of FCC Rules, which are designed to provide reasonable protection against such interference when operated in a commercial environment. Operation of this equipment in a residential area is likely to cause interference, in which case, the user, at his/her own expense, will be required to take whatever measures may be required to correct the interference.

### Underwriters Laboratory

This system is listed with Underwriters Laboratory (UL). Secondary protection is required, on any wiring from any telephone that exits the building or is subject to lightning or other electrical surges, and on DID, OPS, and Tie lines. (Additional information is provided in this manual.)



### Important Notice — Music-On-Hold

In accordance with U.S. Copyright Law, a license may be required from the American Society of Composers, Authors and Publishers, or other similar organization, if radio or TV broadcasts are transmitted through the music-on-hold feature of this telecommunication system. Toshiba America Information Systems, Inc., strongly recommends not using radio or television broadcasts and hereby disclaims any liability arising out of the failure to obtain such a license.

CP01, Issue 8, Part I Section 14.1

Notice: The Industry Canada label identifies certified equipment. This certification means that the equipment meets certain telecommunications network protective, operational and safety requirements as prescribed in the appropriate Terminal Equipment Technical Requirements document(s). The Department does not guarantee the Equipment will operate to the user's satisfaction.

Before installing this equipment, users should ensure that it is permissible to be connected to the facilities of the local telecommunications company. The equipment must also be installed using an acceptable method of connection. The customer should be aware that compliance with the above conditions may not prevent degradation of service in some situations.

Repairs to certified equipment should be coordinated by a representative designated by the supplier. Any repairs or alterations made by the user to this equipment, or equipment malfunctions, may give the telecommunications company cause to request the user to disconnect the equipment.

Users should ensure for their own protection that the electrical ground connections of the power utility, telephone lines and internal metallic water pipe system, if present, are connected together. This precaution may be particularly important in rural areas.

---

**CAUTION! Users should not attempt to make such connections themselves, but should contact the appropriate electric inspection authority, or electrician, as appropriate.**

---

CP01, Issue 8, Part I Section 14.2

Ringer Equivalence Notice: The Ringer Equivalence Number (REN) assigned to each terminal device provides an indication of the maximum number of terminals allowed to be connected to a telephone interface. The terminal on an interface may consist of any combination of devices subject only to the requirement that the sum of the Ringer Equivalence Numbers of all the Devices does not exceed 5.

Hearing Aid Compatibility Notice: The FCC has established rules that require all installed business telephones be hearing aid compatible. This rule applies to all telephones regardless of the date of manufacture or installation. There are severe financial penalties which may be levied on the end-user for non-compliance.

# **TOSHIBA AMERICA INFORMATION SYSTEMS, INC. ("TAIS")**

## **Telecommunication Systems Division License Agreement**

IMPORTANT: THIS LICENSE AGREEMENT ("AGREEMENT") IS A LEGAL AGREEMENT BETWEEN YOU ("YOU") AND TAIS. CAREFULLY READ THIS LICENSE AGREEMENT. USE OF ANY SOFTWARE OR ANY RELATED INFORMATION (COLLECTIVELY, "SOFTWARE") INSTALLED ON OR SHIPPED WITH A TAIS DIGITAL SOLUTIONS PRODUCT OR OTHERWISE MADE AVAILABLE TO YOU BY TAIS IN WHATEVER FORM OR MEDIA, WILL CONSTITUTE YOUR ACCEPTANCE OF THESE TERMS, UNLESS SEPARATE TERMS ARE PROVIDED BY THE SOFTWARE SUPPLIER. IF YOU DO NOT AGREE WITH THE TERMS OF THIS LICENSE AGREEMENT, DO NOT INSTALL, COPY OR USE THE SOFTWARE AND PROMPTLY RETURN IT TO THE LOCATION FROM WHICH YOU OBTAINED IT IN ACCORDANCE WITH APPLICABLE RETURN POLICIES. EXCEPT AS OTHERWISE AUTHORIZED IN WRITING BY TAIS, THIS SOFTWARE IS LICENSED FOR DISTRIBUTION THROUGH TAIS AUTHORIZED CHANNELS ONLY TO END-USERS PURSUANT TO THIS LICENSE AGREEMENT.

- 1. License Grant.** The Software is not sold; it is licensed upon payment of applicable charges. TAIS grants to you a personal, non-transferable and non-exclusive right to use the copy of the Software provided under this License Agreement. You agree you will not copy the Software except as necessary to use it on one TAIS system at a time at one location. Modifying, translating, renting, copying, distributing, printing, sublicensing, transferring or assigning all or part of the Software, or any rights granted hereunder, to any other persons and removing any proprietary notices, labels or marks from the Software is strictly prohibited except as permitted by applicable law; you agree violation of such restrictions will cause irreparable harm to TAIS and provide grounds for injunctive relief, without notice, against you or any other person in possession of the Software. You and any other person whose possession of the software violates this License Agreement shall promptly surrender possession of the Software to TAIS, upon demand. Furthermore, you hereby agree not to create derivative works based on the Software. TAIS reserves the right to terminate this license and to immediately repossess the software in the event that you or any other person violates this License Agreement. Execution of the Software for any additional capabilities require a valid run-time license.
- 2. Intellectual Property.** You acknowledge that no title to the intellectual property in the Software is transferred to you. You further acknowledge that title and full ownership rights to the Software will remain the exclusive property of TAIS and/or its suppliers, and you will not acquire any rights to the Software, except the license expressly set forth above. You will not remove or change any proprietary notices contained in or on the Software. The Software is protected under US patent, copyright, trade secret, and/or other proprietary laws, as well as international treaties. Any transfer, use, or copying of the software in violation of the License Agreement constitutes copyright infringement. You are hereby on notice that any transfer, use, or copying of the Software in violation of this License Agreement constitutes a willful infringement of copyright.
- 3. No Reverse Engineering.** You agree that you will not attempt, and if you employ employees or engage contractors, you will use your best efforts to prevent your employees and contractors from attempting to reverse compile, reverse engineer, modify, translate or disassemble the Software in whole or in part. Any failure to comply with the above or any other terms and conditions contained herein will result in the automatic termination of this license and the reversion of the rights granted hereunder back to TAIS.
- 4. Limited Warranty.** THE SOFTWARE IS PROVIDED "AS IS" WITHOUT WARRANTY OF ANY KIND. TO THE MAXIMUM EXTENT PERMITTED BY APPLICABLE LAW, TAIS AND ITS SUPPLIERS DISCLAIM ALL WARRANTIES WITH REGARD TO THE SOFTWARE, EITHER EXPRESS OR IMPLIED, INCLUDING, BUT NOT LIMITED TO, THE WARRANTY OF NON-INFRINGEMENT OF THIRD PARTY RIGHTS, THE WARRANTY OF YEAR 2000 COMPLIANCE, AND THE IMPLIED WARRANTIES OF MERCHANTABILITY AND FITNESS FOR A PARTICULAR PURPOSE. THE ENTIRE RISK AS TO THE QUALITY AND PERFORMANCE OF THE SOFTWARE IS WITH YOU. NEITHER TAIS NOR ITS SUPPLIERS WARRANT THAT THE FUNCTIONS CONTAINED IN THE SOFTWARE WILL MEET YOUR REQUIREMENTS OR THAT THE OPERATION OF THE SOFTWARE WILL BE UNINTERRUPTED OR ERROR-FREE. HOWEVER, TAIS WARRANTS THAT ANY MEDIA ON WHICH THE SOFTWARE IS FURNISHED IS FREE FROM DEFECTS IN MATERIAL AND WORKMANSHIP UNDER NORMAL USE FOR A PERIOD OF NINETY (90) DAYS FROM THE DATE OF DELIVERY TO YOU.
- 5. Limitation Of Liability.** TAIS' ENTIRE LIABILITY AND YOUR SOLE AND EXCLUSIVE REMEDY UNDER THIS LICENSE AGREEMENT SHALL BE AT TAIS' OPTION REPLACEMENT OF THE MEDIA OR REFUND OF THE PRICE PAID. TO THE MAXIMUM EXTENT PERMITTED BY APPLICABLE LAW, IN NO EVENT SHALL TAIS OR ITS SUPPLIERS BE LIABLE TO YOU FOR ANY CONSEQUENTIAL, SPECIAL, INCIDENTAL OR INDIRECT DAMAGES FOR PERSONAL INJURY, LOSS OF BUSINESS PROFITS, BUSINESS INTERRUPTION, LOSS OF BUSINESS INFORMATION/DATA, OR ANY OTHER PECUNIARY LOSS OF ANY KIND ARISING OUT OF THE USE OR INABILITY TO USE THE SOFTWARE, EVEN IF TAIS OR ITS SUPPLIER HAS BEEN ADVISED OF THE POSSIBILITY OF SUCH DAMAGES. IN NO EVENT SHALL TAIS OR ITS SUPPLIERS BE LIABLE FOR ANY CLAIM BY A THIRD PARTY.
- 6. State/Jurisdiction Laws.** SOME STATES/JURISDICTIONS DO NOT ALLOW THE EXCLUSION OF IMPLIED WARRANTIES OR LIMITATIONS ON HOW LONG AN IMPLIED WARRANTY MAY LAST, OR THE EXCLUSION OR LIMITATION OF INCIDENTAL OR CONSEQUENTIAL DAMAGES, SO SUCH LIMITATIONS OR EXCLUSIONS MAY NOT APPLY TO YOU. THIS LIMITED WARRANTY GIVES YOU SPECIFIC RIGHTS AND YOU MAY ALSO HAVE OTHER RIGHTS WHICH VARY FROM STATE/JURISDICTION TO STATE/JURISDICTION.
- 7. Export Laws.** This License Agreement involves products and/or technical data that may be controlled under the United States Export Administration Regulations and may be subject to the approval of the United States Department of Commerce prior to export. Any export, directly or indirectly, in contravention of the United States Export Administration Regulations, or any other applicable law, regulation or order, is prohibited.
- 8. Governing Law.** This License Agreement will be governed by the laws of the State of California, United States of America, excluding its conflict of law provisions.
- 9. United States Government Restricted Rights.** The Software is provided with Restricted Rights. The Software and other materials provided hereunder constitute Commercial Computer Software and Software Documentation and Technical Data related to Commercial Items. Consistent with F.A.R. 12.211 and 12.212 they are licensed to the U.S. Government under, and the U.S. Government's rights therein are restricted pursuant to, the vendor's commercial license.
- 10. Severability.** If any provision of this License Agreement shall be held to be invalid, illegal or unenforceable, the validity, legality and enforceability of the remaining provisions hereof shall not in any way be affected or impaired.
- 11. No Waiver.** No waiver of any breach of any provision of this License Agreement shall constitute a waiver of any prior, concurrent or subsequent breach of the same or any other provisions hereof, and no waiver shall be effective unless made in writing and signed by an authorized representative of the waiving party.
- 12. Supplier Software.** The Software may include certain software provided by TAIS suppliers. In such event, you agree that such supplier may be designated by TAIS as a third party beneficiary of TAIS with rights to enforce the Agreement with respect to supplier's software.

YOU ACKNOWLEDGE THAT YOU HAVE READ THIS LICENSE AGREEMENT AND THAT YOU UNDERSTAND ITS PROVISIONS. YOU AGREE TO BE BOUND BY ITS TERMS AND CONDITIONS. YOU FURTHER AGREE THAT THIS LICENSE AGREEMENT CONTAINS THE COMPLETE AND EXCLUSIVE AGREEMENT BETWEEN YOU AND TAIS AND SUPERSEDES ANY PROPOSAL OR PRIOR AGREEMENT, ORAL OR WRITTEN, OR ANY OTHER COMMUNICATION RELATING TO THE SUBJECT MATTER OF THIS LICENSE AGREEMENT.

**Toshiba America Information Systems, Inc.**  
**Telecommunication Systems Division**  
**9740 Irvine Boulevard**  
**Irvine, California 92618-1697**  
**United States of America**

5932

DSD 020905

**Toshiba America Information Systems, Inc.**  
**Telecommunication Systems Division**  
**End-User Limited Warranty**

Toshiba America Information Systems, Inc., ("TAIS") warrants that this telephone equipment manufactured by Toshiba (except for fuses, lamps, and other consumables) will, upon delivery by TAIS or an authorized TAIS dealer to a retail customer in new condition, be free from defects in material and workmanship for twenty-four (24) months after delivery, except as otherwise provided by TAIS in the TAIS warranty accompanying the products or posted on TAIS's website. Products which are not manufactured by Toshiba but are purchased from Toshiba, will be subject to the warranty provisions provided by the equipment manufacturer, unless TAIS notifies the end-user of any additional warranty provisions in writing.

This warranty is void (a) if the equipment is used under other than normal use and maintenance conditions, (b) if the equipment is modified or altered, unless the modification or alteration is expressly authorized by TAIS, (c) if the equipment is subject to abuse, neglect, lightning, electrical fault, or accident, (d) if the equipment is repaired by someone other than TAIS or an authorized TAIS dealer, (e) if the equipment's serial number is defaced or missing, or (f) if the equipment is installed or used in combination or in assembly with products not supplied by TAIS and which are not compatible or are of inferior quality, design, or performance.

The sole obligation of TAIS or Toshiba Corporation under this warranty, or under any other legal obligation with respect to the equipment, is the repair or replacement of such defective or missing parts as are causing the malfunction by TAIS or its authorized dealer with new or refurbished parts (at their option). If TAIS or one of its authorized dealers does not replace or repair such parts, the retail customer's sole remedy will be a refund of the price charged by TAIS to its dealers for such parts as are proven to be defective, and which are returned to TAIS through one of its authorized dealers within the warranty period and no later than thirty (30) days after such malfunction, whichever first occurs.

Under no circumstances will the retail customer or any user or dealer or other person be entitled to any direct, special, indirect, consequential, or exemplary damages, for breach of contract, tort, or otherwise. Under no circumstances will any such person be entitled to any sum greater than the purchase price paid for the item of equipment that is malfunctioning.

To obtain service under this warranty, the retail customer must bring the malfunction of the machine to the attention of one of TAIS' authorized dealers within the applicable warranty period and no later than thirty (30) days after such malfunction, whichever first occurs. Failure to bring the malfunction to the attention of an authorized TAIS dealer within the prescribed time results in the customer being not entitled to warranty service.

THERE ARE NO OTHER WARRANTIES FROM EITHER TOSHIBA AMERICA INFORMATION SYSTEMS, INC., OR TOSHIBA CORPORATION WHICH EXTEND BEYOND THE FACE OF THIS WARRANTY. ALL OTHER WARRANTIES, EXPRESS OR IMPLIED, INCLUDING THE WARRANTIES OF MERCHANTABILITY, FITNESS FOR A PARTICULAR PURPOSE, AND FITNESS FOR USE, ARE EXCLUDED.

No TAIS dealer and no person other than an officer of TAIS may extend or modify this warranty. No such modification or extension is effective unless it is in writing and signed by the Vice President and General Manager, Telecommunication Systems Division.

# **WARRANTIES FOR NON-TOSHIBA BRANDED THIRD PARTY PRODUCTS**

A valuable element of Toshiba's product strategy is to offer our customers a complete product portfolio. To provide this value to our customers at the most optimal prices, we offer both Toshiba-branded and third-party manufactured products that support our Toshiba Strata CIX product portfolio. Similar to other resellers of software, hardware and peripherals, these third-party manufactured products carry warranties independent of our Toshiba limited warranty provided with our Toshiba-branded products. Customers should note that third-party manufacturer warranties vary from product to product and are covered by the warranties provided through the original manufacturer and passed on intact to the purchaser by Toshiba. Customers should consult their product documentation for third-party warranty information specific to third-party products. More information may also be available in some cases from the manufacturer's public website.

While Toshiba offers a wide selection of software, hardware and peripheral products, we do not specifically test or guarantee that the third-party products we offer work under every configuration with any or all of the various models of the Toshiba Strata CIX. Toshiba does not endorse, warrant nor assume any liability in connection with such third party products or services. If you have questions about compatibility, we recommend and encourage you to contact the third-party software, hardware and peripheral product manufacturer directly.

This page is intentionally left blank.



# Contents

---

## Introduction

- Organization ..... ix
- Conventions ..... x
- Related Documents/Media ..... xi

## Chapter 1 – Strata CIX Overview

### Chapter 2 – Strata CIX40

- Processor ..... 4
- CIX40 Cabinet Slots ..... 5
  - Large Scale Integrated (LSI) Circuits (no licenses required) ..... 5
  - GCTU2A Processor Interfaces ..... 6
- GVPH – Integrated Voice Mail ..... 7
- Feature Compatibility ..... 7
- System Configuration ..... 8
  - Reserve Power ..... 11
- Telephone and Console Support ..... 11
- CIX40 Functional Block Diagram ..... 12
- Additional Specifications ..... 13
- Station Loop Limits ..... 14

### Chapter 3 – Strata CIX100-S / CIX100

- CIX100-S and CIX100 Processors ..... 16
  - CPU/Memory ..... 16
  - Large Scale Integrated (LSI) Circuits ..... 16
  - Memory Protection Battery ..... 16
  - Relay Control Interface ..... 16
  - External Page Interface ..... 16
  - Music-on-hold/Background Music Interface ..... 16
  - Secure Digital Memory ..... 16
  - Built-in Ethernet Connection ..... 17
  - CIX100 Processor Optional Subassemblies ..... 17
- CIX100 Cabinet Slots ..... 17
  - Base Cabinet ..... 17
  - Expansion Cabinets ..... 17

### Chapter 4 – Strata CIX200

- Base Cabinet ..... 19
- Expansion Cabinets ..... 19
- Basic Specifications ..... 20

Power Backup .....	20
Configuration .....	21
Card Slot Use .....	21
Power Factor .....	21
CIX200 PCBs .....	22
PCB Option Considerations .....	22
Common Control Processor Unit (LCTU) .....	22
Analog Standard Station Interface Unit (LSLU1A) .....	23
Modular or Amphenol Connections .....	23
Extenders .....	23

## Chapter 5 – Strata CIX670 and CIX1200

Strata CIX670 .....	25
CIX670 Processor Circuit Cards .....	26
CPU/Memory .....	26
Large-scale Integrated (LSI) circuits .....	26
Memory Protection Battery .....	26
Music-on-hold/Background Music Interface .....	26
Secure Digital (SD) Memory .....	26
Network Interface .....	27
CIX670 Processor Optional Subassemblies .....	27
Strata CIX1200 .....	28
CIX1200 Processor Circuit Cards .....	29
CPU/Memory .....	29
Large-scale Integrated (LSI) circuits .....	29
Memory Protection Battery .....	29
Music-on-hold/Background Music Interface .....	29
Secure Digital (SD) Memory .....	29
Network Interface .....	30
CIX1200 Processor Optional Subassemblies .....	30
CIX670 and CIX1200 Cabinet Slots .....	31
Base Cabinet .....	31
Expansion Cabinets .....	31
Strata CIX670 and CIX1200 Rack Mount .....	32
Basic Specifications .....	32
Base Cabinet .....	33
Expansion cabinet .....	33
CIX670 and CIX1200 Remote Expansion Cabinet .....	34

## Chapter 6 – Universal Slot Circuit Cards

Station, Line and Option Circuit Cards .....	35
Functional Block Diagrams .....	40

## Chapter 7 – Telephones and Peripherals

DP5000-series Digital Telephones .....	45
The DP5000 Look .....	48
Large Display Area for Call Information .....	48
LCD Key-Strip .....	48
Backlight LCD .....	48

- Mic Mute ..... 49
- Handset/Headset ..... 49
- Shift and Hist Keys ..... 49
- Speaker Off-hook Call Announce (DOCA-1A) ..... 49
- DP5000-Series Telephone Tilt Angles ..... 50
- Telephone Button Expansion Options ..... 51
  - LCD Add-on -Module (LM5110) ..... 51
  - Key Module (KM5020) ..... 51
  - Digital DSS Add on Module (DDM5060) ..... 51
- Cordless Digital Telephones ..... 52
  - DKT2404-DECT ..... 53
  - DKT2204-CT ..... 53
  - DKT2304-CT ..... 53
- IP 5000-Series IP Telephones ..... 54
  - Features ..... 56
  - IP Protocol ..... 56
  - Connectivity ..... 57
  - Capabilities ..... 57
  - Liquid Crystal Display (LCD) Models ..... 58
- Telephone Button Expansion Options ..... 59
  - LCD Add-on Module (LM5110) ..... 59
  - Key Module (KM5020) ..... 59
  - IP Direct Station Selection (IDM5060) Console ..... 59
- CIX Attendant Console ..... 60
- Peripherals ..... 63
  - Door Phone (MDFB) ..... 63
  - Door Phone/Lock Control Unit (DDCB) ..... 63
  - External Speaker (BESCB) ..... 63
- Mobility Solutions ..... 64
  - SoftIPT ..... 64
  - Wireless Access Points ..... 64
  - VPN/Firewall Solutions from SonicWALL ..... 65
  - Power-Over-Ethernet Solutions from SMC ..... 65
- Video Communication Solution ..... 66
  - Visual Collaboration ..... 66
  - Try VCS for FREE ..... 66
  - VCS Features ..... 66
  - Software ..... 67
  - VCS Software Upgrade ..... 67
  - Licenses ..... 67
- Product Specifications ..... 68
- Toshiba Stratagy Voice Processing ..... 69
- Cabling and Connectors ..... 70

**Chapter 8 – Strata Media Application Server and Integrated Voice Mail Cards**

- Strata Media Application Server (MAS) ..... 71
  - 2U Rackmount Platform ..... 71
  - MicroMAS ..... 72
  - Standard Software Applications ..... 72

Optional Software Applications .....	73
Connection to the Strata CIX .....	73
Preloaded Software .....	74
Windows XP Firewall Settings .....	74
MAS Configuration Requirements .....	74
Approved Third Party Application Software .....	75
Maximum MAS Configurations .....	75
MAS Licensing .....	78
MAS Recovery .....	79
MAS Software Backup .....	79
MAS Modem (Optional) .....	79
Input Power .....	80
Power Failure Backup .....	80
Grounding .....	80
Connection .....	80
Physical Specifications .....	81
Basic MAS Specifications .....	81
MicroMAS .....	82
Unified System Administration .....	83
eManager® or Network eManager unifies Strata CIX and Strategy ES System Administration ..	83
Network eManager .....	83
My Phone Manager Gives Telephone Programming to Individual End-Users .....	84
All Features to All Users No Matter Where They Are .....	85
FeatureFlex Next Generation Adaptability .....	85
LVMU1A Voice Mail Card .....	88
Features .....	88
Licenses .....	88
Software .....	88
Port Upgrades .....	89
GVPH1A Voice Mail Card .....	89
Other Voice Processing Systems .....	89

## Chapter 9 – Features

Account Codes .....	91
Add-on Module (ADM) .....	91
Advisory Messages .....	91
Alarm Notification .....	92
Alternate Answer Point .....	92
Automatic Busy Redial .....	92
Automatic Call Distribution (ACD) Server .....	92
Basic ACD Features .....	93
Enhanced ACD Features .....	93
Automatic Callback (ACB) .....	94
Automatic Line Selection .....	94
Automatic Release .....	95
Automatic Release from Hold .....	95
Automatic Release of Incoming Calls .....	95
Station Automatic Release .....	95
Background Music (BGM) .....	95
Call Completion .....	95

Call Forward .....	96
Station Call Forward .....	96
System Call Forward .....	96
Call Forward Conditions .....	97
Call Forward Destination .....	97
Call Forward – Call Types .....	97
Call Forward Remote .....	97
Call History .....	98
Call Monitoring and Transfer .....	98
Call Park .....	99
Call Park Orbits .....	99
Park and Page .....	99
Call Pickup .....	99
Call Waiting .....	100
Caller Identification .....	101
ISDN Calling ID Name and Number .....	101
Camp on Busy .....	101
Automatic Camp On .....	101
Off-hook Camp On .....	102
Cancel Button .....	102
Centrex/PBX Compatible .....	102
Centrex Ringing Repeat .....	102
Classes of Service (COS) .....	103
Computer Telephony Integration (CTI) .....	103
Conference Calls .....	103
Conference On-Hold .....	103
Join Button .....	103
Split/Join/Drop .....	103
Releasing from Conference Tandem CO Line Connections .....	104
Voice Mail Conference .....	104
Continuous DTMF Tone .....	104
Credit Card Calling .....	104
Data Privacy .....	104
Day/Night Mode – Auto Schedule .....	105
Delayed Ringing .....	106
Destination (Toll) Restriction .....	106
Through Dialing .....	106
Dial Directory .....	106
Direct Inward Dialing (DID) .....	107
Dialed Number Identification Service (DNIS) .....	107
Digital Pad .....	108
Direct Inward System Access (DISA) .....	108
Directory Numbers .....	109
Primary [DN] Buttons .....	109
Phantom [DN] Buttons .....	109
Pilot [DN] .....	109
Distinctive LED Indicator .....	109
Distinctive Ringing .....	110
Do Not Disturb (DND) .....	110
Direct Station Selection (DSS) Buttons .....	110

[DSS] Button Status Display .....	110
DTMF Receivers .....	111
DTMF Back Tone .....	111
DTMF and Dial Pulse CO Line Compatibility .....	111
DTMF Signal Time .....	111
Emergency Call .....	111
Feature Prompting with Soft Keys .....	111
Enhanced E911 .....	112
External Amplified Speaker .....	112
Flash Button .....	112
Flexible Line Ringing .....	113
Flexible Numbering .....	113
Handsfree Answerback .....	113
Headset .....	113
Hearing Aid Compatible .....	113
High Call Volume Buttons .....	113
Hold .....	114
Automatic Hold .....	114
Analog Hold .....	114
Call Hold .....	114
Consultation Hold .....	114
Exclusive Hold .....	114
Hold Recall .....	114
Hot Dialing .....	114
Hot Desk .....	115
Hot Desk Requirements .....	116
Hotline Service .....	116
IP Telephony .....	117
Data Network Assessment for Voice Traffic .....	117
IP Interface Unit .....	117
Network Address Translation (NAT) .....	120
IP User Mobility .....	122
IPT Anywhere .....	123
Quality of Service (QoS) and Bandwidth .....	124
Power Over Ethernet .....	125
Toshiba SoftIPT IP Telephone .....	126
Private Networking Over Internet Protocol .....	128
SIP Trunking .....	129
Integrated Services Digital Network (ISDN) .....	130
Least Cost Routing (LCR) .....	130
Line Buttons .....	131
CO Line Buttons .....	131
Pooled CO Line Button .....	131
Group CO Line Button .....	131
Live System Programming .....	131
Lost Call Treatment .....	131
Message Waiting .....	132
LED Indication .....	132
Stutter Dial Tone .....	132
Microphone (External Unit) .....	132

Music-on-hold ..... 132

Multiple Call/Delayed Ringing ..... 132

Off-Hook Call Announce (OCA) ..... 133

Off-Premise Stations ..... 133

Override ..... 134

    Call Forward Override ..... 134

    Class Of Service Override ..... 134

    Do Not Disturb (DND) Override ..... 134

    Executive Override ..... 134

    Privacy Override ..... 134

Paging ..... 135

    Telephone Group Paging ..... 135

    External Speaker Page Zones ..... 135

    Emergency Page ..... 135

    Night Ringing Over Selected Page Zones ..... 135

Power Failure Protection ..... 136

    Power Failure Transfer ..... 136

    Reserve Power Battery Backup ..... 136

Privacy ..... 136

Remote Update ..... 136

Repeat Last Number Dialed ..... 137

Ringling ..... 137

    Ring Over Busy ..... 137

    Ringling Cadence ..... 137

    Delayed Ringing ..... 137

    Distinctive Ringing ..... 137

Speed Dial ..... 138

    One Touch Buttons ..... 138

Station Hunting ..... 138

    Serial Hunting ..... 139

    Circular Hunting ..... 139

    Distributed Hunting ..... 139

    Camp on to Hunt Groups ..... 139

Station Message Detail Recording (SMDR) ..... 139

Strata Net Multi-system Networking ..... 140

    Coordinated Numbering Plan ..... 140

    Strata Net Basic Call Control ..... 140

    Alternate Routing ..... 141

    Centralized Attendant ..... 141

    Telephone DSS Buttons ..... 141

    Centralized Voice Mail ..... 141

    Network SMDR ..... 142

System Fault Finding and Diagnostics ..... 143

    Alarm Indication of System Faults ..... 143

    Secure Digital Card ..... 143

    Fault Detection and Error Logs ..... 143

    Event and System Administration Logs ..... 143

    Automatic Fault Recovery ..... 143

    System Trace ..... 143

    Manual Test ..... 144

Backup and Restore .....	144
Maintenance and Administration .....	144
Software Upgrade .....	144
Transfer .....	144
Transfer with Camp On .....	144
Transfer Immediate .....	144
Transfer Privacy .....	144
Transfer (Screened) .....	145
Transfer (Unscreened) .....	145
Transfer to Voice Mail .....	145
Music or Ringing Option .....	145
Tenant Services .....	145
Traffic Measurement .....	145
Traffic Reports .....	146
Uniform Call Distribution .....	146
Interaction with Other Features .....	146
User Programming Mode .....	148
VLAN Tagging .....	149
Voice or Tone Signaling .....	150
Voice Mail Integration .....	150
DTMF Integration .....	150
Simplified Message Desk Interface (SMDI) .....	150
Toshiba Proprietary Integration .....	151
Direct Transfer to Voice Mailbox .....	151
Volume Control .....	151

**Appendix – Specifications**

Environmental Characteristics .....	153
Power Considerations .....	154
CIX40 .....	154
CIX100 .....	154
CIX200 .....	154
CIX670 and CIX1200 .....	155
MAS Power Considerations .....	155
Reserve Power .....	156
Strata CIX Component Compatibility .....	158
Public Network Requirements .....	162
Station Loop Lengths .....	164
Standard Telephone Ringer Specifications .....	165
Standard Telephone Interface Options .....	165
5000/3000/3200-series Telephone Option Circuit Cards .....	166
Station Dimensions .....	167
System Tones .....	168
Strata Net IP and IPT Bandwidth Requirements .....	171
Strata CIX Software License Requirements .....	173
Capacities .....	177
Device Monitor Capacities for Strata CIX Systems .....	187

<b>Index</b> .....	189
--------------------	-----



# Introduction

---

This General Description provides an overview of the Strata CIX40, CIX100-S, CIX100, CIX200, CIX670, and CIX1200 IP and digital business telephone systems, associated hardware and features. The features described in this document assume that the Strata CIX/CTX system has the current software release installed.

## Organization

This document is divided into the following major topics:

- **Chapter 1 – Strata CIX Overview** is a brief introduction of the Strata CIX systems.
- **Chapter 2 – Strata CIX40** describes the system, its basic capacities and system expansion.
- **Chapter 3 – Strata CIX100-S / CIX100** describes the system, its basic capacities and system expansion.
- **Chapter 4 – Strata CIX200** describes the CIX200 system (hardware, software and circuit cards), its unique attributes and basic functionality.
- **Chapter 5 – Strata CIX670 and CIX1200** describes the system, its basic capacities, system expansion, and remote maintenance.
- **Chapter 6 – Universal Slot Circuit Cards** provide information about Printed Circuit Boards (PCBs) that can be installed in the universal slots of the Strata CIX/CTX systems.
- **Chapter 7 – Telephones and Peripherals** describes the most recent Toshiba-proprietary stations and peripherals, customer-supplied peripherals, as well as cabling and connectors.
- **Chapter 8 – Strata Media Application Server and Integrated Voice Mail Cards** describes the MAS, its basic capacities, system expansion, and remote maintenance. It also includes some information about Voice Processing systems.
- **Chapter 9 – Features** describes the features which are available system-wide, as well as stations features.
- **Appendix – Specifications** includes detailed information on environmental characteristics, power considerations, hardware compatibility, network requirements, and station specifications and system capacities.

# Conventions

Conventions	Description
<b>Note</b>	Elaborates specific items or references other information. Within some tables, general notes apply to the entire table and numbered notes apply to specific items.
<b>Important!</b>	<i>Calls attention to important instructions or information.</i>
<b>Courier</b>	Shows a computer keyboard entry or screen display.
“Type”	Indicates entry of a string of text.
“Press”	Indicates entry of a single key. For example: Type <b>prog</b> then press <b>Enter</b> .
Plus (+)	Shows a multiple PC keyboard or phone button entry. Entries without spaces between them show a simultaneous entry. Example: <b>Esc+Enter</b> . Entries with spaces between them show a sequential entry. Example: # 5.
Tilde (~)	Means “through.” Example: 350 ~ 640 Hz frequency range.
➤	Denotes a procedure.
➤	Denotes the step in a one-step procedure.
Start > Settings > Printers	Denotes a progression of buttons and/or menu options on the screen you should select.
See Figure 10	Grey/Blue words within the printed text denote cross-references. In the electronic version of this document (Library CD-ROM or FYI Internet download), cross-references appear in blue hypertext.

# Related Documents/Media

## Installation and Programming Manuals

- Strata CIX Installation & Maintenance Manual
- Strata CIX Programming Manual (Volume 1)
- Strata CIX Programming Manual (Volume 2 – Strategy ES Voice Mail Application)
- Strata CIX Programming Manual (Volume 3 – Application Implementation)
- Telephone Button Programming Manual
- Strata Record Sheets

## User Guides

- Strata CIX IP5000-Series Telephone
- Strata CIX DP5000-series Telephone
- Strata CIX IPT Telephone
- Strata CIX DP Telephone
- My Phone Manager™
- Strata CTX DKT3001/2001 Digital Single Line Telephone
- Strata CIX Standard Telephone
- Strata DKT2204-CT/DKT2304-CT Cordless Telephones

## Quick Reference Guide

- Strata CIX IP5000-Series Telephone
- Strata CIX DP5000-Series Telephone
- Strata CIX/CTX DKT/IPT Telephone

## CD-ROMs

- Strata CIX Application Software and Documentation Library – includes eManager™ software.
- Strata CIX Call Center Solutions Application Software and Documentation Library

For *authorized users*, Internet site FYI (<http://fyi.tsd.toshiba.com>) contains all current Strata CIX and CTX documentation and enables you to view, print and download current publications.

This page is intentionally left blank.

The Strata CIX family includes the CIX40, CIX100-S, CIX100, CIX200, CIX670, and CIX1200 Internet Protocol (IP) systems that provide sophisticated business communication features. These systems deliver on the promise of IP telephony by providing all the features and benefits of our traditional business communications systems on a converged IP platform. With the Strata CIX, you have a choice of mixing and matching technologies, creating a pure IP system or a converged solution, and changing based on the needs of your company.

**Important!** *The Strata CIX100-S uses the same hardware and configuration as the Strata CIX100, with a few exceptions. Whenever the CIX100 is mentioned in this book, it applies to both the CIX100-S and CIX100, unless specified otherwise.*

The Strata CIX IP business communications system provides pure IP peer-to-peer functionality, offers FeatureFlex™ adaptability capabilities, and provides a smooth migration path from Toshiba Strata CTX and Strata DK digital business communication systems.

The Strata CIX supports many types of telephones and provides the configuration flexibility to build the communications system you need, in addition to the investment protection from re-using devices from other Strata systems. That's why the Strata CIX is much more than just an IP system. It is a unified communications environment that supports many types of client devices.

Optionally available with the Strata CIX is the Strata Media Application Server (MAS), which allows multiple applications to be combined on a single device. Applications include Auto Attendant, Voice Mail, Automated Speech Recognition (ASR), Text-to-Speech, Unified Messaging, Interactive Voice Response (IVR), Automatic Call Distribution (ACD) and Reporting, Web browser-based Personal and System Administration, Web-based Telephone Applications, FeatureFlex adaptability tools, and third-party applications. For more information on the MAS, please refer to [Chapter 8 – Strata Media Application Server and Integrated Voice Mail Cards](#).

This page is intentionally left blank.

This chapter provides a system overview of the Strata CIX40 telephone system.

The CIX40 is an IP communication system that brings powerful IP telephony and Strata Net networking capabilities to small customers and branch office locations.

The Strata CIX40 system is a compact system that provides large system features (for dimensions, see [Table 1](#)). The CIX40 is designed for wall mounting and occupies very little space.

An optional 4~8 port, 40-hour integrated plug and play Toshiba Voice Processing system (GVPH1A) with built-in modem plugs into a dedicated slot in the Strata CIX40 cabinet. This integrated combination of the Strata CIX40 and GVPH1A is a very powerful and cost-effective small business solution.

The plug and play CIX40 is easy and very cost effective to install. The default plug and play configuration is already programmed in the CIX40 and GVPH1A voice processing system. Any additional programming or changes to the CIX40 can be done by using the latest version of eManager software that is found on Internet FYI.

The CIX40 can be configured with up to 24 IP channels to support Toshiba IP Desktop and Soft phones; SIP telephones, SIP trunks and IP Strata Net channels to network multiple Strata CIX systems.

The CIX40 easily connects to outside public and private telephone lines. All of the telephones (stations) tied to the system can have direct access to each other, as well as to the public and private network. All lines, stations, and options are tied together through the cabinet.

The CIX40 does not require processor licenses for analog Caller ID CO Lines, the first four Voice Mail ports, digital or analog station ports, DTMF Receivers, etc. The only licenses needed are for Voice Mail ports 5~8, IP Strata Net networking channels, Toshiba IP telephones, SIP phones SIP trunks and Soft IP telephones connected to the optional GIPU8, GIPH-X1A, MIPU16-1A and MIPU24-1A IP interface cards.



Licenses are required on the Media Application Server (MAS), Strategy, SES, and customer provided PCs for applications such as ACD, Net Phone, TASKE, Oaisys, FeatureFlex, VCS, Insight, etc.

The CIX40 comes with built-in circuitry for eight digital telephone ports, four CO line ports with Caller ID Interface, one standard telephone port, built-in maintenance modem, LAN/NIC interface, and one power failure transfer relay.

The Strata CIX40 system capacity can be expanded by adding the following expansion components shown in parenthesis:

The fully expanded CIX40 system with optional interface cards provides the following capacities:

- 11 loop start CO line ports with Caller ID and 16 digital station ports (GCDU2A and GCOCIH1A).
- Two standard telephone ports (GSTU1A).
- Eight, 16 or 24 IP channels for IP for any combination of telephone or Strata Net connection (GIPU8, GIPH-X1A, MIPU16-1A or MIPU24-1A).
- 4, 6 or 8 voice mail ports with 40 hours of message storage and 360 mailboxes (GVPH1A, LIC-2 GVPH for 6 or 8 port).
- Four serial interface ports (BSIS).

The table below lists the CIX40 cabinet physical specifications

**Table 1 CIX40 Cabinet Specifications**

Cabinet	Weight	Height	Width	Depth
Cabinet (CHSU40A2) The system cabinet is off-black and contains the GMAU/GMAS motherboards	6.6 lbs.	18 in.	12.2 in.	3.5 in.

## Processor

The Strata CIX40 processor (GCTU2A) is a standard part that plugs into a dedicated CIX40 cabinet slot.

The Strata CIX40 uses a high-speed 32-bit RISC processor, DRAM working memory, SRAM with lithium battery to back-up memory.

The Strata CIX40 processor has the following standard components built-in:

- Secure Digital (SD) memory card interface for program data backup, software upgrades, alarms, error logs, and admin logs done locally or remotely.
- Network Interface Card port provides one circuit for 100base-TX Ethernet LAN connection of the eManager computer, ACD Server, CIX Attendant Console, Multimedia Application Server (MAS) and CSTA applications.
- 33.6 Kbps/V.34 Factory installed AMDS1A maintenance modem for connecting the eManager administration tool locally or remotely.
- One Music-on-hold (MOH)/Background Music (BGM) RCA jack to interface with external MOH and/or BGM sources. The CIX40 can have up to three MOH/BGM source interfaces by adding two additional MOH/BGM input sources, connected to the Standard Telephone interfaces.



- One External Page RCA jack to interface with a Toshiba External Amplified Speaker (BESCB) or a customer-supplied page amplifier and speaker(s) for external paging, night ring over external page, and external BGM applications.
- One Relay control interface that provides an interface to a normally open relay contact which can be programmed to control a Night Bell, door lock or to mute BGM during an external page.
- Memory Protection Battery that protects data and the customers programmed configuration from memory loss. This information will be maintained in a powerless system for at least six years.
- 16 DTMF receivers.
- 16 Busy Tone (BT) detector circuits for Auto Busy Redial (ABR).
- 64 conference circuits.
- Digital volume PAD technology enables audio volume to be adjusted in eight steps to compensate for conference and/or CO line network losses.

The optional Serial Port Interface Subassembly (BSIS1A) can be installed on the processor to provides RS-232 interface ports for SMDR interface to Call Accounting devices, SMDI for external Voice Mail devices, and future applications. The BSIS1A is not needed for the GVPH1A voice mail system because the GVPH1A uses built-in SMDI through the back plane.

## CIX40 Cabinet Slots

The CIX40 Cabinet has three dedicated slots used for the GCTU2A system processor card, GVPH optional Voice Mail circuit card and a slot that can add either four analog lines (GCOCIH1A) or 8, 16 or 24 IP channels (GIPU, GIPH, MIPU16 or MIPU24) optional VoIP interface cards. All other CIX40 optional interface cards plug onto the Processor or the Motherboard. The CIX40 does not support CIX1200/670/200/100 circuit cards.

### Large Scale Integrated (LSI) Circuits (no licenses required)

The processor has an LSI circuit that supports the following:

- 16 DTMF receivers
- 16 Busy Tone (BT) detector circuits for Auto Busy Redial (ABR)
- 64 built-in conference circuits
- Built-in, adjustable, digital volume PAD technology enables audio volume to be adjusted in eight steps to compensate for conference and/or CO line network losses



Figure 1 CIX 40 Interior

## **GCTU2A Processor Interfaces**

### **Memory Protection Battery**

If commercial AC power is lost or if a system is moved or stored without power, the processor has an on-board battery that protects data and the customer's programmed configuration from memory loss. This information will be maintained in a powerless system for at least six years.

### **Relay Control Interface**

An on-board terminal strip provides an interface to a normally open relay contact which can be programmed to control a Night Bell, door lock or to mute BGM during an external page.

### **External Page Interface**

A 600 ohm RCA jack is built into the processor to interface with a Toshiba External Amplified Speaker Control box (BESCB) or a customer-supplied page amplifier and speaker(s) for external paging, night ring over external page, and external BGM applications.

### **Music-on-hold/Background Music Interface**

One 600-ohm RCA jack is provided on the processor to interface with Music-on-hold and/or Background Music (BGM) sources. With the CIX40, you can have up to three MOH/BGM source interfaces. The CIX40 Standard Telephone interfaces can be used to provide up to two MOH/BGM input sources in addition to the processor MOH/BGM interface.

### **Secure Digital Memory**

The processor has an on-board Secure Digital (SD) memory card slot. A SD memory card can be inserted into the slot to backup and restore customer program data. It also makes it easy to upload operating system data for software upgrades and is used to store maintenance log files.

### **CIX40 Processor Optional Subassembly**

Optional subassembly can be attached to the GCTU2A processor to provide additional features. The subassembly is:

BSIS (Serial Port Interface) – Provides up to two RS-232 interface ports for SMDR interface to Call Accounting devices, SMDI for external Voice Mail devices, and two future applications.

#### **Notes**

- The GVPH does not require a BSIS SMDI port.
- The factory installed AMDS maintenance modem and Network Interface Card (NIC) come built into the GCTU2A processor.

## GVPH – Integrated Voice Mail

With the release of Strata CIX40, Toshiba is also introducing a plug and play voice mail circuit card (GVPH1A) specifically for the Strata CIX40 cabinet. It plugs into a dedicated cabinet slot and requires no additional hardware to provide its full set of features.

The CIX40 is pre-programmed to match all related voice mail programming in the GVPH Voice Mail system. This includes station numbers, mailboxes, voice mail hunt groups, voice mail station IDs and many other items which are listed in the CIX40 installation documentation. The pre-programmed data is set when the processor is initialized even if the expansion cards or GVPH1A Voice Mail system is not installed prior to system initialization.

It provides comprehensive Auto Attendant/Voice Mail capabilities, including the following:

- 4-Voice Ports (default) and 6 or 8 ports with LIC-2 GVPH license.
- 40 hours voice storage or up to 10,000 total messages.
- 360 mailboxes.
- Voice Mail Call Monitor – answering machine like operation to monitor and optionally pick-up a call when someone is leaving a voice message.
- Voice Mail LCD Feature Prompting with Soft Key Operation (English and Spanish).
- Call Record – enables the user to record live calls.
- Installs in a dedicated CIX40 cabinet slot with SMDI integration built-in on backplane – no serial port or other interface hardware is needed for interface or for its full set of features.
- Built-in remote maintenance modem.
- Administration requires the GVPH UADMIN2 Administration Software.  
This is a new version of Strategy UADMIN2 exclusively for the GVPH1A.  
It also includes a new software version program update and prompt update capability for remote maintenance.
- The Backup and Restore function stores Names, Greetings, Mail box numbers, and all other database parameters. It does not back up/restore user messages.
- Pre-programmed with default mail boxes that match CIX40 default stations numbers, adding simplicity to any installation.

To program additional features beyond the default settings, refer to *Strata CIX40 Voice Processing Programming Manual* and UADMIN2 software.

## Feature Compatibility

The Strata CIX40 uses the same Release 5.10 software as Strata CIX100, CIX200 and CIX670 systems, so functionality and features are the same between them, with some exceptions that are listed below.

The Strata CIX40 does not support the following capabilities:

- T1 and PRI digital trunk interfaces.
- DID, Ground start and Tie line analog trunk interfaces (supports Loop start with Caller ID).
- Dialed Number Identification Service (DNIS).
- Zone Page Interface.
- Analog Station: Caller ID, message waiting lamp control and off-premise stations

# System Configuration

Following are Strata CIX40 configuration guidelines:

- Pre-programmed to initialize and match CIX40 extension numbers with GVPH1A voice mailboxes. So the system is ready for use when it is powered up the first time.
- Supports all CIX Release 5.2 and above features, except Speaker OCA and OCA on Digital Telephones; T1 and PRI digital trunk interfaces; DID, Ground start and Tie line analog trunk interfaces (supports Loop start with Caller ID), DNIS, and Zone Page Interface.
- Fully Licensed for 18 digital and analog telephones, 4 Voice Mail ports and 11 analog CO lines, 4 RS232 ports and 16-DTMF/ABR circuits. Licensing is only required for Strata Net networking channels, IP telephones, SIP phones, SoftIPs, 6 or 8 voice mail ports, and MAS applications.
- Maximum Capacity is 16 Digital telephones, 11 Loop start lines with Caller ID Interface, 2 Standard telephone interfaces, 8 Voice Mail ports, 24 IP channels, and 4 RS-232 Serial Interface ports.
- Digital Telephone Compatibility – Supports Toshiba DP5000-series telephones, Add-on modules and DSS console. The DP5000-series telephones include a 10 button telephone set (DP5022-SDM) that is designed as a cost-effective telephone for the CIX40.
- IP Telephone Compatibility – Supports all Toshiba 2000-series and 5000-series IP telephones, Add-on-Modules and DSS consoles, SoftIPT soft phones on laptops and PDAs, and SIP telephones.
- CO Line Compatibility – Loop start lines with or without Caller ID.
- Up to 24 IP SIP and Strata Net trunks are supported.

GVPH1A Voice Mail (optional plug in voice mail card):

- 4, 6 or 8 ports, 40 hours storage for saved messages, 360 mailboxes (4 default, 6 or 8 require LIC-2 GVPH).
- Works similar to IVP8R2 with additional features of Voice Mail Call Monitor, Voice Mail LCD Feature Prompting with Soft Key Operation, and Call Record.
- Plugs into CIX40 dedicated cabinet slot.
- SMDI integration built-in on back plane – no serial port or other interface hardware needed.
- Built-in remote maintenance modem.
- Administration requires the GVPH UADM2 Administration Software. This is a new version of Strategy Admin exclusively for the GVPH1A.
- Pre-programmed with default mail boxes that match CIX40 default stations numbers, adding simplicity to any installation.

**Table 2 CIX40 System Configuration**

Basic Configuration - No Licenses Needed	Basic Capacity
CHSU40A2 Cabinet, includes Power supply and Mother Board. The CIX40 cabinet and GCTU2A processor are boxed separately. The cabinet and processor are also warranted and repaired separately.	4 CO line w/CLID, 8 Digital Telephones and 1 Standard Telephone.  Includes: 33.6 Kbps/V.34 Maintenance Modem, Page interface, MOH interface, Control relay, 16 DTMF/ABR circuit, 1 Power Failure Transfer interface, NIC port for 100base-TX Ethernet LAN connection of eManager computer, ACD Server, CIX Attendant Console, and CSTA applications, and a Secure Digital card interface.
Expanded Configuration – No Licenses Needed	Capacity/Feature Option
GCDU2A (3-CO line/8-DKT expansion card)	3 CO line w/CLID and 8 Digital telephones
GCOIH1A (4 - CO expansion card)	4 CO lines with CLID
GVPH1A (voice mail plug-in card)	4-port Toshiba Plug-in Voice Mail system expandable to 6 or 8 ports with LIC-2 GVPH.
GSTU1A (standard telephone plug-on card)	1 Standard Telephone (total 2 standard telephones)
BSIS1A (4-port RS-232 interface plug-on card).	SMDR for Call Accounting or SMDI for external voice mail system
HPFB-6 one to two HPFB6 Battery with built-in Chargers	Reserve Power (Battery Backup)
Expanded Configuration – Licenses Required	Expanded Capacity/Feature Option
GIPU8-1A (8-channel GIPU IP plug-in card) GIPH-X1A (8-channel IP plug-in card). MIPU16-1A (16 channel IP plug-in card). MIPU24-1A (24 channel IP plug-in card). IP License requirements: LIC-CIX-STRN-CH – one license required for each IP Strata Net channel (Strata Net system license is not available). LIC-CIX-IP PORT – one license required for each IP Telephone, SIP phone and SoftIPT. LIC-SOFTIPT – one license required for each SoftIPT.	Maximum 8, 16 or 24 channels for any mix of IP telephones or Strata Net networking channels.

**Note** See the “[CIX40 Functional Block Diagram](#)” on page 12 to see how the circuit cards and interface connectors can be used for connecting stations and peripherals.

**Table 3 CIX40 R2 Cabinet Configurations (CHSU40A2 Cabinet/R5.1 SW)**

Analog CO Lines	Digital Telephones	IP Channels	Equipment
4	8	0	Cabinet (CHSU40A2)
7	16	0	Cabinet, GCDU2A
8	8	0	Cabinet, GCOCIH
11	16	0	Cabinet, GCDU2A, GCOCIH1A
4	8	8, 16, 24	Cabinet, GIPU, GIPH1A, MIPU161A, MIPU241A
7	16	8, 16, 24	Cabinet, GCDU2A, GIPU, GIPH1A, MIPU16, MIPU24
Voice Mail: GVPH1A can be installed in all of the above configurations to provide 4 default VM Ports and expand to 6 or 8 VM Ports with the LIC2-GVPH license			
Analog FX/Modem Ports: One analog station port is standard on the Base cabinet; a second can be added by installing GSTU1A.			

**Table 4 CIX40 R1 Cabinet Configurations (CHSU40A Cabinet/R5.1 SW)**

Analog CO Lines	Digital Telephones	IP Channels	Equipment
3	8	0	Cabinet (CHSU40A)
6	16	0	Cabinet, GCDU2A
7	8	0	Cabinet, GCOCIH
10	16	0	Cabinet, GCDU2A, GCOCIH1A
3	8	8, 16	Cabinet, GIPU8, GIPH1A, MIPU16
6	16	8, 16	Cabinet, GCDU2A, GIPU8, GIPH1A, MIPU16
Voice Mail: GVPH1A can be installed in all of the above configurations to provide 4 default VM Ports and expand to 6 or 8 VM Ports with the LIC2-GVPH license			
Analog FX/Modem Ports: One analog station port is standard on the Base cabinet; a second can be added by installing GSTU1A.			

## Reserve Power

One or two HPFB-6 optional units can be added to the CIX40 to provide reserve power. The amount of reserve power time depends on the hardware (see [Table 5](#)). The table below is an estimate of battery backup time based on the premise that the HPFB-6 unit(s) are fully charged at the time of AC power failure. This estimated backup time is based on normal call traffic, the time estimates will be reduced by as much as half with extreme heavy traffic volumes.

**Table 5 CIX40 Reserve Power Duration Estimates**

Hardware	1 HPFB-6	2 HPFB-6
3CO/8DKT/DP - No GVPH	1 hr. 40 min.	3 hr. 20 min.
3CO/8DKT/DP - with GVPH	1 hr. 30 min.	3 hr.
6CO/16DKT/DP - No GVPH	1 hr. 5 min.	2 hr. 10 min.
6CO/16DKT/DP - with GVPH	1 hr.	2 hr.
11CO/8DKT/DP - No GVPH	1 hr. 20 min.	2 hr. 40 min.
11CO/8DKT/DP - with GVPH	1 hr. 10 min.	2 hr. 20 min.
11CO/16DKT/DP - No GVPH	1 hr.	2 hr.
11CO/16DKT/DP - with GVPH	55 min.	1 hr. 50 min.

**Note** The CIX40 should be plugged into AC power and the DC power switch should be turned on when installing the HPFB-6. The HPFB-6 will not start to operate if AC power is not available during the initial installation.

## Telephone and Console Support

The Strata CIX40 supports all current Toshiba 5000-series Telephones, Add-on Module, DSS Console, and CIX Attendant Console. see [Chapter 7 – Telephones and Peripherals](#).

The Strata CIX40 supports 3000-series and 3200-series digital telephones, including the DKT3007-SD(W) and DKT3207-SD 7-button models, Add-on Module, DSS Console, CIX Attendant Console, and generic single-line telephones (2500-sets). For details on Telephones and Consoles, see [Chapter 7 – Telephones and Peripherals](#).

The Strata CIX40 supports Toshiba 2000-series and 5000-series IP telephones, SoftIPT soft phones on laptops and PDAs, and SIP telephones.

The Strata CIX40 does not support analog electronic telephones (6500-series, 6000-series, etc.) or older IPT1020-SD IP telephones.

The Strata CIX40 supports CIX IP and Digital Attendant consoles.





# Additional Specifications

**Table 6 CIX40 Specifications**

Category	Items	Specification	Remarks
Power	Input voltage rating	100-240VAC	
	Input current rating	1.3A max.	At full installation
	Input frequency	50/60 Hz	
	AC adapter output voltage	+15V/4.0A	
	Voltage of inside Power switch	-27.3V/+5.0V	
		DC Switch	Located inside cabinet
	Power failure back up	1 HPFB6: 1 hour 2 HPFB6: 2 hours See <a href="#">page 11</a>	The amount of time depends on hardware configuration. One hour in HPFB6 means 6 CO+16DP with GVPH based on HPFB6 is fully charged.
	Grounding	Customer supplied Grounding wire.	Ground wire must connect the earth ground through the FG terminal on the GMAU for safety purposes and to protect noise.
AC Plug	2-pin (American)	Ground wire must connect the earth ground through the FG terminal on the GMAU for safety purposes and to protect noise.	
Environment	Operating Temperature	0 - 40 C	
	Operating humidity	20 - 80%	
	Storage temperature	-20 - 60 C	
Safety System	Maximum ports	40	16: DP phones
			6: Analog trunk
			8: IP channel
			4: Voicemail
			2: Analog devices
Regulation	Safety	UL60950-1	USA
	EMC	FCC part15 class-A	
	Network Performance	FCC part68	
FCC/ACTA Registration Numbers	ACTA/FCC Part 68 Registration for Key System Code (KD): CJ6KD03BDTCHS402		
	ACTA/FCC Part 68 Registration for Multifunction Code (MF): CJ6MF03BDTCHS402		
	ACTA/FCC Part 68 Registration for Multifunction Code (PF): CJ6PF03BDTCHS402		

## Station Loop Limits

The table below provides the maximum loop limits for connection of telephones, lines, peripheral equipment, and power supplies. The following information applies to only the Strata CIX40 system.

Digital Telephone/DIU/DDM Console/ADM/Loop Limits

Mode	CIX40 Cabinet or Battery Backup <sup>1</sup>	Maximum line length (24 AWG)	
		1 Pair feet	1 Pair meters
DP5000, DKT3000, DKT3200-series or DKT2000-series models, DP with BVSU <sup>2</sup> or DVSU or BHEU or HHEU.	CIX40 Cabinet	1000	303
	Battery Backup	695	204
DKT with BPCI	CIX40 Cabinet	1000	303
	Battery Backup	500	151
DKT with BPCI and BHEU	CIX40 Cabinet	1000	303
	Battery Backup	500	151
DSS3060 or DSS2060	CIX40 Cabinet	1000	303
	Battery Backup	675	204
DDCB3A	CIX40 Cabinet	165	50
	Battery Backup	500	151
BATI, RATI	CIX40 Cabinet	1000	303
	Battery Backup	1000	303
DKT with 1 ADM	CIX40 Cabinet	675	204
	Battery Backup	165	50
DKT with 2 ADMs	CIX40 Cabinet	500	151
	Battery Backup	33	10

1. Battery backup applies to instances when the system is being powered by batteries exclusively.
2. CIX40 Digital Telephones do not support Speaker OCA.

This chapter provides a system overview of the Strata CIX100-S and CIX100 telephone systems.

The Strata CIX100-S/CIX100 systems are compact systems, yet they provide large system features (see [Figure 3](#) and [Table 7](#)). They are designed for wall mounting and occupy very little space.

The CIX100 processor (ACTU3A) comes with 32 ports (licensed) and can grow to 112 ports by adding 4-port licenses.

The CIX100-S processor (ACTU3A-S) comes with 16 ports (licensed) and can grow to 32 ports by adding two eight-port licenses. Then, it can grow to 112 ports with four-port licenses.

**Note** The Strata CIX100-S and CIX100 system capacities depend on the licenses stored on the system processor and the hardware described in this chapter.

**Important!** *The Strata CIX100-S uses the same hardware and configuration as the Strata CIX100 with a few exceptions. Whenever the CIX100 is mentioned in this book, it applies to both the CIX100-S and CIX100 unless specified otherwise.*

Each ACTU3 basic processor can be configured with a one or two cabinet system. A single (Base) cabinet system supports a combination of up to 64 Central Office (CO) lines and stations, while a two cabinet system (Base and Expansion) can support up to 112 CO lines and stations.

System line and station capacity is expanded by adding CO line and station circuit cards and port licenses into its universal slot architecture.

The CIX100 easily connects to outside public and private telephone lines. All of the telephones (stations) tied to the system can have direct access to each other, as well as to the public and private network. All lines, stations, and options are tied together through the cabinets.

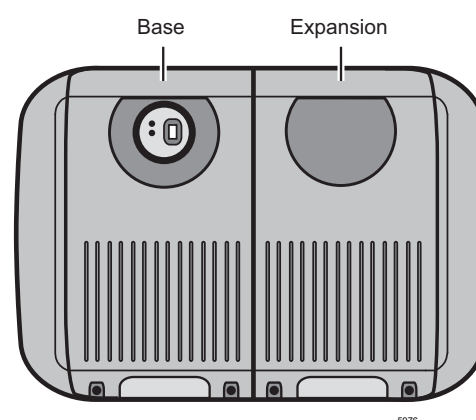

**Figure 3 CIX100-S / CIX100 Base / Expansion Cabinets**

**Table 7 CIX100-S/CIX100 Cabinet Specifications**

Cabinet	Weight <sup>1</sup>	Height	Width	Depth
Base Cabinet (CHSUB112)	19.4 lbs.	14.6 in.	11.9 in.	10.2 in.
Base + Expansion Cabinet (CHSUE112)	34.6 lbs.	14.6 in.	19.9 in.	10.2 in.

1. Weight includes the processor card in the Base Cabinet and four universal circuit cards in each cabinet.

# CIX100-S and CIX100 Processors

Each system operates with one processor card (ACTU3A-S for CIX100-S, ACTU3A for CIX100) that installs in a dedicated slot of the Base Cabinet. The processors incorporate the following hardware features.

## CPU/Memory

Either processor card uses a high-speed, 32-bit, RISC processor, Dynamic Random Access Memory (DRAM) working memory, Static Random Access Memory (SRAM) with lithium battery for memory back-up, and flash program memory.

## Large Scale Integrated (LSI) Circuits

The processors each have LSI circuits that support the following:

- 16 DTMF receiver hardware processor are built into the ACTU3. Five or more DTMF receivers require appropriate licenses.
- 16 Busy Tone (BT) detector circuits for Auto Busy Redial (ABR) are built into the ACTU3.
- 64 built-in conference circuits.
- Built-in, adjustable, digital, volume PAD technology enables audio volume to be adjusted in eight steps to compensate for conference and/or CO line network losses.

## Memory Protection Battery

If commercial AC power is lost or if a system is moved or stored without power, the processor has an on-board battery that protects data and the customer's programmed configuration from memory loss. This information will be maintained in a powerless system for at least six years.

## Relay Control Interface

An on-board terminal strip provides an interface to a normally open relay contact which can be programmed to control a Night Bell or door lock or to mute BGM during an external page.

## External Page Interface

A 600 ohm RCA jack is built into each processor to interface with a Toshiba External Amplified Speaker (BESCB) or a customer-supplied page amplifier and speaker(s) for external paging, night ring over external page, and external BGM applications.

## Music-on-hold/Background Music Interface

A 600-ohm RCA jack and volume controls are built into each processor to interface with Music-on-hold and/or Background Music (BGM) sources (one of the jacks is for future use). With the CIX100, you can have up to 15 MOH/BGM source interfaces by adding:

- Up to two BIOU circuit cards, each provides three MOH/BGM input sources
- An RSTU circuit card that provides up to eight MOH/BGM input sources

## Secure Digital Memory

Each processor has an on-board SD memory card slot. A SD flash memory card can be inserted into the slot to backup and restore customer program data. It also makes it easy to upload operating system data for software upgrades and is used for maintenance functions (see [“System Fault Finding and Diagnostics” on page 143](#) for more details).

## Built-in Ethernet Connection

The ACTU processor has an on-board Ethernet 100Base-T Ethernet interface for connection to Open Architecture Computer Telephony Interface (CTI) applications. This provides extensive call control and telephone support for CTI applications. The Ethernet Network Interface Card (NIC) port also enables connection to the following:

- CIX Attendant Console
- ACD server
- Local and Remote eManager PC
- Soft Key Control of Voice Mail features

## CIX100 Processor Optional Subassemblies

Optional subassemblies can be attached to the ACTU3A-S or ACTU3A processors to provide additional features. The subassemblies are:

- **AMDS (Modem)** – Provides a 33.6Kbps/V.34 modem for point-to-point local or remote connection to the eManager administration PC.
- **BSIS (Serial Port Interface)** – Provides up to two RS-232 interface ports for SMDR interface to Call Accounting devices, SMDI or Toshiba Proprietary interface to Voice Mail devices, and two future applications.

## CIX100 Cabinet Slots

### Base Cabinet

The Base Cabinet has one dedicated slot used for the system processor card and four universal slots (S101~S104), that can accommodate station, line or option circuit cards. It also houses a power supply that is packaged with the cabinet.

### Expansion Cabinets

One expansion cabinet has four universal circuit card slots (S105~S108) that can accommodate station, line or option circuit cards. It also houses a power supply that is packaged with the cabinet.

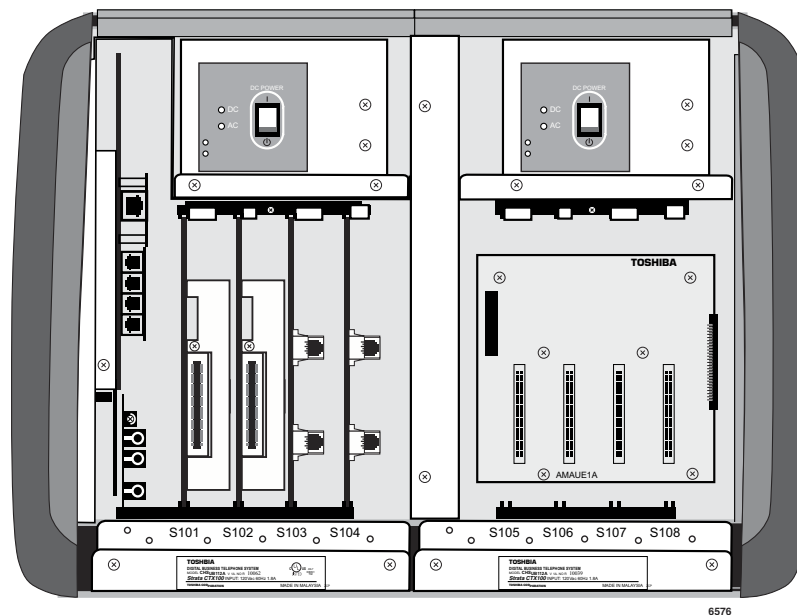

Figure 4 Base and Expansion Cabinet Interior

This page is intentionally left blank.

The Strata CIX200 supports 192 ports and can be configured as a one or two cabinet system, consisting of a Base Cabinet and one optional Expansion Cabinet. One processor model supports all Strata CIX200 configurations from smallest to largest.

These cabinets are designed specifically to fit standard (customer-supplied) 19" racks. The 19" rack and rack screws must be supplied by the dealer. Interface cables connect directly to the front panel or exit the cabinet through a port on the right side of the cabinet.

The CIX200 uses a single-card common control processor unit (LCTU2A), with a high-speed 32-bit RISC processor, 64 MB DRAM working memory, SRAM with lithium battery on-board flash program memory, and removable Toshiba Secure Digital flash memory.



## Base Cabinet

The Base Cabinet (CHSUB192A) has four slots. The upper left slot, labeled B101 is reserved for the common control unit. The other three slots (labeled S101, S102 and S103) are universal card slots capable of hosting any of the station, line, and option interface PCBs compatible with the Strata CIX systems. The Base Cabinet also has a dedicated LSLU slot located at the back of the cabinet for two analog ports with two connectors on the front of the cabinet.

## Expansion Cabinets

One Expansion Cabinet (CHSUE192A) can be added to increase the system station and CO line capacity. The Expansion Cabinet has four universal slots for interface cards (labeled S201 ~ S204). Compatible interface cards include the MIPU / LIPU / LIPS IP interface cards and the current Strata CIX interface cards that support CO lines, digital telephones, analog stations, etc.

Refer to [“Capacities” on page 177](#) for cabinet slot and station/line capacities.

## Basic Specifications

The following table lists the parts and basic specifications of the CIX200 Rack Mount Cabinets.

Dimensions of each cabinet – Base (CHSUB192A) and Expansion (CHSUE192A)	Height: 3.5 inches (88.9 mm) Width: 17.3 inches (440mm – without bracket); 19 inches (483 mm – with bracket) Depth: 16.1 inches (410mm) Weight: 16 lbs (7.2 kilograms)
Power Supply Unit (PSU)	Initially Built-in
19" Rack Installation Dimension	IEC297-1 (EIA RS 310-D) 465.1mm (front face screw pitch – width)
Installation	Rack-mount (preferred) or Table top. <b>Important!</b> <i>Do not place the equipment on the floor or in a dusty place.</i>

## Power Backup

An Uninterruptible Power Supply (UPS) is required for power backup on a CIX200. The UPS is similar to the ones used for computer systems and networking equipment.



# Configuration

The two primary considerations in system configuration are Card Slot Use and Power Factor.

## Card Slot Use

The card slots can each support up to 32 ports. There are a few card position requirements based on cable lengths. These are discussed in detail in the *Strata CIX Installation Manual*. These requirements do not affect the system capacities.

In general, determine the number and type of stations needed, the number and type of trunks, and any additional requirements. Other requirements include voice mail, power fail transfer, tie lines, etc. The total number of ports required must not exceed 192.



Figure 5 Two Cabinet CIX

## Power Factor

Power Factors for the CIX200 circuit cards are shown below. For all others please refer to the Installation and Maintenance Manual.

- LCTU1A: No effect on Power Factor calculations
- MIPU: PF = 0.2
- LIPU-X1A: PF = 2.6
- LIPS-X1A: PF = 1.9
- LSLU1A: PF = 1.5

There are no Power Factor considerations for the new IP Telephones (IPT2010/2020/2008), add-on modules (IADM2020 and IDSS2060), and DSS consoles because the power is not supplied from CIX200 cabinet.

The system (-24V) Power Factor is 67 per cabinet. There is no +5V power factor consideration for the CIX200. For an example on how to use the System Power Factor and for worksheets, refer to the *Strata CIX Installation and Maintenance* manual.

## CIX200 PCBs

Two circuit cards are specific to the CIX200 systems; the LCTU processor card and the LSLU, a two-circuit, single-line, telephone interface card. The MIPU24 IP interface card with 24 channel works with the CIX200. The LIPU, an IP interface with 16 resources expands to 32 with the LIPS expansion card and works on all CIX systems.

### PCB Option Considerations

Strata CIX PCBs can be configured for a variety of hardware and software options. Hardware options are defined as either internal (generally related to optional PCB subassemblies) or external (related to connection of peripheral equipment such as background music, voice mail, etc.).

Some PCBs must have hardware options, such as jumpers or switches, set prior to installation of the PCB in the cabinet.

### Common Control Processor Unit (LCTU)

The system operates with the LCTU2A processor PCB that installs in a dedicated slot of the Base Cabinet. The Strata CIX200 processor has the following standard components built in:

- Secure Digital (SD) memory card interface. A SD flash memory card can be inserted to backup and restore customer program data. It also makes it easy to upload operating system data for software upgrades and maintenance functions.

**Note** LCTU1A uses Smart Media (SM) flash memory.

- One Music-on-hold/Background Music Interface is provided by an RCA jack and a volume control that are built into the processor to interface with a Music-on-hold and/or Background Music source. Up to 15 MOH/BGM sources are supported by adding up to two BIOU option cards, each provides three MOH/BGM input sources, and a BSTU card that provides up to eight MOH/BGM input sources. MOH/BGM source volume adjustment is controlled by software programming.
- Network Interface Card (NIC) Ethernet 100Base-T Ethernet port for IP management and connection to Open Architecture Computer Telephony Interface (CSTA) applications. This provides extensive call control and telephone support for CTI applications.
- 16 built-in DTMF receivers (five or more DTMF receivers require licenses).
- 16 built-in Busy Tone (BT) detectors for Auto Busy Redial (ABR).
- 64 built-in conference circuits.
- Built-in, adjustable, digital volume PAD technology enables audio volume to be adjusted in eight steps to compensate for conference and/or CO line network losses.
- Page connector – External Page interface.
- Relay connector – Relay Control interface.
- Memory Protection Lithium Battery that protects data and the customer's programmed configuration from memory loss. This information will be maintained in a powerless system for at least six years.

Optional subassemblies can be added to the LCTU processor PCB to enable system expansion and provide additional features. The subassemblies are:

BSIS interface PCB attaches to the LCTU to provide up to four RS-232 interface ports for SMDR Call Accounting, and SMDI or Toshiba Proprietary Voice Mail interface.

AMDS (Modem) – Provides a 33.6Kbps/V.34 modem for point-to-point local or remote connection to the eManager administration PC.

## Analog Standard Station Interface Unit (LSLU1A)

The optional 2-circuit LSLU card provides for connection of two analog devices, such as faxes, modems, standard telephones, etc., without message waiting. The LSLU installs into a dedicated mount in rear of Strata CIX Base Cabinet behind the processor slot. The LSLU does not occupy any of the universal slots of the cabinet, so it does not reduce the maximum capacity of the system. The two analog station ports are accessible on the front of the base cabinet via modular connectors.

## Modular or Amphenol Connections

The Strata CIX200 provides a choice of using either RJ45 modular connectors or amphenol connectors for terminating CO line and station interfaces.

- Modular connectors provide an IT friendly environment using RJ45 cables and patch panel connections in data racks.
- Amphenol connectors provide efficient connection to existing voice cables terminated on the wall on 110 or 66 blocks.
- Either way, the installation technician can exercise his preference or the customer's preference for the type of connection that will take less time to install or save the customer money.

Modular RJ45 connectors are provided by adding optional extenders and modular faceplates to CIX interface cards used in the Strata CIX200. This enables the modular interface cables to be connected at the front panel of the CIX200 cabinet.

Amphenol connectors are provided by using CIX interface cards in the Strata CIX200 without extender cards. In this configuration, amphenol interface cables are routed through the side of the cabinet and a flat face plate covers the slot housing the card. See the *Strata CIX Installation and Maintenance Manual* for more details on Modular or Amphenol connections.

The Strata CIX200 supports two different types of optional extenders for the other CIX interface cards, depending upon the type of connectors that exist on the card.

### Extenders

The CIX system uses two types of extenders. One type is connected between the interface card and the cabinet backplane. This type of extender brings the interface connectors to the front of the cabinet. The correct front plate for the interface card is packaged with the extender. These extenders are optional.

The second type of extender plugs into the interface card front connector and presents different connectors to the front plate. Some of this type are optional, such as the extender that connects to the 25-pair Amphenol connector on the station card and presents eight or 16 modular connectors to the front panel. Refer to [Table 8](#).

### Power Failure Transfer Unit (LPFU1A)

The optional 8-circuit LPFU card when used with the RCOU and RSTU cards can automatically connect the CO line circuits to the Single Line Telephones (SLT) when system power fails. The LPFU card installs onto the CO line card as an extender, so it shares the same cabinet slot. The RCOU card must be in the slot above.

**LCNU-A1A, LCNU-B1A, LCNU-C1A, LCNU-D1A, LEXU, and LCNU-E1A**

**Table 8 CIX Extender Use**

Extender	Used For	Required	Comments
LEXU-A1A	LIPU/MIPU	Optional	Extender installed between card and chassis backplane. Interface card connectors are brought to the cabinet face.
LEXU-B1A	BPTU1A RDTU3A	Optional	
LEXU-C1A	IVP8	Optional	
LCNU-A1A	BSTCIU1A	Optional	Plugs into the 50-pin Amphenol socket on the interface card. Extends modular connectors to the CIX200 chassis face.
LCNU-B1A	BWDKU1A BDKU/ BDKS	Optional	
LCNU-C1A	RCOU3A RGLU3A RDDU2A BCOCIU1A	Optional (See Comments)	Plugs into the modular connectors on the interface card. Extends modular connectors to the CIX200 chassis face. The LCNU-C1A connects the CO lines and Caller ID in one connector. If not used the connections must be made on the MDF.
LCNU-D1A	REMU1A	Optional	Plugs into the modular connectors on the interface card. Extends modular connectors to the CIX200 chassis face.
LCNU-E1A	RCIU2A	Required (See Comments)	The LCNU-E1A is a set of small cables. These are required only if the LCNU-C1A is used. Connects RCIU2A to the LCNU-C1A to connect the Caller ID and CO line together in one modular socket.
LPFU1A	Power Fail Transfer	Required	Required for power fail transfer operation. The LPFU1A is two extender cards and two cables. The CO and Station cards must be in adjacent slots.

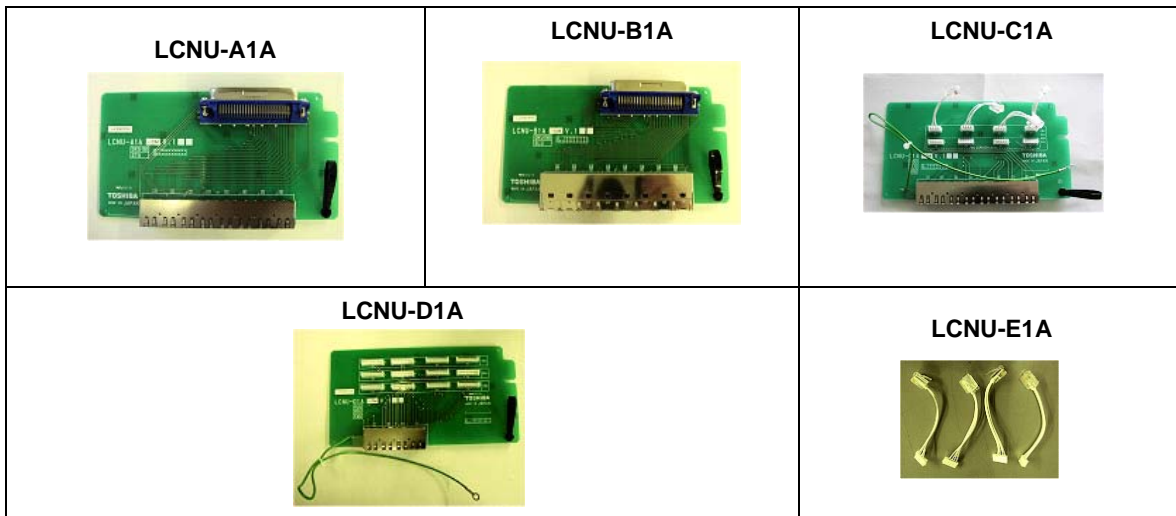

## Strata CIX670

The Strata CIX670 system provides sophisticated telecommunication features in a modular system designed for growth. Its universal slot architecture enables you to select the combination of Central Office (CO) lines, stations, and peripheral options that best suit your needs.

The CIX670 BCTU basic processor can be configured for smaller systems as a one or two cabinet system with a capacity of up to 192 CO lines and stations combined. It can expand to support up to seven cabinets with a capacity of up to 672 CO lines and stations combined with the BCTU/BEXU expanded processor (see [Figure 6](#)).

System line and station capacity is expanded by adding processor expansion Circuit Cards, cabinets and line/station circuit cards and station/line licenses.

The CIX670 easily connects to outside public and private telephone lines. All of the telephones (stations) tied to the system can have direct access to each other as well as to the public and private network.

The Base Cabinet and optional Expansion Cabinets are the building blocks of the system. Each system has a Base Cabinet, and can have from one to six Expansion Cabinets. All lines, stations, and options are tied together through the cabinets. There are two types of cabinets, floor/wall mountable and rack mountable. See [page 32](#) for details on rack mountable cabinets.

The overall weight and dimensions of the CIX670 cabinets are shown in [Table 9](#).



**Figure 6** CIX 670 Base/Expansion Cabinets

**Table 9** CIX670 Floor/Wall Mount Cabinet Specifications

Cabinet	Weight	Height	Width	Depth
Base Cabinet (CHSUB672)	31 lbs.	11.625 in.	26.5 in.	10.3 in.
Expansion Cabinet (CHSUE672)	29 lbs.	9.75 in.	26.5 in.	10.3 in.

## CIX670 Processor Circuit Cards

The system operates with the BCTU only or the BCTU and BEXU processor circuit cards that install in dedicated slots of the Base Cabinet. The BCTU and BEXU processor incorporates the following on-board hardware features:

### CPU/Memory

The CIX670 uses a high-speed, 32-bit, Reduced Instruction Set Computing (RISC) processor, Dynamic Random Access Memory (DRAM) working memory, Static Random Access Memory (SRAM) with lithium battery for back-up memory and flash program memory.

### Large-scale Integrated (LSI) circuits

The processor has LSI circuits that support the following:

- BCTU provides 16 built-in DTMF receivers; 32 available using the BCTU and BEXU. For five or more DTMF receivers, appropriate licenses are required.
- BCTU provides 16 built-in Busy Tone (BT) detectors for Auto Busy Redial (ABR); 32 available using the BCTU and BEXU.
- BCTU provides 64 built-in conference circuits; up to 96 conference circuits are available using the BCTU and BEXU.
- Built-in, adjustable, digital volume PAD technology enables audio volume to be adjusted in eight steps to compensate for conference and/or CO line network losses.

### Memory Protection Battery

If commercial AC power is lost or if a system is moved or stored without power, the processor has an internal battery that protects data and the customer's programmed configuration from memory loss. This information will be maintained in a powerless system for at least six years.

### Music-on-hold/Background Music Interface

An RCA jack and volume control are built into the processor to interface with a Music-on-hold and/or Background Music source. With the CIX670, you can have up to 15 MOH/BGM sources by adding:

- Up to two BIOU circuit cards, each provides three MOH/BGM input sources.
- A BSTU or any analog station card that provides up to eight MOH/BGM input sources.
- MOH/BGM source volume adjustment is controlled by software programming.

### Secure Digital (SD) Memory

The BCTU processor has an on-board Secure Digital card slot. A SD flash memory card can be inserted to backup and restore customer program data. It also makes it easy to upload operating system data for software upgrades and is used for maintenance functions (see [“System Fault Finding and Diagnostics” on page 143](#) for more details).

## Network Interface

The BCTU processor has an on-board Ethernet 100Base-T Ethernet interface for connection to Open Architecture Computer Telephony Interface (CTI) applications. This provides extensive call control and telephone support for CTI applications. The Ethernet Network Interface Card (NIC) port also enables connection to the following:

- CIX Attendant Console
- ACD server
- Local and Remote eManager PC
- Soft Key Control of Voice Mail features
- Media Application Server (MAS)

## CIX670 Processor Optional Subassemblies

Optional subassemblies can be added to the BCTU processor card to enable system expansion and provide additional features. The subassemblies are:

- AMDS (Modem) – Attaches to the BCTU to provide a 33.6Kbps/V.34 modem for point-to-point local or remote connection to the eManager administration PC.
- BSIS interface card which attaches to the BCTU to provide up to four RS-232 interface ports for SMDR Call Accounting and SMDI or Toshiba Proprietary Voice Mail interface.

# Strata CIX1200

The Strata CIX1200 system provides sophisticated telecommunication features in a modular system designed for growth. Its universal slot architecture enables you to select the combination of Central Office (CO) lines, stations, and peripheral options that best suit your needs.

The CIX1200 HCTU basic processor can be configured for smaller systems as a one or two cabinet system with a capacity of up to 192 CO lines and stations combined. It can expand to support up to seven cabinets with a capacity of up to 672 CO lines and stations combined with the HCTU/HEXAU expanded processor. This configuration provides the same number of ports as the CIX670. However, it provides expanded feature capacity for items such as LCR tables, Network routing tables, etc.

The Strata CIX1200 can expand to support twelve cabinets (shown right) with a capacity of up to 1,152 CO lines and stations combined with the HCTU/HEXBU expanded processors.

System line and station capacity is expanded by adding processor expansion circuit cards, cabinets and line/station circuit cards and station/line licenses.

The CIX1200 easily connects to outside public and private telephone lines. All of the telephones (stations) tied to the system can have direct access to each other as well as to the public and private network.

The Base Cabinet and optional Expansion Cabinets are the building blocks of the system. Each system has a Base Cabinet, and can have from one to 11 Expansion Cabinets. All lines, stations, and options are tied together through the cabinets. There are two types of cabinets, floor/wall mountable and rack mountable. See [page 32](#) for details on rack mountable cabinets.

The overall weight and dimensions of the CIX1200 cabinets are shown in [Table 10](#).

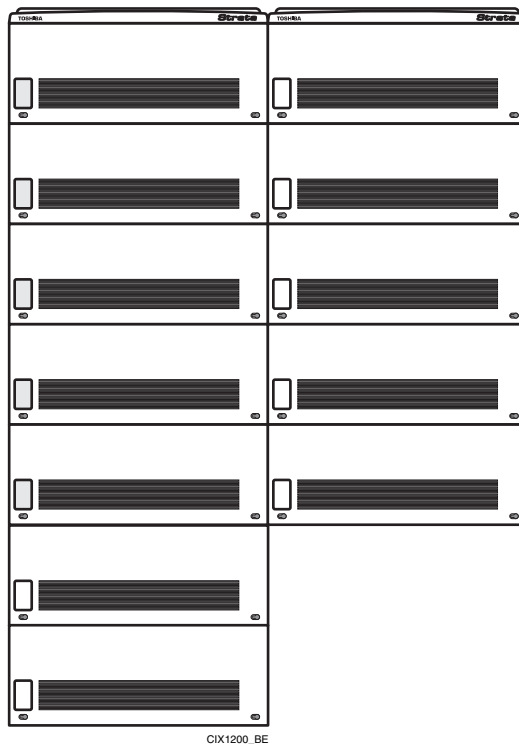

**CIX 1200 Base/Expansion Cabinets**

**Table 10 CIX1200 Floor/Wall Mount Cabinet Specifications**

Cabinet	Weight	Height	Width	Depth
Base Cabinet (CHSUB672)	31 lbs.	11.625 in.	26.5 in.	10.3 in.
Expansion Cabinet (CHSUE672)	29 lbs.	9.75 in.	26.5 in.	10.3 in.



# CIX1200 Processor Circuit Cards

The system operates with the HCTU (2 cabinets) only or the HCTU and HEXAU (7 cabinets) or HCTU and HEXBU (12 cabinets) processor circuit cards that install in dedicated slots of the Base Cabinet. The processor cards incorporate the following on-board hardware features:

## CPU/Memory

The CIX1200 uses a high-speed, 32-bit, Reduced Instruction Set Computing (RISC) processor, Dynamic Random Access Memory (DRAM) working memory, Static Random Access Memory (SRAM) with lithium battery for back-up memory and flash program memory.

## Large-scale Integrated (LSI) circuits

The processor has LSI circuits that support the following:

- HCTU provides 16 built-in DTMF receivers; 32 available using the HCTU and HEXAU and 48 using the HCTU and HEXBU. For five or more DTMF receivers, appropriate licenses are required.
- HCTU provides 16 built-in Busy Tone (BT) detectors for Auto Busy Redial (ABR); 32 available using the HCTU and BEXAU and 48 using HCTU and HEXBU.
- HCTU provides 64 built-in conference circuits; up to 96 conference circuits are available using the HCTU and HEXAU and up to 128 conference circuits using HCTU and HEXBU.
- Built-in, adjustable, digital volume PAD technology enables audio volume to be adjusted in eight steps to compensate for conference and/or CO line network losses.

## Memory Protection Battery

If commercial AC power is lost or if a system is moved or stored without power, the processor has an internal battery that protects data and the customer's programmed configuration from memory loss. This information will be maintained in a powerless system for at least six years.

## Music-on-hold/Background Music Interface

An RCA jack and volume control are built into the processor to interface with a Music-on-hold and/or Background Music source. With the CIX1200, you can have up to 15 MOH/BGM sources by adding:

- Up to two BIOU circuit cards, each provides three MOH/BGM input sources.
- A BSTU or any analog station card that provides up to eight MOH/BGM input sources.
- MOH/BGM source volume adjustment is controlled by software programming.

## Secure Digital (SD) Memory

The HCTU processor has an on-board Secure Digital card slot. A SD flash memory card can be inserted to backup and restore customer program data. It also makes it easy to upload operating system data for software upgrades and is used for maintenance functions (see [“System Fault Finding and Diagnostics” on page 143](#) for more details).

## **Network Interface**

The HCTU processor has an on-board Ethernet 100Base-T Ethernet interface for connection to Open Architecture Computer Telephony Interface (CTI) applications. This provides extensive call control and telephone support for CTI applications. The Ethernet Network Interface Card (NIC) port also enables connection to the following:

- CIX Attendant Console
- ACD server
- Local and Remote eManager PC
- Soft Key Control of Voice Mail features
- Media Application Server (MAS)

## **CIX1200 Processor Optional Subassemblies**

Optional subassemblies can be added to the HCTU processor card to enable system expansion and provide additional features. The subassemblies are:

- AMDS (Modem) – Attaches to the HCTU to provide a 33.6Kbps/V.34 modem for point-to-point local or remote connection to the eManager administration PC.
- BSIS interface card which attaches to the HCTU to provide up to four RS-232 interface ports for SMDR Call Accounting and SMDI or Toshiba Proprietary Voice Mail interface.

# CIX670 and CIX1200 Cabinet Slots

## Base Cabinet

The Base Cabinet has two dedicated slots used for the system processor cards and eight universal slots, labeled “S101~S108,” that can accommodate station, CO line or option circuit cards (see [Figure 7](#)). It also houses a power supply.

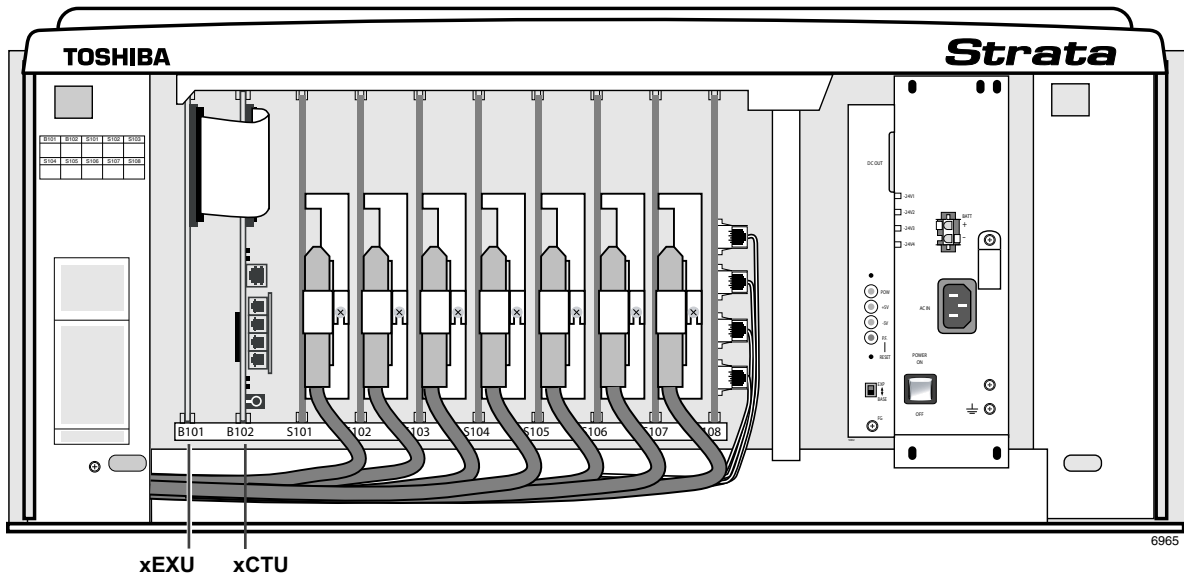

Figure 7 Base Cabinet Interior

## Expansion Cabinets

One to twelve Expansion Cabinets can be added to increase the system station and CO line capacity. Each expansion cabinet provides 10 slots (S\_01~S\_10). [Figure 8](#) shows an Expansion Cabinet.

Refer to the following section for cabinet slot and station/line capacities. [Table 50](#) and [51](#) show the number of stations and CO lines allowed when additional cabinets and circuit cards are used.

**Note** CIX1200 expansion cabinets 8 through 12 must be connected with fiber optic cables (see [page 34](#)).

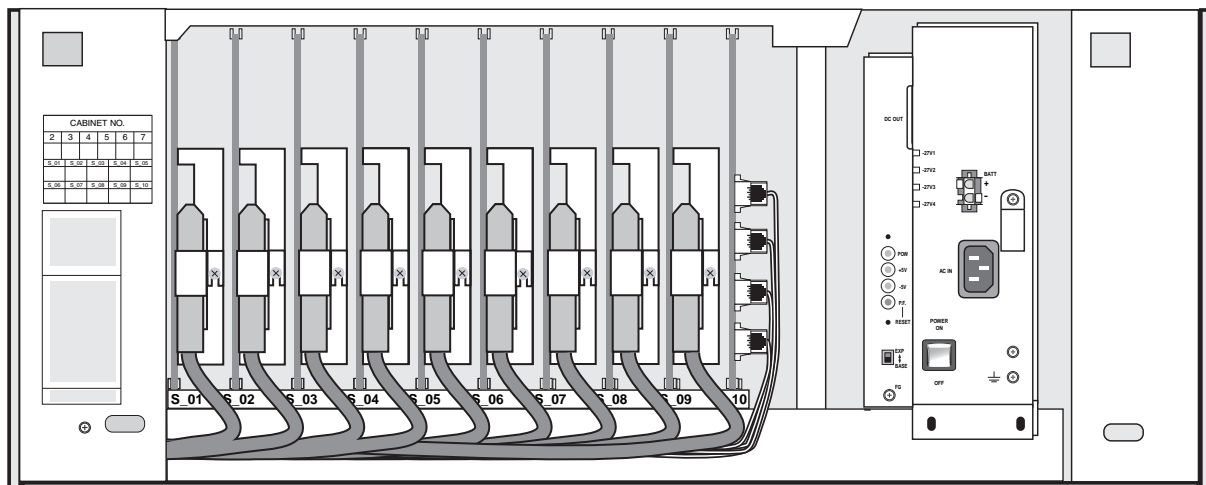

Figure 8 Expansion Cabinet Interior

# Strata CIX670 and CIX1200 Rack Mount

The Strata CIX670 and CIX1200 Rack Mount cabinets consist of a Base cabinet (CRSUB672A) and Expansion cabinets (CRSUE672A). These cabinets are deeper, narrower, and designed specifically to fit standard (customer-supplied) 19” racks (shown right). The cabinets are made of plated sheet metal, dark gray in color with black cover plates. These cabinets support the same features as the floor/wall-mountable CIX670 and CIX1200 cabinets.

A CIX670 system can expand from one to seven cabinets using the same processors and interface cards as the CIX670 floor/wall-mountable cabinets. The CIX1200 system can expand from one to twelve cabinets using the same processors and interface cards as the CIX1200 floor/wall-mountable cabinets. The power factors and slot configuration rules are also the same as the floor/wall-mountable cabinets.

The difference between the floor/wall mount and the rack mount cabinets is the size for the Base and Expansion cabinets, the power supply that is installed in the cabinets, and a unique power strip for rack mount cabinets (BRPSB120A and the 240V version).

Toshiba does not support mixing the floor/wall-mountable cabinets with the rack mountable cabinets. The 19 inch-wide rack and rack screws must be supplied by the dealer. Interface cables plug into the front of the station and trunk cards and fold under each cabinet to exit the rear of the cabinets.



## Basic Specifications

The following table lists the parts and basic specifications of the CIX1200 Rack Mount Cabinets.

Dimensions of Base (CRSUB672A) and Expansion (CRSUE672A) Cabinet	Height: 10.5 inches (267mm) Width: 1.58 feet (483mm—with bracket) Depth: 1.17 feet (358mm)	
Weight of Base and Expansion Cabinet	22.04 lbs. (10 kg)	
Power Supply Unit (PSU)	BRPSU672A (initially built in) – can also be ordered for spares	
19" Rack Installation Dimension	IEC297-1 (EIA RS 310-D) 465.1mm (front face screw pitch – width)	
Installation	Cannot be floor or wall mounted.	
Optional Equipment	Power Strip Box <sup>1</sup>	BRPSB120A
		BRPSB240A
	Reserve Power Battery Distribution Box <sup>2</sup>	BBDB1A
	From PSU to Battery Cable	PBTC1A-3M
	From BBDB to Battery Cable	BBTC1A-2.0M
	AC240V Power Supply Cord	BACL240A

1. Power strip boxes for floor/wall-mountable cabinets cannot be used for Rack Mount cabinets.

2. Reserve batteries are connected using the same battery distribution box and battery cables as the CIX670 and CIX1200 floor/wall-mountable cabinets.

## Base Cabinet

The CIX670 and CIX1200 rack mount base cabinet is similar to the Strata CIX670 and CIX1200 wall mount base cabinet. It has two dedicated slots used for the system processor cards and eight universal slots, labeled “S101~S108,” that can accommodate station, CO line or option circuit cards. It also houses a power supply. See [Figure 9](#).

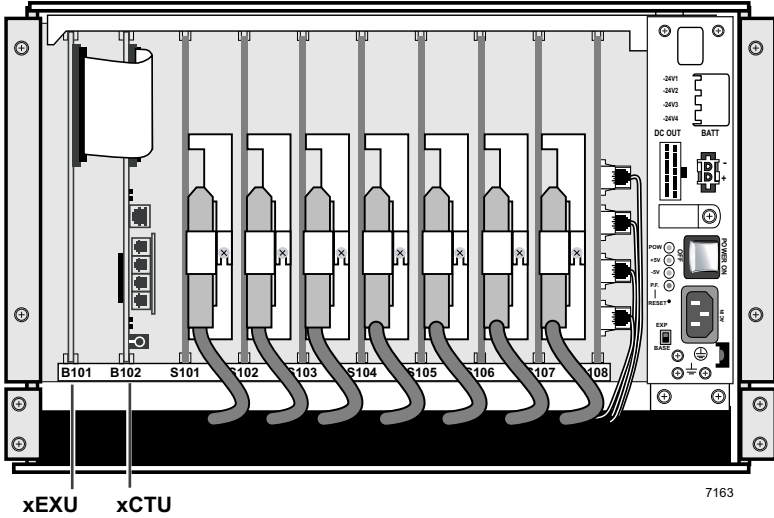

Figure 9 Strata CIX670 and CIX1200 Rackmount Base Cabinet Interior

## Expansion cabinet

Each expansion cabinet provides 10 slots (S\_01~S\_10). [Figure 10](#) shows an Expansion Cabinet.

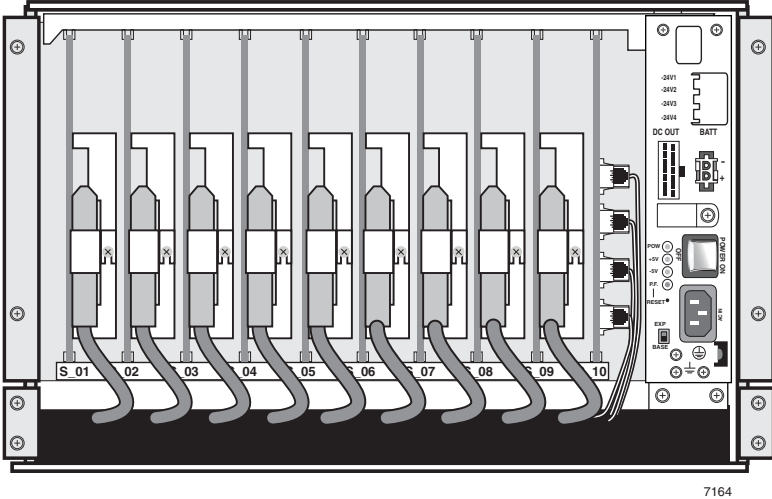

Figure 10 Strata CIX670 and CIX1200 Rackmount Expansion Cabinet Interior

## **CIX670 and CIX1200 Remote Expansion Cabinet**

A CIX670 and CIX1200 Expansion Cabinet can be located between a few inches and up to three kilometers (1.86 miles) from its Base Cabinet. Remote Expansion Cabinets are enabled by the fiber optic RRCU interface cards. One RRCU connects to up to two Data Cables and applies the inter-cabinet signal to a multi-mode fiber-optic pair. One fiber pair can support one or two Expansion Cabinets in one remote location using one RRCU in the Base Cabinet and another in one of the Remote Expansion Cabinets.

CIX1200 expansion cabinets 8 through 12 must be connected as remote cabinets using RRCU interface cards and multi-fiber optic cables.

Fiber connected cabinets support the BIOU for external Page Zones, Night Bell, etc., and all CO line and trunk interface circuit cards. Network clock synchronization can only be derived from digital trunks installed in the Base Cabinet or a expansion cabinet connected with standard ribbon cables, not fiber cables.

A Remote Cabinet can support all circuit cards that can be installed in a local Expansion Cabinet, including digital trunk cards. However, the system cannot derive network clock synchronization from a digital trunk installed in a Remote Cabinet. This requires a digital trunk installed in the Base Cabinet or in a local Expansion Cabinet connected to the Base by a standard ribbon cable. For each Remote Cabinet location, local trunks may be required for correct 911 service.

Universal Printed Circuit Cards installed in the Strata CIX1200, CIX670, CIX200 or CIX100 cabinets provide interfaces for stations, lines, and peripherals. Each circuit card measures 7.5 x 5.5 inches (190 x 140 mm) and mounts in the slot with a 44-pin backplane connector. Circuit Card external connections to station equipment are made to the Main Distribution Frame (MDF) using industry-standard connectors.

**Important!** *This chapter does not apply to the Strata CIX40, except for GVPH, GIPU8, MIPU16 and MIPU24.*

## Station, Line and Option Circuit Cards

The Circuit Cards are categorized as station, CO line or option cards (see [Tables 11~13](#)). Feature subassemblies that plug onto a universal slot circuit card are listed below the associated card. For details, see the *Strata CIX I&M Manual*.

**Table 11 Station circuit cards**

<b>Internet Protocol Telephone (IPT) Interface Unit (MIPU, LIPU/LIPS, GIPU and GIPH)</b>	
Provides IPT telephone circuits (IP5000-series, IPT2010-SD, IPT2020-SD and IPT2008-SDL) 1 100Base-TX RJ45 port Built-in Digital Signal Processor (DSP) 1 RS-232 maintenance port Network Address Translation (NAT) compatible for remote IP telephones when connected to a MIPU / LIPU. Enhanced version of MEGACO+ for Voice over IP Supports SIP telephones and UIP200 Simultaneously supports Line interfaces.	MIPU16 – supports 16 IP channels (supported by CIX40 R1 and R2 cabinets) MIPU24 – supports 24 IP channels (supported by CIX40 R2 cabinet) LIPU-X1A – supports 16 IP channels LIPS-X1A – supports 16 IP channels and mounts on LIPU LIPU/LIPS is not supported by CIX40 GIPU8, GIPH-X1A – supports 8 IP channels for CIX40 only Interface Options: LAN, Virtual Private Network (VPN) Internet, VPN WAN, Intranet.
<b>Digital Telephone Interface Unit (ADKU, BDKU/BDKS, BWDKU1A)</b>	
Provides digital telephone circuits for DP5000-series, DKT3000/3200-series digital telephones. Stand-alone digital cordless telephone DDM5060 console DDS3260 console DDCB – Door Phone Stand-alone digital cordless telephone DDM console BATI – Digital Attendant Console	ADKU = 8 circuits (CIX100 only) BDKU = 8 circuits BDKS = 8 circuits BWDKU = 8 circuits

## Universal Slot Circuit Cards

Station, Line and Option Circuit Cards

**Table 11 Station circuit cards (continued)**

<b>Standard Telephone Interface Unit (LSLU - CIX200 only) (ASTU - CIX100 only)</b>	
Provides two standard telephone circuits. Maximum number of ringers per circuit is one.	Interface Options: Standard telephones (no message waiting lamp control - no OPS (48V)) Other single-line devices Alternate MOH/BGM source Fax machines Voice mail devices
<b>Standard Telephone Interface Unit (Card Slot Mount) (BSLU/BSLS - All CIX Systems)</b>	
Provides eight (BSLU) or 16 (BSLU + BSLS) standard telephone circuits. Maximum number of ringers per circuit is one	Interface Options: Standard telephones (no message waiting lamp control) Other single-line devices Alternate MOH/BGM source Fax machines Voice mail devices No 48 Volt Off-premises Station support
<b>Standard Telephone Interface Unit with Caller ID (Card Slot Mount) (BSTCIU - All CIX Systems, except CIX40)</b>	
Provides eight standard telephone circuits with Caller ID. Maximum number of ringers per circuit is three.	Interface Options: Standard telephones with Caller ID displays Message Waiting Lamp Control Off Premise Station (OPS) VM devices MOH / BGM
<b>Standard Telephone Interface Unit (BSTU)</b>	
Provides 8 standard telephone circuits. Stutter dial tone is provided for Message Waiting audible indication.	<b>Interface Options:</b> Standard telephones Voice mail ports Off-premises stations Other similar devices Alternate MOH/BGM source Auto Attendant digital announcer Message Waiting Lamp Control Fax machines ACD announcer
<b>-48 Volt Supply Internal Option (R48S)</b>	
Attaches to BSTU and BSTCIU 48VDC circuit for up to 8 standard telephone circuits. Not available on LSLU, BSLU/BSLS, ASTU	Interface Options: Optionally interfaces to the BSTU and BSTCIU to extend loop length of standard telephones from 600 ohms to 1200 ohms. Required for OPS operation.
<b>Voice Mail</b>	
GVPH (CIX40 only)	Pre-programmed Voicemail Auto attendant circuit card. 4 Voice mail / Auto attendant ports default; 6 and 8 ports require LIC-2 GVPH 40 hours storage – 360 mail boxes Call record, Voice mail Call monitor and built-in modem
LVMU1A (CIX100, CIX200, CIX670, and CIX1200)	Pre-programmed Voicemail Auto attendant circuit card. 8 Voice mail / Auto attendant ports 40 hours storage – 360 mail boxes Call record, Voice mail Call monitor and built-in modem



**Table 11 Station circuit cards (continued)**

Stratagy IVP8 R2 (CIX100, CIX200, CIX670, and CIX1200)	Supports up to 8 ports, approx. 15 hours of voice storage. 512MB CompactFlash card upgrade provides approx. 30 hours of voice storage. Circuit Card has flash memory, 2 RS-232 ports (1200~9600 bps) for local or remote PC interface. (See <i>Stratagy General Description</i> for details).
Stratagy iES32 (CIX100, CIX200, CIX670, and CIX1200)	Preprogrammed for plug-and-play in CIX Base or Exp., provides 4~32 voice ports. Also supports fax server and Unified Messaging (UM). 10/100BaseT Ethernet connection and a serial port used for Toshiba Proprietary Integration (TPI). (See <i>Stratagy General Description</i> for details).
Stratagy iES16 (CIX100, CIX200, CIX670, and CIX1200)	The Stratagy iES16 is an integrated voice mail system that can be installed in a card slot inside a Strata CIX system. The Stratagy iES16 supports a maximum of 16 voice ports, and is available in model increments of 4 ports (4, 8, 12, 16 ports). The Stratagy iES16 also ships with Unified Messaging and 5 client seats standard, and can be configured for all of the advanced applications of the iES32, specifically up to 4 channels of fax and 8 channels of Text to Speech.

**Table 12 CO Line Circuit Cards**

<b>Strata Net Over VoIP Interface Unit (MIPU, LIPU/LIPS, GIPU and GIPH)</b>	
Provides 32 IP Strata Net channels 1 100Base-TX RJ45 port 1 RS-232 maintenance port Based on IP Strata Net standard protocol (ECMA-336) Voice coding G.711/G.729A Built-in Digital Signal Processor (DSP) Simultaneously supports IPT Station interfaces	MIPU16 – supports 16 IP channels MIPU24 – supports 24 IP channels LIPU-X1A – supports 16 IP channels LIPS-X1A – supports 16 IP channels and mounts on LIPU LIPU/LIPS is not supported by CIX40 GIPU8, GIPH-X1A – supports 8 IP channels for CIX40 only <b>Interface Options:</b> LAN, Virtual Private Network (VPN) Internet, VPN WAN, Intranet.
<b>SIP Trunking (MIPU)</b>	
Provides 24 IP Strata Net channels 1 100Base-TX RJ45 port 1 RS-232 maintenance port Voice coding G.711/G.729A Built-in Digital Signal Processor (DSP) Simultaneously supports IPT Station interfaces	GIPU8 – supports 8 IP channels MIPU16 – supports 16 IP channels MIPU24 – supports 24 IP channels
<b>Internet Protocol (IP) Interface Unit (BVPU)</b>	
Provides 4 VoIP Circuits as E&M Tie lines 1 10Base-T port 1 RS-232 maintenance port H.323 standard for Voice over Internet Protocol (VoIP)	<b>Interface Options:</b> LAN, Internet, WAN.
<b>Caller ID Interface Unit (RCIU2 / RCIS)</b>	
Provides 4 Caller ID circuits. With RCIS: 8 circuits.	<b>Interface Options:</b> Provides Caller ID LCD display for analog loop or ground start lines with Caller ID. Requires: RCOU, RCOS, RGLU2, RGLU3 or PCOU. Not compatible with T1.
Caller ID Interface Subassembly (RCIS) Attaches to the RCIU2.	Same as RCIU2.
<b>Direct Inward Dialing Interface Unit (RDDU)</b>	
Provides 4 DID circuits.	<b>Interface Options:</b> DID analog lines.

## Universal Slot Circuit Cards

Station, Line and Option Circuit Cards

**Table 12 CO Line Circuit Cards** (continued)

<b>Enhanced 911 CAMA Trunk Interface Unit (RMCU/RCMS)</b>	
E911 CAMA circuits. Provides up to 4 CAMA trunk circuits. The RMCU/RCMS eliminates the need for connection of adjunct terminal adapter equipment to E911 CAMA trunks. Requires 1 or 2 RCMS circuit cards for 2 or 4 CAMA lines respectively.	E911 analog CAMA trunks.
CAMA Trunk Subassembly (RCMS) RCMS attaches to RMCU. Provides 2 E911 CAMA circuits. Up to 2 RCMSs per RMCU for 4 CAMA lines max. (1 RCMS comes packaged with the RMCU.)	Same as RMCU.
<b>Ground/Loop Start Interface CO Line Interface Unit (RGLU3)</b>	
Provides 4 ground or loop start line circuits. Each can be individually set for ground or loop start operation.	<b>Interface Options:</b> Analog loop or ground start analog lines.
<b>ISDN Primary Rate Interface Unit (RPTU and BPTU)</b>	
Provides (1~8B + D), (1~16B + D), or (1~23B + D) channels (lines), depends on system programming. RPTU2 is required for Strata Net Networking.	<b>Interface Options:</b> ISDN PRI POTS FX Tie (senderized) Tie (cut through) OUTWATS (intra-LATA) and (inter-LATA) InWATS Strata Net
<b>Loop Start CO Line Interface Unit (RCOU3A and RCOS3A)</b>	
Provides 4 CO analog loop start line circuits. With RCOS, provides 8 CO analog loop start line circuits.	<b>Interface Options:</b> CO analog loop start lines
Loop Start CO Line Interface Subassembly (RCOS) Provides 4 additional Loop Start CO lines. 1 RCOS subassembly per RCOU.	Same as RCOU. RCOU/RCOS requires RCIU2/RCIS to support Caller ID.
<b>Loop Start CO Line Interface with Caller ID Unit (BCOCIU1A)</b>	
Provides four CO analog loop start line circuits. With BCOCIS1A, provides eight CO analog loop start line circuits. Caller ID interface is built-in, RCIU is not needed.	<b>Interface Options:</b> CO analog loop start lines (Does not support Type 2 Hook-Flash to answer a waiting call, does not provide dial pluse output)
Loop Start CO Line Interface Subassembly (BCOCIS1A) Provides 4 additional Loop Start CO lines with built-in Caller ID interface. Mounts on the BCOCIU1A.	Same as BCOCIU1A.
<b>T1/DS-1 Interface Unit (RDTU)</b>	
Provides T1 (DS1) Interface: 1~8, 1~16, or 1~24 channels (lines), depends on system programming.	<b>Interface Options:</b> T1 Loop start lines Ground start lines Tie lines (wink or immediate) DID/DOD lines (wink or immediate)
<b>Remote Expansion Cabinet Unit (RRCU)</b>	
Supports 2 CIX670 and CIX1200 remote cabinets. 62.5 μm, multi-mode fiber.	Remote Cabinet not supported by main system reserve power.

**Table 12 CO Line Circuit Cards** *(continued)*

<b>Tie Line Unit (REMU2)</b>	
Provides 4 analog Tie line circuits.	<b>Interface Options:</b> E&M Tie lines 2- or 4-wire transmission Type I and type II signaling Immediate start Wink start

**Table 13 Option Circuit Cards**

Option Interface Unit (BIOU)	<b>Interface Options:</b> Provides Paging output (600 ohm and 3-watt amp), 4 zone paging relays, three MOH interfaces and 4 control relays (Night Transfer and BGM mute).
Option Interface Unit (BSIS)	<b>Interface Options:</b> Provides four RS232 ports.

# Functional Block Diagrams

The Functional Block Diagrams show the circuit cards and interface connectors used for connecting the stations and peripherals (see Figures 11~15).

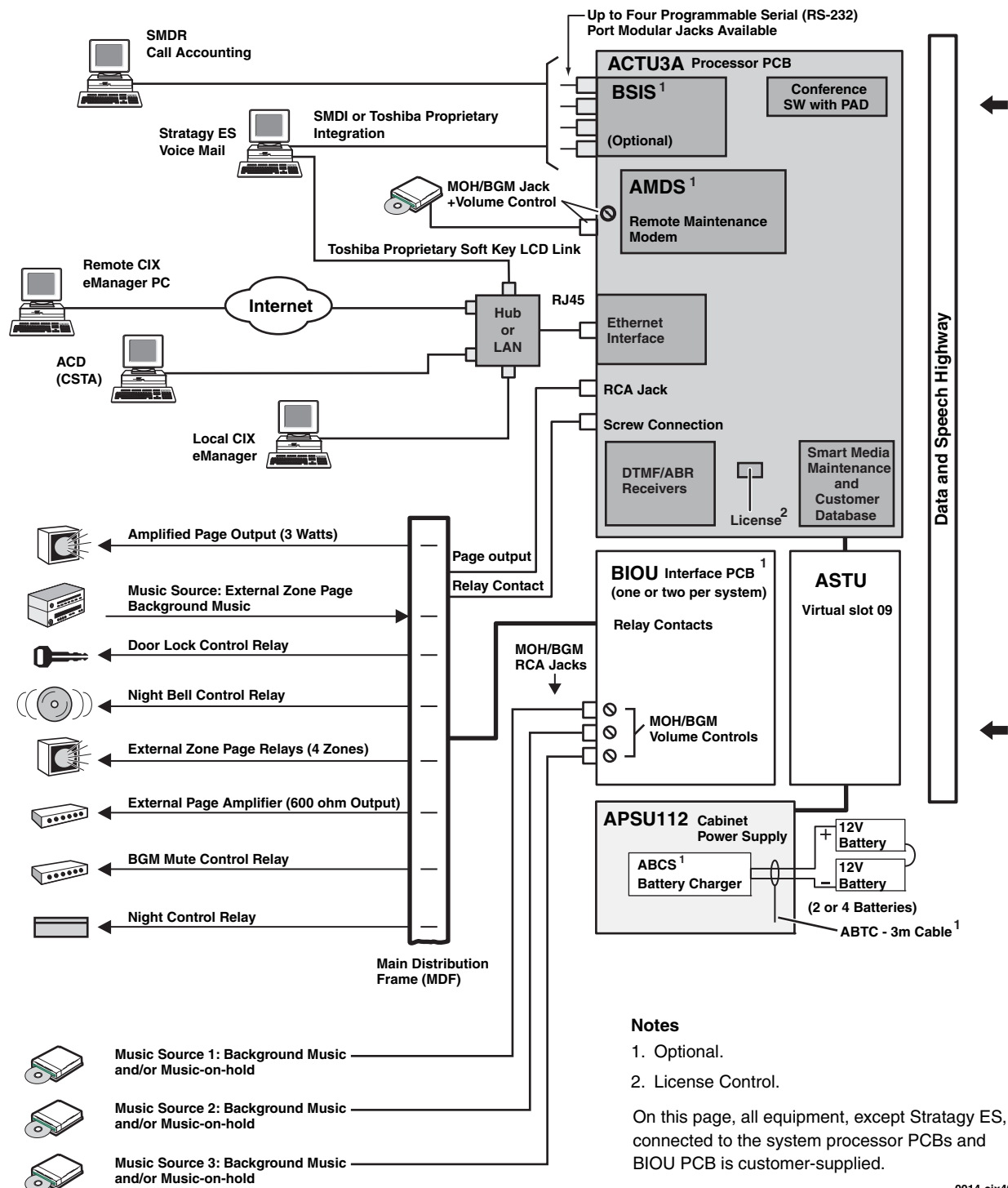

**Notes**

- 1. Optional.
- 2. License Control.

On this page, all equipment, except Strategy ES, connected to the system processor PCBs and BIOU PCB is customer-supplied.

0014-cix40

Figure 11 CIX100 System Processor and Optional Interface Circuit Cards

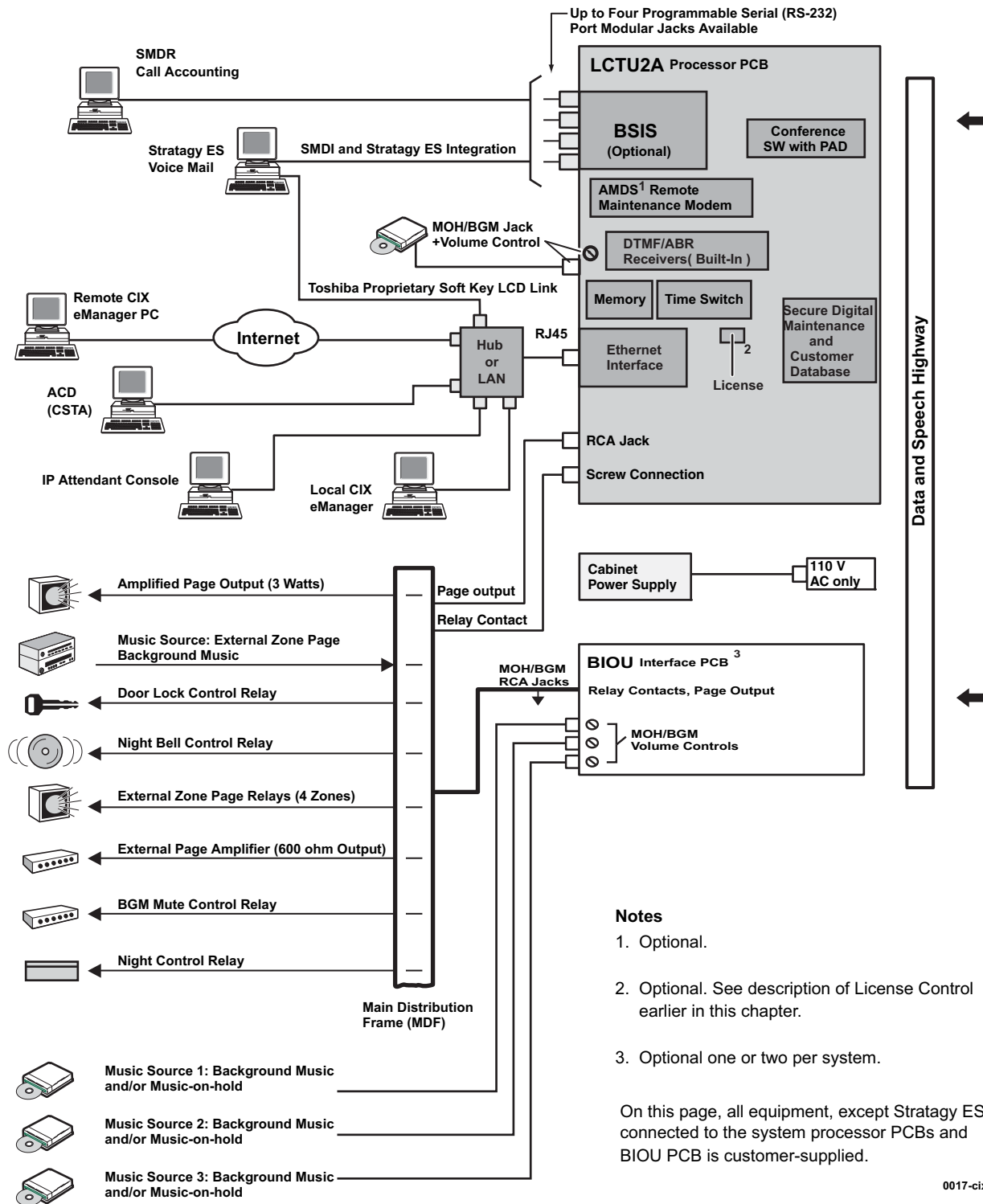
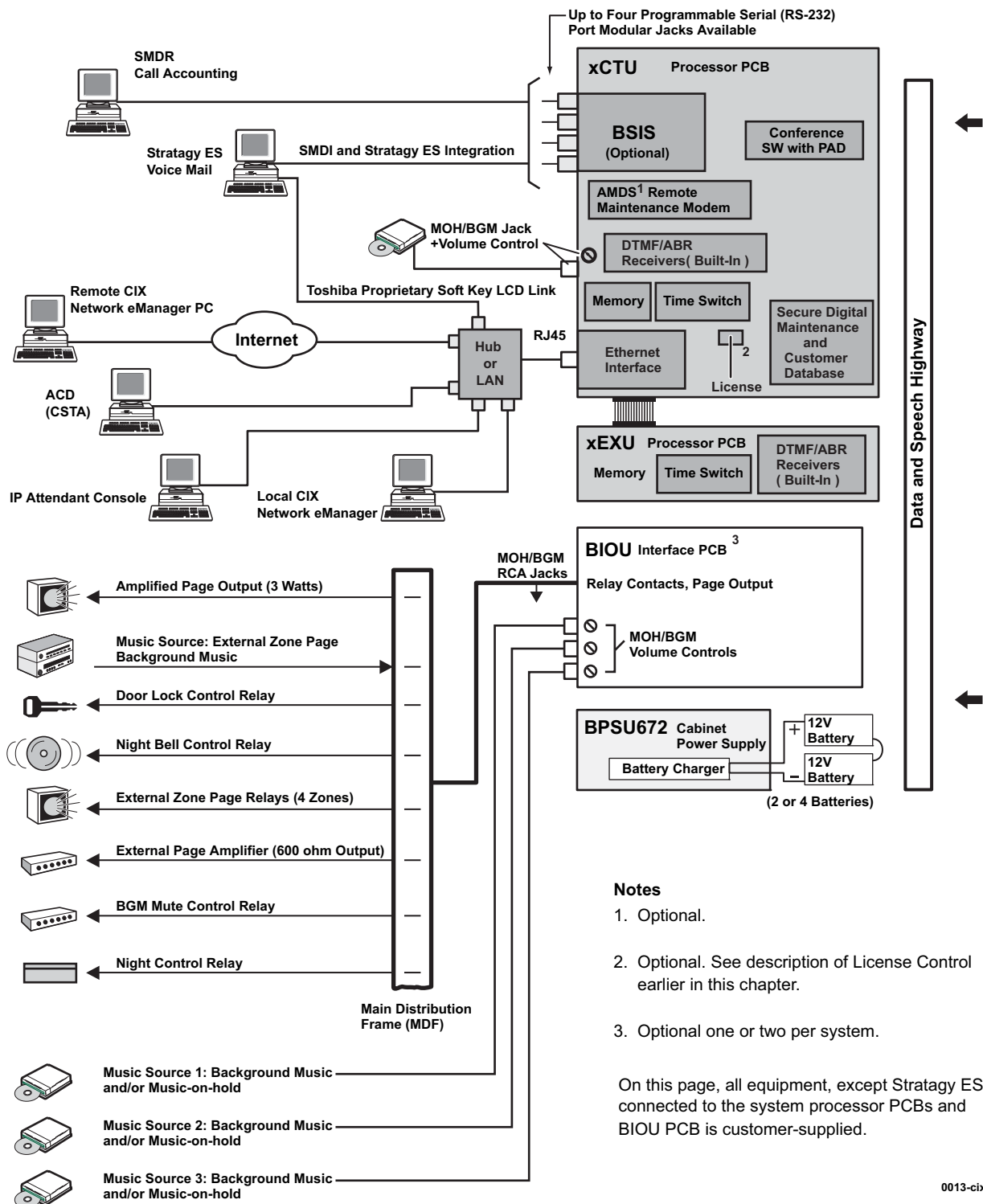

Figure 12 CIX200 System Processor and Optional Interface Circuit Cards



0013-cix40a

Figure 13 CIX670 and CIX1200 System Processor and Option Interface Circuit Cards

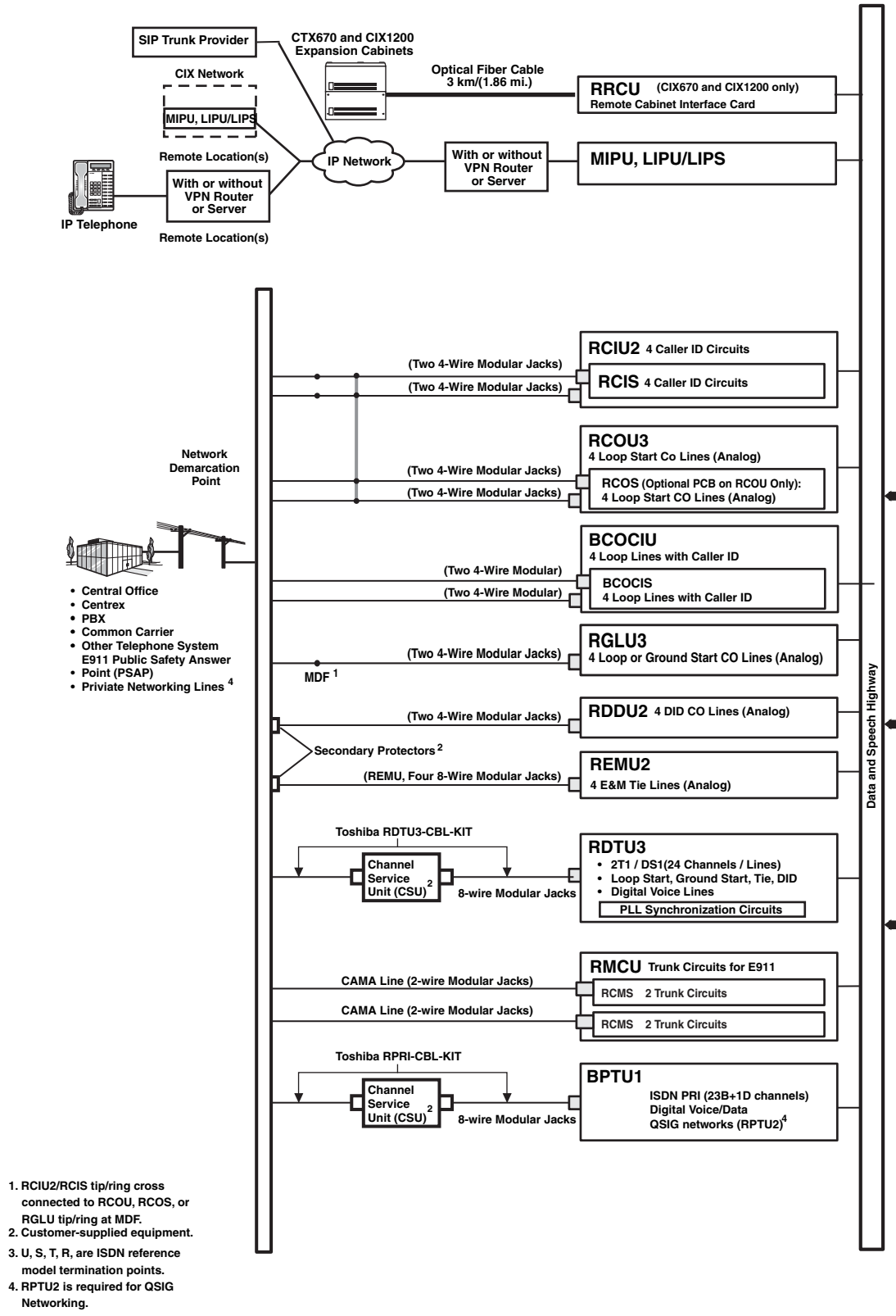
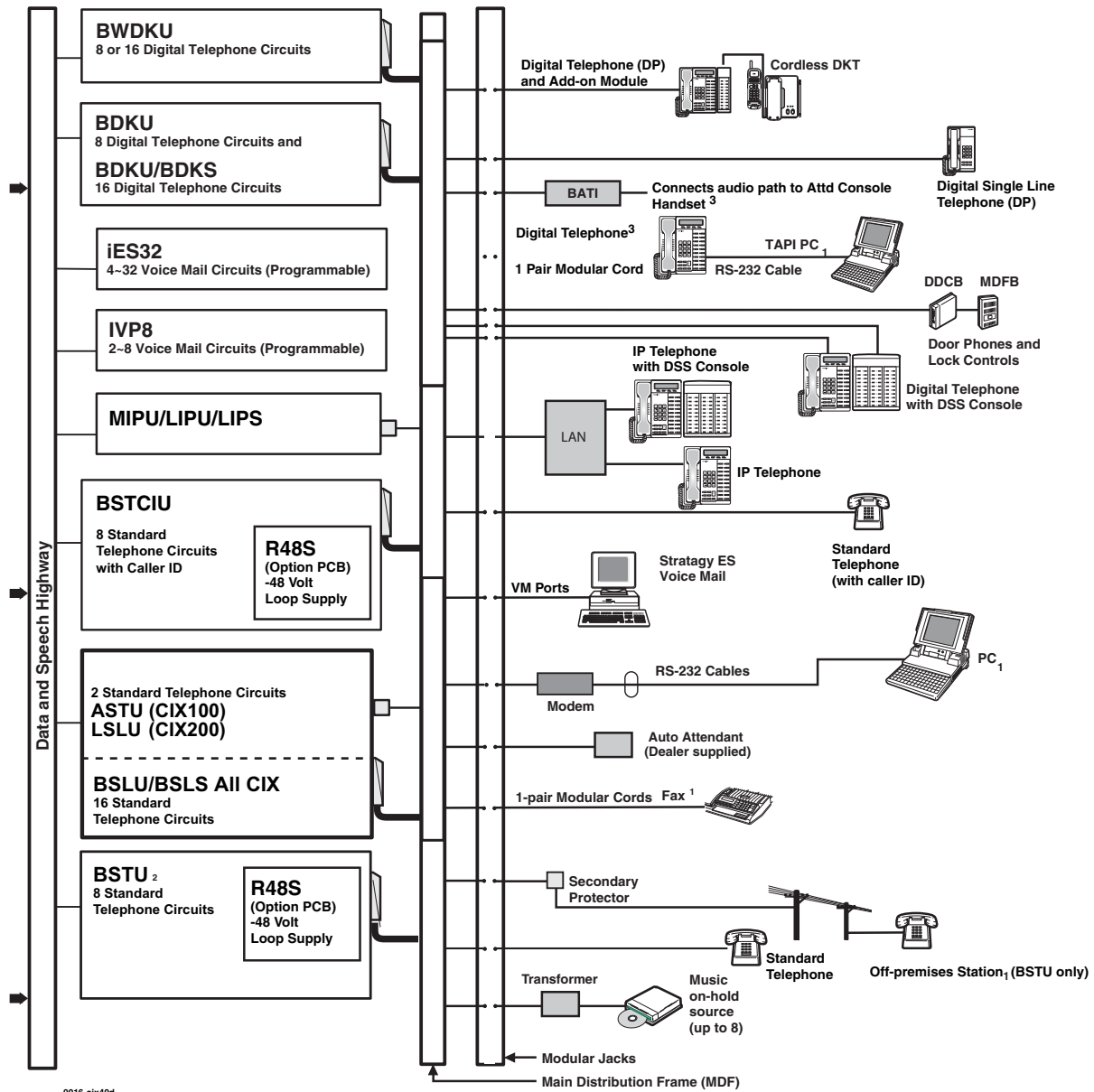

Figure 14 CIX100, CIX200, CIX670, and CIX1200 CO Line Side Functional Block Diagram

# Universal Slot Circuit Cards

## Functional Block Diagrams



1. Customer-supplied equipment.
2. RSTU2 or above is required for standard telephone message waiting lamp.
3. PDKU and RDSU should only be used for 2000-series digital telephones. They do not support all of the 3000-series and 5000-series digital telephone features, including LCD. The PDKU also does not support BPCI, BATI and the CTX Attendant Console.

Figure 15 Strata CIX100, CIX200, CIX670, and CIX1200 Station Side Functional Block Diagram



This chapter covers Toshiba's 5000-series Digital Telephones (DP), Internet Protocol Telephones (IP) and peripherals that are compatible with Strata CIX telephone systems.

## DP5000-series Digital Telephones

The DP5000-series telephones replace the DKT3200-series telephones in the Toshiba product line.

All three generations of telephones, DKT2000, DKT3200 and DP5000, can co-exist with full functionality in one Strata CIX system with Release 5.1 software or above.

Although the DP5000-series telephones can be used on a CTX28 they will have limited functionality.

The DP5000 telephones have three operational modes:

- When connected to Strata CIX systems with Release 5.1 or above, they will automatically run in DP5000 Mode.
- When connected to Strata CIX systems with older than Release 5.1 (including Release 3) the DP5000-series telephones will automatically act as DKT3200 telephones; DP5000-series telephones can also be programmed to act as DKT2000 telephones.
- When connected to a PDKU card DP5000-series telephones automatically act as DKT2000 telephones.
- The DP5000 Backlight feature will function on all Strata CIX systems, regardless of the system software version.

### DP5000-series Telephone Illustrations



20 Programmable Feature Buttons 4-Line LCD Telephone



Single Line Telephone 1 Programmable Button

#### Legend

- A. Status LED (message and ringing)
- B. LCD Display
- C. Softkeys
- D. Programmable Feature Buttons
- E. Message Waiting LED Button
- F. Microphone LED Button
- G. Speaker LED Button
- H. Volume
- I. Hold Button
- J. Microphone
- K. Tilt stand
- L. Off-Hook Button (Single Line Telephone)

**DP5008**

Digital Single Line Telephone



**DP5018-S**

Digital Speakerphone with 10 programmable buttons



**DP5022-SDM (CIX40 only)**  
**DP5022-SD**  
**DP5122-SD**

Digital Speakerphone with 10 programmable buttons 4-line LCD display



**DP5032-SD**  
**DP5132-SD**

Digital Speakerphone with 20 programmable buttons, 4-line LCD display with backlight option (shown with KM5020)



**DP5130-SDL and DP5130-FSDL**

Digital half duplex and full duplex speakerphone options with 20 programmable buttons, 9-line LCD display with backlight.



## **The DP5000 Look**

- Sleek low profile — less than 1-inch thick.
- Black body with dark gray keys.
- Metallic silver curved tilt stand with eight adjustable positions.

## **Large Display Area for Call Information**

- New LCD Technology — High Contrast LCD panel.
- All LCDs are 24 characters wide.
- Four lines of LCD to display call information (on the DP5022-SDM, DP5022-SD, DP5122-SD, DP5032-SD, and DP5132-SD telephones).
- Nine lines of LCD on the DP5130-SDL and DP5130-FSDL telephones.
- Advisory Messages.
- Automatic Number Identification (ANI).
- Caller ID, Name and Number with call history.
- Contrast adjustment (13 levels).
- Date/Time of Day.
- Dialed Number Identification Service (DNIS Name and Number).
- Feature Prompting Soft Keys that are used as an alternative to access codes or feature buttons. Station users can access features by responding to LCD prompts.
- Called Number displays on outgoing calls (1~120 seconds).

## **LCD Key-Strip**

- Integrated in the DP5130-SDL and DP5130-FSDL telephones.
- Integrated in the LM5110 add-on module. This module is supported on all of the DP5000 series telephones except the DP5008.
- Key labels are programmable via eManager, MyPhone Manager (both local and remote), or user programming mode.
- User programmable line and trunk labels.
- Feature labels – user selectable.
- Ease of deployment and dynamic changes.

## **Backlight LCD**

- Available on: DP5122-SD, DP5132-SD, DP5130-SDL, DP5130-FSDL, and LM5110.
- Place the telephones anywhere: regular office, reception area, high-end home studio, hotel lounge, low-light environments, etc.
- LCD backlight can be set to always on, always off or synchronized which turns backlight on anytime activity is sensed on the telephone and will automatically shut off after a period of time to conserve energy.

## Mic Mute

**Note** Not supported on DP5008.

- All models have microphone and half duplex speaker capability.
- Enhanced Mute – the handset and microphone are muted simultaneously.
- The MIC key on the telephones toggles between Mic and Mute. When Mic key is lit, hands free communication is supported, when the Mic key is pressed and light is off, Mute is enabled.

## Handset/Headset

- Built-In Headset Interface.
- Built-in Carbon Handset Interface controlled by software.
- Speaker Off-hook Call Announce (OCA) for all models except on the DP5008. Speaker OCA requires the DOCA interface.

**Note** The CIX40 supports Handset Off-hook Call Announce (OCA) but not Speaker OCA.

- On hook dialing.

## Shift and Hist Keys

The bottom left and right keys on the large screen telephones are called the Shift and Hist keys. The Shift key toggles the LCD screen between flexible keys 1~10 and flexible keys 11~20. The Hist key accesses the Caller ID history. These buttons have no function when the telephone is connected to a Strata CIX system running on software released prior to R5.2 MT021.

## Speaker Off-hook Call Announce (DOCA-1A)

Digital telephones equipped with DOCA-1A can receive Speaker OCA which enables stations to receive internal calls over their speaker while on another call using the handset. The DOCA-1A is not required in a telephone to originate OCA calls or in a digital telephone that receives OCA calls through the handset or headset.

Speaker OCA Interface (DOCA-1A) cannot be installed in DP5008 telephones.

## DP5000-Series Telephone Tilt Angles

The DP5000-series telephones, except the DP5008, have three tilt positions built into the base. There is also a tilt stand extension that adds an additional 20 degrees of tilt. When the telephone is sitting on a desk or table there are a total of six different angles of tilt available. When wall mounted there are two angles available.

The DP5008 base is fixed at 15 degrees. All other DP5000-series telephones and add-on module can tilt at 15°, 27.5°, 35°, 40°, 47.5°, and 60°.

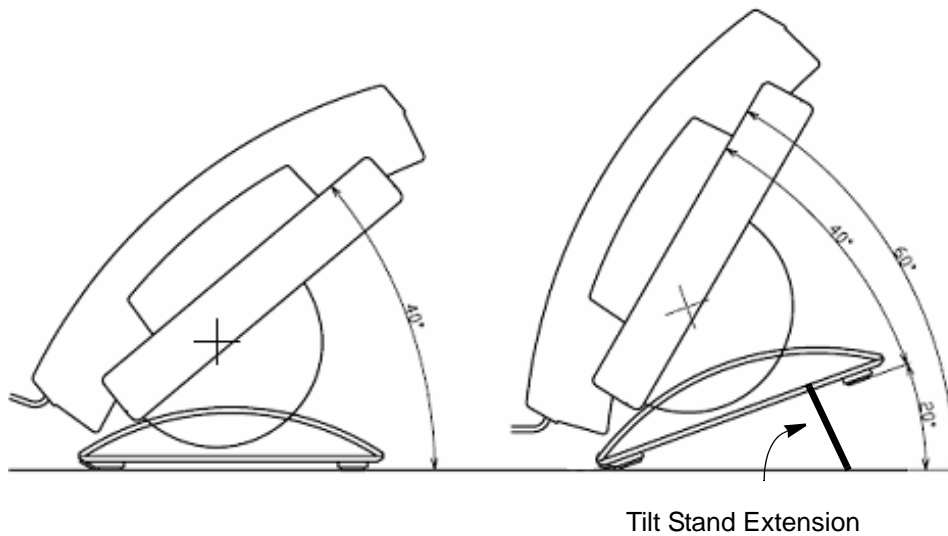

Figure 16 DP5000-Series Desk-top Tilt Angle With Tilt-Stand Extension

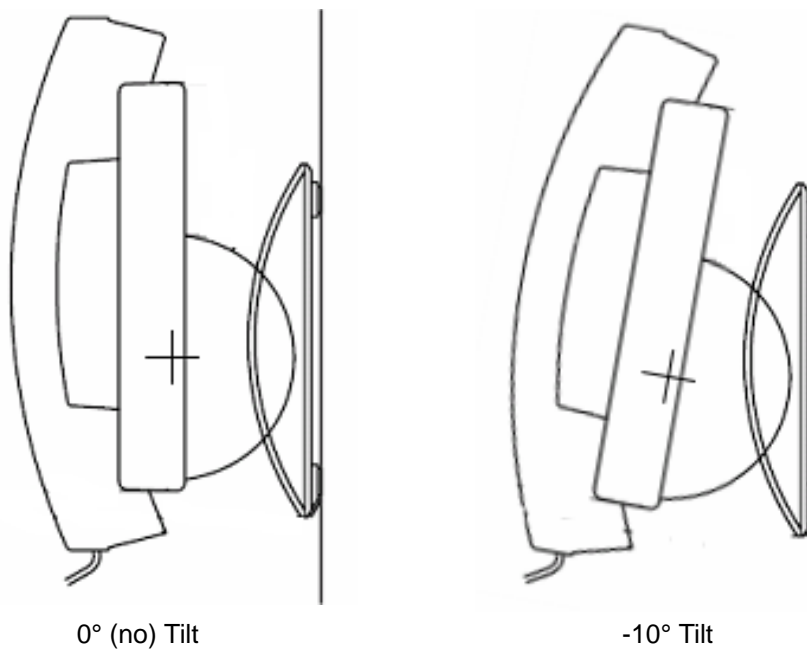

Figure 17 DP5000-Series Wall Mount Angles

## Telephone Button Expansion Options

Add-on modules connect directly to the telephones and do not require an additional interface circuit (port). Up to two Add-on-Modules can be attached to a telephone to supplement the telephone's 10 or 20 buttons.

The CIX supports a limited number of Add-on-Modules per cabinet (see [Table 51 on page 177](#) for the capacities of different common control units).

Expansion options for the Toshiba DP5000-series telephones are described below:

### LCD Add-on -Module (LM5110)

The LM5110 adds 10 programmable LCD feature buttons to the 5000-series telephones, these buttons can be assigned as CO line, Directory Number, DSS, One Touch, Speed Dial or any other flexible feature.

The LM5110 supports backlight and LCD labels, it can be connected to any 5000-series telephone (except DP5008).



LM5110 shown with DP5130 Telephone

### Key Module (KM5020)

The KM5020 adds 20 programmable feature buttons to the 5000-series telephones. These buttons can be assigned as CO line, Directory Number, DSS, One Touch, Speed Dial or any other flexible feature.



KM5020 shown with DP5132-SD Telephone

### Digital DSS Add on Module (DDM5060)

The DDM5060 console (shown right) is for system attendants.

The DDM5060 operates alongside a digital telephone and has 60 programmable feature buttons. These buttons can be assigned as CO Line, Directory Number, DSS, One Touch, Speed Dial or any other flexible feature. The DDM5060 is not compatible with the DP5008.

Up to eight consoles can operate with one digital telephone depending on CIX system (See [Table 51 on page 177](#)).



DDM5060 shown with DP5132 Telephone

The DDM5060 console uses LEDs to indicate call and feature status; the DSS has dual red and green LEDs to help further define status, such as station in DND status. The DDM5060 console connects to a digital station port on the ADKU, BDKU, or BDKS card.

## Cordless Digital Telephones

Toshiba offers three cordless digital telephone models, the DKT2404-DECT, DKT2204-CT and the DKT2304-CT (see photos in this section). These compact cordless digital telephones bring mobility and productivity to office telephones. Greater call access cuts down on leaving messages and playing “telephone tag.”

The DKT2404-DECT delivers the DECT functionality for the Strata series of cordless digital telephones. DECT technology minimizes any interference between base stations in proximity or any surrounding WLAN access points.

The DKT2404-DECT provides a 24-character display for better compatibility with the Toshiba DP5000 Series desk phones versus 16 characters on other cordless phone models. It provides four programmable keys with an additional four speed dial keys.

The digital cordless telephones operate from the same digital station port as the DP5000-series digital telephone. They can be attached to a Toshiba DKT3000- or 2000-series corded digital telephone or used as a stand-alone. If a cordless telephone is attached to a DP5000, the DP5000 must be put into 2000 mode.

Some of the features the cordless models include:

- Liquid Crystal Display (LCD) that wraps using two lines, total of 32 characters
- Ringer and handset volume control
- Single button access to: Conference, Hold, Redial, Message and Transfer features
- Four programmable function buttons
- Charging stand
- AutoStandby
- AutoTalk
- Vibrate ringer alert
- Out-of-range protection
- Low-battery protection system
- Headset jack (2.5mm)
- Stand-alone or DKT operation
- High quality ultra-secure conversation with 32Kbps Adaptive Differential Pulse Code Modulation (ADPCM) voice code combination.
- Three ring tones

### Notes

- They cannot receive Group Pages or All Call Pages.
- The handset and base unit of each cordless telephone is equipped with the same security code. In order for a handset to operate, it must be installed with the matching base unit.

Below is the feature comparison table of the DKT2404-DECT, DKT2204-CT and DKT2304-CT.

**Table 14 DKT2404-DECT, DKT2204-CT and DKT2304-CT Feature Comparison**

Feature	DKT2404-DECT	DKT2304-CT	DKT2204-CT
<b>Transmission</b>	1.9 GHz DECT 6.0	900 MHz Digital Narrow Band	900 MHz Digital Spread Spectrum
<b>Number of Channels</b>	5 Channels	30 Channels	10 Channels
<b>Talk Time</b>	16 Hours	7 Hours	6 Hours
<b>Stand By Time</b>	168 Hours	120 Hours	96 Hours
<b>Battery Type</b>	NiMH Battery	NiMH Battery	Ni-Cd Battery



## DKT2404-DECT

Combined with the DKT2404-UDR100 repeater solution, the DECT technology provides three to seven times the range compared to the DKT2204-CT and DKT2304-CT models. Up to six repeaters can be linked per base station, with up to three capable of being daisy-chained in one direction, to extend operation range to greater than 1000 feet in open areas.

The DKT2404-DECT battery life is sixteen hours talk time and seven days standby time.

The DKT2404-DECT Phone provides:

- Two-line LCD with 24-character display, plus one line for icons.
- Dedicated Talk, Redial, Hold, Msg, Cnf/Trn, Menu/MUTE, Speaker keys.
- Four programmable keys plus four speed dial keys.
- Handset measurements in inches: 2.25 wide x 1.0 deep x 6.5 tall. For base and charger measurements, see [Table 40 on page 167](#).



DKT2404-DECT shown with charger and Base



DKT2404-UDR100

## DKT2204-CT

The DKT2204-CT uses 900MHz Digital Spread Spectrum Technology. It's the reduces unwanted interference and provides superior voice communication security.

The DKT2204-CT provides:

- The range is two to three times greater than analog cordless telephones.
- Good clarity that is indistinguishable from corded telephones in most environments.
- Maximum security for up to 10 cordless digital telephones that is almost impossible to scan.
- A wall-mountable separate base and charging unit are provided with the telephone.

Handset measurements in inches: 2.2 wide x 1.66 deep x 8.66 tall. For base and charger measurements, see [Table 40 on page 167](#).

**Note** The DKT2204-CT works with Strata CIX and Strata DK telephone systems.



6828

## DKT2304-CT

The DKT2304-CT uses 900 MHz Digital Narrow Band technology that provides:

- A range of two to three times greater than conventional analog cordless telephones.
- Good clarity.
- Maximum security for up to 30 cordless digital telephones.

This DKT2304-CT handset is much smaller than previous models. Measurement in inches: 2.0 wide x 1.25 deep x 5.5 tall. For base and charger measurements, [Table 40 on page 167](#).



6829

## IP 5000-Series IP Telephones

The IP5000-series telephones replace the IPT2000-series telephones in the Toshiba product line.

IPT2000- and IP5000-series telephones can coexist with full functionality in one Strata CIX system, Release 5.2 software, or above.

The IP5000-series telephones have three operational modes:

- When connected to Release 5.2 CIX systems with LIPU or MIPU interface cards, they will automatically run in IP5000-series mode.
- When connected to CIX systems with older than Release 5.1 (including Release 3), the IP5000-series telephones will automatically act as IPT2000-series telephones.
- If the interface is a BIPU-M, the IP5000-series telephones will run in IPT2000-series mode.

Strata CIX40, CIX100, CIX200, CIX670, and CIX1200 systems running R4 and later software can be upgraded to Release 5.2 software. Systems running R3 must be updated to R4 processors then updated to R5.2.

Strata CTX28 systems do not support IP telephones.

Toshiba offers five IP Telephone models with backlight displays (except IP5022-SD), full-duplex speakerphones, and Gigabit Ethernet:

- **IP5122-SD** – 10-button IP speakerphone with 4-line x 24-character backlit LCD
- **IP5022-SD** – 10-button IP speakerphone with 4-line x 24-character LCD (without backlight)  
The IP5022-SD has all the same characteristics as our IP5122-SD except the backlight for the display. This telephone still has full feature functionality as well as Gigabit Ethernet and with its 4-line display and 10 programmable buttons.
- **IP5122-SDC** – Looks and functions similar to the IP5122-SD telephone when connected to the Strata CIX. This telephone fully supports all the CIX features and services of a regular IP5122-SD telephone. However, this telephone can have a unique feature button called the Analog Central Office (ACO) button to connect directly to your local Central Office. This ACO feature enables you to make Emergency 911 calls and/or calls on your direct CO line by bypassing your Strata CIX system. Power over Ethernet (POE) or AC power is required for the telephone's analog local line connection to operate.
- **IP5132-SD** – 20-button IP speakerphone with 4-line x 24-character backlit LCD
- **IP5131-SDL** – 20-button IP speakerphone with 9-line x 24-character backlit LCD and HTML interface with navigation key. This telephone has 18 Soft Keys located on the sides of the large LCD to respond to the Strata CIX feature prompts, ten of these are programmable feature buttons. The Shift key (Purple key) toggles the LCD screen between flexible keys 1~10 and flexible keys 11~20.

**IP5022-SD**

10 programmable buttons, 4-line LCD

**IP5122-SD & IP5122-SDC**

10 programmable buttons, 4-line backlit LCD

**IP5132-SD**

20 programmable buttons, 4-line backlit LCD



**IP5131-SDL**

20 programmable buttons, large backlit LCD with HTML support and navigation key



## Features

The IP5000-series telephones include a speakerphone and are 802.3af standard compliant for Power-Over-Ethernet (PoE). The IP Telephony product family also includes matching Add-On Module and a DSS Console.

The IP5000-series telephones support a very comprehensive and powerful feature set including:

- Backlit Displays (except IP5022-SD)
- Gigabit Ethernet Switch
- Analog Central Office (ACO) button (IP5122-SDC only)
- Busy Lamp Field (BLF) display of station status.
- Background Music through telephone speakers.
- Paging over telephone speakers.
- IPT Anywhere
- Automatic Configuration
- Terminal Authentication (security)
- Off-hook Call Announce (OCA) over telephone handset.
- Speaker OCA when using MIPU / LIPU / LIPS, GIPU or GIPH.

**Note** IP5000-series telephones enabled with Speaker OCA require two IP channels from the same IP interface card but only one end point license. The IP channel used for Speaker OCA is only used during the OCA call and may be shared by all IP5000-series telephones.

- Built-in headset interface for headsets and external speaker connection (BESCB)
- IP Add-on Modules

In addition, the 5000-series IP telephones contain several important features, including:

- Full-duplex speakerphone capability when using an MIPU / LIPU interface card in a CIX system.
- 802.3af power over Ethernet compliant
- Integrated Application Processor for Voice Mail, Unified Messaging ACD, and other applications
- Soft Keys to respond to the Strata CIX feature prompts.
- Additional feature adjustments, such as setting button beeps, room noise sensitivity and handset busy override tone.
- An adjustable tilt stand base is built-in, providing flexible angle adjustment of the entire telephone.

## IP Protocol

The Strata CIX uses RFC3015 Media Gateway Control (MEGACO) enabling Strata systems to provide all the feature functionality of digital-series telephones to IP telephone users.

## Connectivity

IP telephones connect to either the MIPU, LIPU, LIPS, GIPU or GIPH in the Strata CIX system running software version 5.2 or above. However, the IPT2008-SDL can only be connected to the MIPU, LIPU/LIPS GIPU or GIPH. These telephones must be connected to MIPU / LIPU / LIPS, GIPU or GIPH to use peer-to-peer Real Time Protocol (RTP) connection.

**Note** The Strata CIX also supports the IPT1020-SD. This telephone can be connected to a BIPU-M card only. It does not support peer-to-peer RTP connection.

- These telephones do not use the System power supply, so there is no power restriction to limit the number of IP telephones that can connect to an individual Strata system. The IP Telephones have built-in connectors. The back of the telephone has connector labels. The telephones can be powered by a local power supply on the PoE (Power over Ethernet).
- The RJ45 LAN jack connects the telephone to the network via the LAN cable supplied with the telephone. These telephones operate on the network at 10/100Mbps and 1000Mbps(IP5000-series only) and can be connected to a fast switch hub, router, LAN, WAN, etc.
- The RJ45 PC jack can connect the IPTs to the user's PC. The IPTs can operate like a switch, as opposed to a hub, so the telephone can be connected directly to the LAN or Cable/DSL modem, and then a PC can be connected to the telephone PC jack to connect to the LAN through the telephone.
- The built-in headset jack enables headsets to be connected to the telephone. No optional headset interface is required. The same carbon or ECM headset support used on Toshiba digital telephones can also be used on IP telephones.

## Capabilities

The Toshiba IP Telephones also have the following capabilities:

- The IPTs contain two types of codecs (coder/decoder): G.711 and G.729A. The codec determines the IP telephone voice quality and network bandwidth requirements. The G.711 requires the most bandwidth and provides the best voice quality. The G.729A requires less bandwidth, but it does not provide the best voice quality. The desired codec is selectable for each IP telephone in IP station administration using eManager or Network eManager.
- The external ringer interface connector is mounted inside the telephone base. This enables connection of an BESC external speaker device to provide a loud ringer for the IP telephone.
- All telephones in the system can be IP telephones up to the system's maximum station capacity (see [Table 51 on page 177](#)).
- Terminal Authentication is an option that allows a particular IP telephone to keep a reserved directory number on a CIX system. This prevents IP telephones from logging in with another telephone's directory number if the other telephone has been disconnected to be taken to another location. This feature uses the unique Media Access Control (MAC) address that is permanently coded into each telephone network interface circuit. The unique MAC address of the telephone is assigned to a particular directory number in system programming.
- IPT firmware can be updated locally or remotely using eManager. This enables service personnel to update IP equipment with new features and enhancements as they become available. Updates require a brief interruption of IP telephone operation (a few minutes).
- IP telephones have a discovery retry timer to prevent network congestion when many IP telephones request services simultaneously. If network congestion is detected, the telephone will pause and then retry for service.
- IP telephones have loop back and ping capabilities for maintenance and fault finding purposes.
- IP telephones support Dynamic Host Configuration Protocol (DHCP) or static IP addressing.

## Liquid Crystal Display (LCD) Models

The IP5022-SD, IP5122-SD, IP5122-SDC and IP5132-SD models display up to 24 characters times four lines of information and provide four Soft Keys.

The IP5131-SDL has 4 soft keys and a 9-line LCD. From the idle screen you can access telephone directories and speed dial lists of names or departments, internal or external to the telephone system. You can search by name or letter within a list.

The IP5131-SDL screen consists of Phone, Config, and Web-application screens. The screens change easily by pressing the tab soft key.

- Phone screen – This screen is a 150 x 168 pixel LCD screen.
- Config screen – This screen can be used for Telephone configuration settings. Using this screen, you can set the IP address, subnet mask, etc.
- Web screen – provides users with the access to the web page. This capability can be used to create the custom applications designed to match with IP5131-SDL phone screen so that the user can enter or retrieve the data from the IP5131-SDL phone.

All LCD telephone models can provide:

- Advisory Messages
- Automatic Number Identification (ANI)
- Caller ID, Name and Number with call history
- Contrast adjustment (13 levels)
- Backlight adjustment, except IP5022-SD (On/Off/Synchronized)
- Date/Time of Day
- Dialed Number Identification Service (DNIS Name and Number)
- Feature Prompting Soft Keys that are used as an alternative to access codes or feature buttons. Station users can access features by responding to LCD prompts.
- Called Number displays on outgoing calls (1~120 secs.)

# Telephone Button Expansion Options

Upgrade options for the Toshiba IP telephones are described below.

## LCD Add-on Module (LM5110)

The LM5110 adds 10 programmable LCD feature buttons to the 5000-series telephones, these buttons can be assigned as CO line, Directory Number, DSS, One Touch, Speed Dial or any other flexible feature.

The LM5110 supports backlight and LCD labels, it can be connected to any 5000-series telephone (except DP5008).



## Key Module (KM5020)

The KM5020 adds 20 programmable feature buttons to the 5000-series telephones. These buttons can be assigned as CO line, Directory Number, DSS, One Touch, Speed Dial or any other flexible feature.



## IP Direct Station Selection (IDM5060) Console

The IDM5060 console (shown right) is for system attendants.

The IDM5060 operates alongside a IP telephone and has 60 programmable feature buttons. These buttons can be assigned as CO Line, Directory Number, DSS, One Touch, Speed Dial or any other flexible feature.

Up to three consoles can operate with one IP telephone depending on CIX system.

The IDM5060 console uses LEDs to indicate call and feature status; the DSS has dual red and green LEDs to help further define status, such as station in DND status. The IDM5060 console connects directly to an IP5000-series station.



## CIX Attendant Console

The Strata CIX Attendant Console runs on a PC with Microsoft® Windows® 2000 Professional or Windows XP Professional operating system. The Strata CIX Attendant Console PC is equipped with an Intel two gigahertz CPU in a small, compact desktop chassis that is just the right size for a receptionist's desk. If there isn't any room on the desk for the system to lay flat, it can also be stood on its side for an even smaller footprint. Add to that the powerful Strata CIX Attendant Console software, and you have a winning solution for any Strata CIX installation!

The Console connects to the Strata CIX processor via the LAN as a Computer Supported Telephony Application (CSTA). The Strata CIX system requires the processor NIC interface.

Each CIX Attendant console requires the LIC-ATT license which is bundled with the Toshiba supplied Attendant Console PCs and software. The LIC-ATT license must be ordered separately to enable the Console to be installed on a Dealer / Customer supplied PC. The latest Attendant Console software is available at no charge on Toshiba FYI.

The minimum PC requirements for the CIX Attendant Console are:

- Operating Software – Microsoft Windows XP Pro or Windows 2000 Pro
- Processor – 2.0GHz Intel Pentium 4, Celeron or higher
- Memory – 512M RAM
- CD-ROM Drive, CD-R/W Drive or DVD capable of reading CD-ROM data files to install Attendant Console software.
- Hard Drive: 500M space available
- Sound card with internal or external speakers

There are two types of CIX Attendant Consoles; each operates and functions the same but each provides a different type of talk-path.

The following Attendant Console hardware is available from Toshiba:

- CIX-DATTCONS – provides a digit talk path like a digital telephone and requires a BDKU interface port. Includes software and LIC-ATT license.
- CIX-IPATTCONS – provides an IP talk path like IP telephones and requires an MIPU / LIPU interface port. Includes software and LIC-ATT license.

Each of the above CIX Attendant Consoles consists of the following *standard* items:

- Attendant Console License (LIC-ATT) for the CIX processor (bundled with Toshiba Console part number)
- LIC-ATT must be ordered separately if using a Dealer supplied PC for the Attendant Console
- Intel 2.8 GHz CPU
- 512M Random Access Memory (RAM)
- CD R/W drive
- Windows 2000 Professional (factory installed)
- CIX Attendant Console software (factory installed)
- Comprehensive set of multimedia inputs and outputs
- Keyboard & Mouse
- PC Headset (CIX-IPATTCONS only)
- Attendant Keyboard stickers (Black) CIX-BL-ATCON-VA



The *optional* items are:

- Printed documentation is available on Toshiba FYI, as well as Documentation downloads.
- 17" Flat screen Monitor – Toshiba offers a 17" Liquid Crystal Display (LCD) flat screen monitor; part number CTX-LCD-MONITOR.
- Attendant Console Interface Unit (BATI) and Handset/Cradle (BATHC) connects to a digital telephone interface port on the Strata CIX (CIX-DATTCONS only). An optional headset can be used in conjunction with the handset.

...or

a DKT3001 or DP5008 can be used as the console handset instead of the BATI/BATHC handset/cradle. If an optional headset is used, it connects to the optional BHEU installed in the DKT3001 or directly into the DP5008 built-in headset jack (CIX-DATTCONS only).

### **Important!**

- *If a digital telephone is used in place of the BATI/Handset, it can be used as the Attendant Console Handset only. It cannot be used as a telephone to make or receive calls independent of the console. This includes when the console is in service or out of service.*

The Strata CIX1200 supports up to six, the CIX670 system supports up to four, and the CIX200, CIX100 and CIX40 supports up to two Attendant Consoles. Multiple consoles automatically share the incoming call load on a call-by-call rotation basis. Features such as Overflow and Position Busy add to the efficiency of single or multiple console applications.

The CIX Attendant Console is designed to handle all call activity within a single Call Monitor screen, shown below. All calls will appear in a single list.

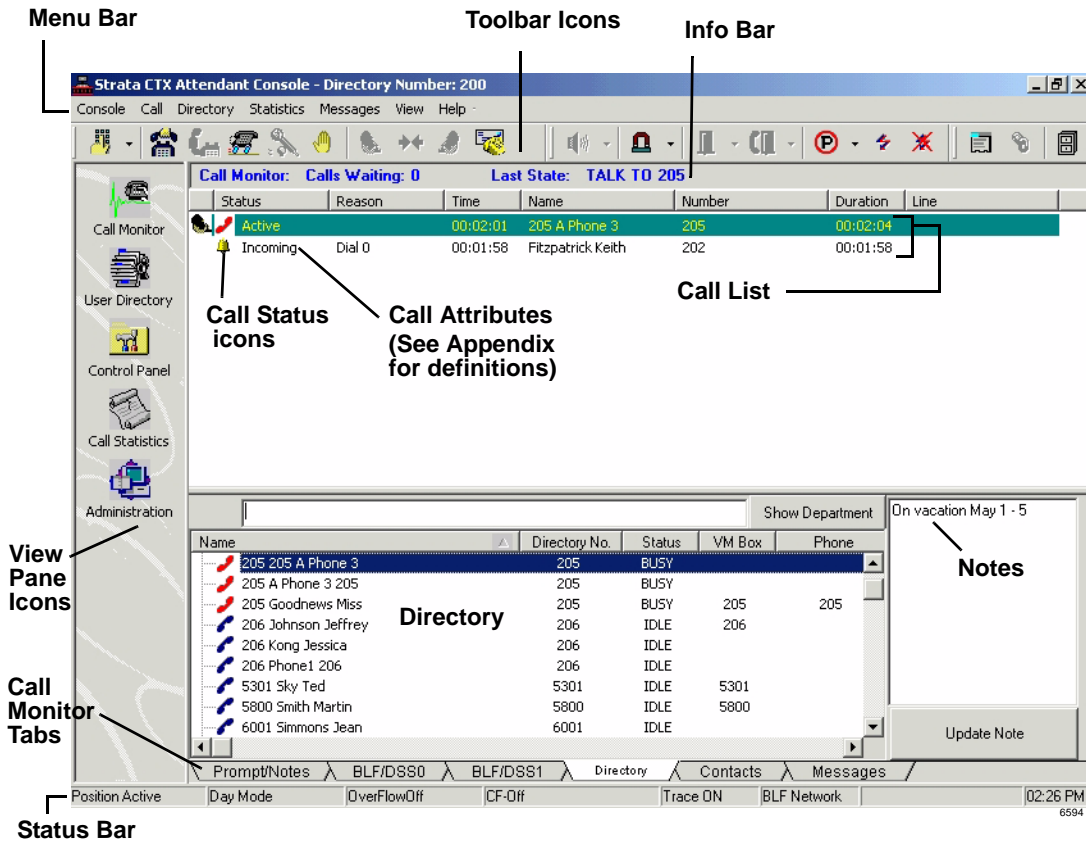

Calls are marked with icons to show the current status.

Features such as Paging, Call Pickup, Call Park offer many alternatives. The Administration window enables which option is the primary operation for that Attendant. For example, if two zones are used for paging, as well as the All Call, then an option pull down arrow is next to the icon. Clicking the icon starts the All Call Page, then the Attendant can select one of two page zones.

All other views available for the Attendant are for administrative and management use. They do not control any type of call handling except how chosen options affect the overall operation.

The CIX Attendant Console also enables an attendant to manage console settings, maintain a user directory, and view call statistics. The Console provides a Name/Number search that works with automatic or manual call handling. Other features include Queuing, DSS, signaling, Emergency Call ID, keyboard or mouse operation, and headset or handset operation with volume control.

## Peripherals

The Strata CIX supports several types of stations and customer-supplied peripheral devices, such as door phones for visitor screening, a music source interface for MOH and BGM, a speaker for amplified ringer, Toshiba Voice Processing systems for voice mail/auto attendant applications, and more.

Toshiba Telecommunication Systems Division (TSD) does not provide ISDN or IP station equipment, such as ISDN IP telephones, fax machines, and computer interface devices for high speed Internet access or video conferencing. Toshiba does provide the interface circuit boards that support all of the above ISDN station equipment.

### Door Phone (MDFB)

Door phones can be assigned to ring telephones when the button on the door phone is pressed. The Door Phone location displays on the called telephone's LCD. When the telephone answers, a two-way talk path exists between the telephone and door phone.

Door phones can also be used as sound monitors. Station users can call the door phone (it will not ring) and listen to sounds from the surrounding area. Door phones also can operate as a "hot line." For example, a door phone can be used for calls between an office and a warehouse. Door Phones are often used with a door lock to screen building visitors. The door lock can be opened for a predetermined amount of time by pressing a button on a telephone.



1873

### Door Phone/Lock Control Unit (DDCB)

The DDCB can support as many as three door phones (MDFBs) or two door phones (MDFBs) and one door lock control relay. Using the door lock control, digital station users can unlock a customer-supplied electronic door lock at the touch of a button programmed on their digital telephone or by dialing a feature access code from any type of telephone. Each DDCB requires one digital station circuit.

Each door lock can be programmed to remain open between three~30 seconds. The Door Lock button LED remains On while the lock is open. LCD telephones display "DOOR UNLOCKED" until the telephone releases or times out.



1874

### External Speaker (BESCB)

The BESCB is a multi-functional, external, speaker control box with a built-in three-watt amplifier. It can be used to control and drive a paging speaker, a paging amplifier, or a telephone's Loud Ringer.

## Mobility Solutions

Toshiba mobility solutions maximize the value of the customer's wireless Local Area Network (WLAN) by using their existing WLAN infrastructure. This makes very cost-effective mobility solutions possible with Strata CIX solutions.

### SoftIPT

For more details, see [“Toshiba SoftIPT IP Telephone”](#) on page 126.



SoftIPT for Laptop/Tablet

SoftIPT for PDA

### Wireless Access Points

Toshiba has a strategic relationship with SMC Networks, a leading provider of networking solutions for the small and medium business markets to market a host of SMC Networks wired and wireless networking products through authorized Toshiba dealers. As part of providing a total solution, you can purchase SMC wireless access points from Toshiba and package them with Strata CIX solutions.

Toshiba supports the SMC EliteConnect 2.4GHz Wireless Access Point. This access point sized and priced to fit well with Strata CIX systems to serve wireless LAN applications in which customers want to install new or expand the capabilities of their existing wireless LAN.

Features and specifications:

- IEEE 802.11b and 802.11g compliant
- Data rates up to 54 Mbps in 802.11g, and 11 Mbps in 802.11b with auto-fallback feature
- High configurable transmit power up to 100mW
- Support up to 64 users
- Enterprise level of authentication and encryption security
- Flexible management features including Command Line Interface (CLI), Web-based management, SNMP, Syslog, and Event Logging
- Detachable antennas for optional external 2.4GHz high gain antenna
- Power over Ethernet
- Anti-theft mechanism



SMC EliteConnect 2.4 GHz  
802.11g Wireless Access Point  
(SMC2552W-G)

## VPN/Firewall Solutions from SonicWALL

Toshiba has a strategic relationship with SonicWALL, one of our industry's leading suppliers of network security firewall products, to re-sell the SonicWALL Pro series of firewall products through authorized Toshiba dealers. As part of providing a total solution, you can purchase firewall products from Toshiba to create tightly intergrated converged voice and data solutions using the Strata CIX.

The Pro 2040 is SonicWALL's new entry model into the high-performance PRO appliance series for small configurations, typically up to 150 users. The PRO 2040 is tailored for small to medium-sized businesses requiring a high level of security performance and features, but still requiring ease-of-use and an affordable price.

Features and specifications:

- 200Mbps Firewall, 50Mbps VPN.
- Up to 4 10/100 Base-T Ports.
- Hardened Platform with Redundant Fans.
- 150 Total VPN Tunnels.
- Intrusion Prevention Services
- VoIP Support
- Enhanced Load Balancing, Fail-over.
- Enhanced Deployment Flexibility.
- Enhanced NAT Modes.

The TZ-170 (shown right) is SonicWALL's solution for firewall and VPN capability for remote and branch offices. The TZ-170 provides the same features and administration interface as the larger 2040, but at the right size for smaller sites.

- 10, 25 and unlimited user configurations
- 90 Mbps Firewall
- Up to 10 VPN tunnels
- Seven Ethernet ports
- Intrusion Prevention Services
- VoIP support



Pro 2040

7868



TZ-170

7869

## Power-Over-Ethernet Solutions from SMC

Toshiba has a strategic relationship with SMC to re-sell the 24-port, 802.3af certified SMC6824MPE PoE switch through authorized Toshiba dealers.

The SMC6824MPE PoE switch is sized and priced to fit well with Strata CIX systems to serve applications in which customers want to power their IP telephones over Ethernet, instead of using local power with each IP telephone.



SMC3526-PoE

# Video Communication Solution

The Strata Video Communication Solution (VCS™) is designed to provide Strata users with an integrated collaboration tool, including point-to-point 8-party video conference, 3-party collaboration (desktop and applications sharing), 8-party file transfer, and 3-party message board capabilities to make video communication and collaboration more powerful than ever!

VCS has many Graphical User Interface (GUI) enhancements. It provides a more valuable and complete Strata IP solution. QoS is included and the GUI on VCSManager has changed to make configuration and VCS setup more intuitive.

## Visual Collaboration

8-party conferencing with 3-party Video conferencing takes productivity to a new level. While a total of eight parties are on a call, three parties can also see, hear, interact and collaborate on projects together, no matter where they are physically located. VCS provides a way to conduct remote virtual meetings, work group discussions, and much more.

During the voice conference, any of the three parties can initiate application sharing, edit a file, send and receive files, and send text to a message board. These great tools will dramatically increase productivity and quality of work, while reducing the cost of business travel.

## Try VCS for FREE

Strata CIX/MAS customers can also enjoy VCS FREE with the 90-day trial license.

Just order and activate the trial license on your MAS to try VCS. After the free trial period expires, VCS permanent licenses can be purchased. The MAS requires a memory upgrade to 1GB to support VCS.

## VCS Features

Combined with all the features in VCS 2.0, and enhanced to support up to 8-party VCS user applications, VCS 3.0 is an attractive voice conferencing, video conferencing, and collaboration solution for today's demanding Strata customers.

The following are highlights of features available in VCS 3.0.

- **Fully integrated with the Strata CIX system** – VCS Server software is pre-installed on the Strata Media Application Server (MAS). VCS Windows XP client software easily extends the Strata CIX voice user's multi-media experience.
- **Point-to-Point 3-party Video Conferencing** – A cost effective solution, multi-party video conferencing is achieved without any additional hardware. VCS runs as an application on the MAS. Various window layouts and options are available for customization. Automatic interface makes video conferencing easy to use and easy to manage. In a conference with more than three parties, any three parties can be selected to have the video.
- **8 way Collaboration** – Desktop, application, and document can be shared by up to 8 VCS users. All users can edit the same materials while in session (one editing at a time).
- **Session Member List (SML)** – Displays VCS members who are logged on and have established voice communication with you. You can easily select members from this list to begin any VCS collaborative sessions.
- **8 way File Transfer** – Users can send and receive multiple files to other VCS users.

- **8 way Message Board (Chat)** – Users can post text and chat on a message board, as an alternative to communicating verbally.
- **Support for QoS** – If the customer’s network equipment is end to end, Diffserv Priority control can be enabled for all the clients from VCSManager. This system setting will give Video, Collaboration and File Transfer media a higher priority.
- **Video Setting Control** – Similar to QoS setting, VCS administrator can control the upper limit of video bandwidth via VCSManager for all VCS clients.

VCS functionality is integrated with the Strata CIX telephony capabilities, with features specifically tailored to handle video telephony, including:

- Call Hold/Retrieve
- Call Transfer
- Call Forward
- Station Hunting
- Call Park/Retrieve (Calls can be parked on the local node only.)
- Call Pickup/Retrieve
- Up to 3-way video with 8-way voice conference
- Manually select default Video Setting and Video display default On or Off
- Automatic Start VCS after Windows log on and Automatic VCS log on after VCS application started
- Self Video preview



## Software

VCS Server software is pre-installed on the Strata MAS with Windows XP Pro. Existing Strata CIX/MAS customers can also install VCS software on their MAS.

VCS Client software runs on each user’s Windows XP Home or Pro computer. Client software is provided together with VCS Server software on the Strata MAS.

## VCS Software Upgrade

VCS 3.0 is compatible with Strata CIX Release 5.0 or later systems.

- Older versions of Strata CIX must be upgraded to Release 5.0 before upgrading VCS software from version 1.0 to 2.0.
- VCS 2.0 software can upgrade to VCS 3.0 FREE of charge.

## Licenses

See [Chapter 8 – Strata Media Application Server and Integrated Voice Mail Cards, Table 19 on page 77](#) for VCS Licenses.

## Product Specifications

Item	Specification
Strata CIX	Release 5.0 or later Multiple Strata CIX nodes must be networked via Strata Net
Endpoints	Strata Digital Telephones, Strata IP Telephones and Soft Phones
VCS Client PC Requirements	CPU: PentiumM 1.5GHz or greater Memory: Minimum 512MB Free hard disk space: 10MB 100 Base - TX Network Interface Card Windows XP Home or Pro with SP1, SP2, SP3, Vista SP1 Direct X Version 9.0c or later (and compliant video graphics card)
Accessories	USB Camera: Recommend using Logitech QuickCam Pro 5000 or QuickCam for Notebooks Pro
VCS Server Hardware Requirement	MAS, 2U MAS or MicroMAS 1GB RAM Minimum Free hard disk space: 120MB
VCS System Capacities	VCS server can support: Max Number of CIX nodes (based on RAM): 9 (1GB) Number of configured users: Limit to available Disk space Maximum activated user licenses: 480 Maximum logged on users: 480 Maximum Number of VCS clients active sessions (stations): 480
Video	Standards: MPEG4 Output Format: VGA, QVGA, QCIF Encoding Bit Rate: 128kbps to 1.5Mbps Video Frame Rate: Auto adjust up to 30 fps
Protocols	Signaling: Client/Server – SIP RFC 3261 Networking: TCP/IP v4, FTP, HTTP Client: UPnP Server: CSTA
Administration	Web based VCSManager: VCS server information settings, CIX Profiles settings, User information settings, QoS settings, System Video Settings, Administrator information, VCS license activation, log files - to local disk or transfer log files using FTP, backup and restore system data, display operation status (User and Server status, Version information, maximum of user licenses purchased and number of active users logged on. Log file size: 450MB in HDD per CIX VCSManager manages one VCS server. One VCS server can handle multiple Strata CIX nodes.
Warranty	Software is "AS IS" without warranty of any kind.



# Toshiba Strata Voice Processing

The Strata CIX can operate with Toshiba Strata voice processing systems, which provide a number of helpful messaging and related features. The Strata CIX supports in-band DTMF voice mail integration and requires DTMF receivers. It also supports standard SMDI and Toshiba Proprietary voice mail integration. Refer to the appropriate Strata literature for details.

All Strata systems provide these essential applications:

- Automated Attendant to answer incoming calls without receptionist assistance
- Call Routing to direct callers to specific extensions or departments they want
- Telephone Answering to take messages when an employee is unavailable
- Voice Messaging to create, send, receive, forward, and save voice messages
- Audiotext to play pre-recorded information on demand
- Call Screening to announce the calling party
- Message Notification to let you know when messages are left
- Token Programming to customize your Strata voice processing functions

Strata gives you the ability to:

- Simplify voice mailbox operation through a Strata CIX telephone with LCD display and soft keys
- Record calls directly into your voice mailbox with a single button on your telephone
- Manage voice, fax, and e-mail messages from your PC or telephone via Unified Messaging
- Add advanced options as needed to support Fax Integration, Text-To-Speech, Speech Recognition, and Interactive Voice Response applications
- Communicate effectively both in and out of the office with other employees and customers 24 hours-a-day, 365 days-a-year

From basic to sophisticated, Toshiba Strata voice processing delivers a variety of voice mail choices to select what's best for your business.

Strata IVP8, iES16, and iES32 models seamlessly integrate your voice message processing on a single printed circuit card inside your Strata CIX system—with no need for external connections, standard telephone ports, or separate power backup systems.

Toshiba's Strata Media Application Server supports voice processing and all value-added applications integrated within one platform that connects to the Strata CIX via Ethernet. Applications include Auto Attendant, Voice Mail, Automated Speech Recognition (ASR), Text-to-Speech, Unified Messaging, Interactive Voice Response (IVR), Automatic Call Distribution (ACD), ACD Reporting, Toshiba-approved 3rd party CTI applications, Info Manager™ Web-based telephone applications, FeatureFlex adaptability tools, and browser-based system administration.

## Cabling and Connectors

The Strata CIX uses industry standard cabling and connectors to interface with lines, stations, and peripherals. Stations use standard twisted-pair cabling to connect to the system via the MDF. Digital and standard telephones require just one pair-cabling. Two pairs may be required to achieve full distance when optional DP subassemblies are used.

Digital telephones connected to BDKS require an external power supply to reach maximum distance from KSU when the telephone has a DADM or DOCA-1A.

Station circuit cards connect to stations and peripherals with a 25-pair Amphenol connector via the MDF. Analog CO, DID, and Tie line circuits interface with the public telephone network via modular connectors. T1 and ISDN use industry-standard Amphenol and modular connectors (for details, see [Table 36 on page 164](#)).

Peripheral devices such as eManager maintenance PCs, etc., connect to a hub or LAN, which connects to the processor's Ethernet LAN interface via an RJ45 connector and Category 5 wiring. Call Accounting and Voice Mail SMDI require RS-232 modular adapters and cords to connect to the processor BSIS interface.

# Strata Media Application Server and Integrated Voice Mail Cards

# 8

## Strata Media Application Server (MAS)

The MAS allows multiple applications to be combined on a single device. Applications include Auto Attendant, Voice Mail, Fax, Automated Speech Recognition, Text-to-Speech, Unified Messaging, Interactive Voice Response, Automatic Call Distribution and Reporting, Web browser-based Personal and System Administration, Web-based Telephone Applications, FeatureFlex adaptability tools, and third-party applications.

Because it reduces the need for multiple servers to support each application separately, Strata Media Application Server dramatically decreases the cost and complexity of deploying multiple applications.

- The Media Application Server uses Host Media Processing (HMP) technology from Dialogic.
- With HMP the MAS does not require expensive dedicated boards for voice processing resources. Instead, HMP uses the host CPU for media processing.
  - When both ACD and Strategy ES licensed and running on the same MAS, then HMP does require specific configurations; up to 16 HMP Voice Mail ports in addition to 16 HMP ACD announcement ports can be supported.
  - If ACD is installed on MAS without Strategy, up to 32 HMP announcement ports are available. All port expansion is done with simple software license upgrades.
  - If Strategy is installed on MAS without ACD, up to 32 HMP voice mail ports are available.

The Media Application Server comes in two hardware form factors:

- 2U rackmount platform
- Desktop computer (MicroMAS)

### 2U Rackmount Platform

The 2U platform (shown right) offers the full premium of features and applications in a robust rackmount platform. It is equipped with a Pentium IV 2.8 Ghz CPU that supports up to 32 ports of IP voice connectivity to the Strata CIX. The optional fax modem boards, required to support fax features in the 2U MAS, are available in 1, 4, and 8 port configurations. The 2U MAS can be equipped with up to two fax modem boards, for a maximum fax modem port capacity of 16.



The 2U MAS platform is also available in, factory equipped, RAID 1 or RAID 5 hard drive storage configurations.

### MicroMAS

For CIX customers that do not require large IP voice connectivity, yet desire the benefits of a device powering multiple applications, a smaller, more cost effective MAS hardware solution is available. Called MicroMAS (shown right), this platform is a small desktop computer equipped with all of the applications of a MAS solution up to a maximum IP voice connectivity of eight ports. This makes it a perfect multi-application solution for the Strata CIX40 and CIX100.



The MicroMAS itself comes in two configurations; HMP based and Dialogic hardware based. The HMP based solution, MicroMAS-H, provides VoIP connectivity to the CIX, whereas the Dialogic hardware based MicroMAS-D connects to a CIX by means of standard analog port interfaces.

MicroMAS also supports fax applications. The MicroMAS-H can be optionally equipped with two 1 port fax modem boards, connected to the CIX via analog ports, for a maximum capacity of 2 ports of fax.

The MicroMAS-D can be equipped with a maximum of two 4-port D/4PCIU-F Dialogic boards. Each of the 4 ports of this board can implement a soft fax application, allowing the MicroMAS-D to support up to 8 ports of voice or fax. If the MicroMAS-D is to support speech recognition applications, then a 4 port D/4PCIU-S board is required. This board cannot support fax, consequently fax and ASR applications are mutually exclusive from each other on a MicroMAS-D platform. MicroMAS-H can support both ASR and fax.

**Important!** *Whenever the MAS is mentioned in the remainder of this chapter, it applies to both the 2U MAS and MircoMAS, unless specified otherwise.*

### Standard Software Applications

The Strata Media Application Server comes standard with the following pre-installed applications:

- Stratagy Enterprise Server (ES) Auto Attendant/Voice mail with five Unified Messaging seats.
- eManager Web browser-based unified system administration and maintenance for installation technicians.
- My Phone Manager Web browser-based personal administration for individual end users and system administrators.
- Strata Automatic Call Distribution (ACD) application gives call centers the ability to determine how calls are best distributed to their ACD Agents.
- The Insight family of products are call center management software solutions that can be configured for businesses served by the Strata Business Telephone Systems and the ACD application. Insight may be purchased in many configurations to provide management solutions to both small, informal call centers requiring basic, single supervisor packages to large call centers requiring sophisticated, networked solutions. Each model is easily upgraded by entering new license codes which feature additional capabilities.
- TASKE Contact provides a suite of easy-to-use management tools that enable a contact center supervisor to manage their agents, set and meet service levels and provide vital management information on call activity. TASKE Contact is a robust management application that's easy to use and includes ACD Monitor with Replay feature, Reports, WallSign, myTASKE and Traffic Analyzer. TASKE Contact has several add-on modules to further enhance the application and includes Contact Desktop Sign, TASKE Enterprise Client and TASKE Work Force Management Interface.

**Note** Strata ACD, Insight, and TASKE Contact require licenses. Refer to CIX Quote for configurations and part numbers.

## Optional Software Applications

The Media Application Server is shipped with all standard and optional application software pre-loaded. The following optional software modules are also available with additional licensing:

- Strategy ES ports upgrades up to a maximum of 32 (on 2U MAS platform).
- Strategy ES Feature Groups (Automated Speech Recognition, Fax, Text-to-Speech, Unified Messaging, Interactive Voice Response).
- FeatureFlex
- Strata ACD and OAISYS modules (For details, refer to the *Strata CIX and CTX Call Center Solutions General Description*).
- Insight or TASKE ACD Reporting (For details, refer to the *Strata CIX and CTX Call Center Solutions General Description*).
- Video Communication Solution (VCS)

To activate optional software modules in the Media Application Server, product and service licenses are purchased and downloaded from FYI using the same process as for current Toshiba license-controlled products. The Fax Feature Group requires the purchase of fax modem boards that will be installed in the MAS chassis and connected to the CIX via analog interface circuits (e.g. BSLU). Fax modem boards are available in 1, 4, and 8 port configurations. MicroMAS-H can only be equipped with the 1-port fax modem boards.

The pre-loaded software should never need to be re-loaded on the Media Application Server, but in the event this becomes necessary, the MAS recovery CD-ROM set can be ordered from Internet FYI.

## Connection to the Strata CIX

The Media Application Server with HMP connects to the CIX using IP connections through a Network Switch. All of the feature communications and Voice Mail speech paths are carried by this ethernet connection. The Strata CIX must also be equipped with IP station boards for voice path assignment.

As described before, MicroMAS-D and the fax modem boards of the 2U MAS and MicroMAS H require analog ports from the Strata CIX. The fax modem boards come in 1, 4, and 8 port configurations. Depending the fax port capacity desired, from one to sixteen CIX analog circuits (e.g. BLSU) may be required.

The monitor, keyboard and mouse are customer supplied options. The MAS can be accessed via the network by using the Windows® XP Remote Desktop feature.

The CIX MIPU / LIPU / GIPU / GIPH card IP Address must be accessible by the MAS.

The MAS and CIX must be physically installed first. Mount the MAS in the rack. Insert the circuit cards into the CIX cabinets. Connect the IP cables. When all of the cables are connected, power up the system and proceed to the MAS configuration and programming.

## Preloaded Software

The MAS is shipped with the application software loaded. Product and service licenses are downloaded from FYI. Refer to the Toshiba *Strata CIX Programming Manual (Vol. 2)*.

The pre-loaded software should never need to be loaded. In the event this becomes necessary the MAS Recovery CD-ROM set, included with the server should be used.

**Important!** *Installation of any software not approved by Toshiba voids the warranty.*

## Windows XP Firewall Settings

The MAS runs on the Windows XP Professional operating system. Windows XP includes an Internet Connection Firewall (ICF). When installing the MAS, consider the configuration of the network and how the MAS will be accessed. Changes to the ICF may be required. Considerations include:

- Will the MAS be accessed using remote desktop or will a keyboard, monitor and mouse connected to the MAS be the only direct access?
- Will the MAS be addressable via the internet?

## MAS Configuration Requirements

The MAS is a platform for running real-time IP based multimedia applications. It must process each IP packet of a multimedia stream, each voice packet, within a fixed amount of time, generally 20 ms. It is imperative that the amount of processing required of the MAS in the worst case not exceed its capacity in terms of processor speed, cache size, or memory size.

To ensure that the capacity of the MAS is not exceeded, two steps must be taken.

- The number of real-time voice channels processed on the MAS must be limited. When licenses are generated FYI checks what is currently licensed on the MAS, what is being added, and checks to see that the maximum is not being exceeded. This information is also programmed into CIX Quote.
- No other applications or windows components should be loaded onto the MAS. Many applications can, all by themselves, exceed the ability of the MAS to meet its 20 ms response time requirement, other applications working together can also exceed it.

This document contains information about specific applications and configurations. As the product and market evolve, we will update this document. Please check back on FYI occasionally for the latest version of this document.

## Approved Third Party Application Software

The table below shows the only third party application software that should be installed on the MAS.

**Important!** *Installing any other applications will void the warranty, and tech support will not provide any support until the MAS has been brought back to a reliable configuration.*

**Table 15 Third Party Application Software**

Application	Configuration Notes
PC-cillin™ Internal Security 2005	Should not be run in batch mode when running any other applications.
Symantec's Norton Anti-Virus™ 2005	Script blocking option must be un-checked.
McAfee® Virusscan® 2005 Ver. 9.0	Script blocking option must be un-checked.
Zoom Modem Driver	Zoom™/Modem V.92 USB Mini.
Trend Micro and PC-cillin are registered trademarks of Trend Micro Inc. Norton Anti-Virus is a registered trademark of Symantec Corp. McAfee and Virusscan are registered trademarks of McAfee, Inc.	

## Maximum MAS Configurations

The tables below show the available part numbers for the features that can be licensed to run on the MAS, and the maximum number of each that can be supported. However, we recommend checking all configurations through CIX Quote.

The tables below have three columns showing maximum configurations, the first shows the constraints on a MAS configured with both SES and ACD. The second column shows the constraints on a system that is configured with only Voice Mail. The third column shows the constraints of a system that is only configured with ACD.

**Note** MAS licenses are required for all Strata CIX systems – CIX40, CIX100, CIX200, CIX670, and CIX1200.

**Table 16 Toshiba SES and Feature Flex - Maximum Number of Licenses Shown**

Feature	License	SES and ACD	Voice Mail Only	ACD Only
Alarm Clock Enable	LICMAS-FF-ACLK	1	1	0
Auto Speech Recognition Auto Attendant.	LICMASFGASRAA, LICMASUPASRAA-2	8	8	0
Call Monitor Enable	LICMAS-FF-CMON	1	1	0
Call Return Enable	LICMAS-FF-CRET	1	1	0
Call Screen Enable	LICMAS-FF-CSCR	1	1	0
Four Port Upgrade for Strategy ES on MAS <b>Note:</b> Four ports per license.	LICMAS4PORTUPG	4	5	0

**Table 16 Toshiba SES and Feature Flex - Maximum Number of Licenses Shown** *(continued)*

Two port upgrades for Strategy ES on MicroMAS-H	LICMAS-H-2P-UPG	2	4	0
Two port upgrades for Strategy ES on MicroMAS-D	LICMAS-D-2P-UPG	2	4	0
One Seat Unified Messaging Upgrade.	LICMAS-FG-UM, LICMASUM10SEATS, LICMASUM25SEATS, LICMASUM50SEATS, LICMASUMUNLIMT	Unlimited	Unlimited	0
Fax feature license (one per system)	LICMAS-FG-FAX	1	1	0
One Number Access Enable	LICMAS-FF-ONUM	1	1	0
Text-To-Speech Feature Group.	LICMASFGTTSETI	4	8	0

**Table 17 ACD - Maximum Number of Licenses Shown**

Feature	License	SES and ACD	Voice Mail Only	ACD Only
Advanced Partner Program ACD Demo SW - B	LICMAS-ACDBR	1	0	0
Advanced Partner Program ACD Demo SW - H	LICMAS-ACDHQ	1	0	0
OAISYS Call Router License for Strata ACD	LICMAS-CALLRUTR	1	0	1
OAISYS Chat Text Messaging License	LICMAS-CHATSEAT	360	0	360
OAISYS Diamond out-of-plan upgrade for MAS	LICMAS-SUP-OUT	999	0	999
OAISYS Diamond support for MAS	LICMAS-SUP-OAI	999	0	999
OAISYS IVR Option with Database Assistant	LICMAS-ACDIVR	1	0	1
OAISYS NetPhone and chat license for MAS	LICMAS-NETSEAT	360	0	360
OAISYS NetPhone server and client	LICMAS-NETPH	1	0	1
Strata ACD Basic ACD 20 agent add-on lic	LICMAS-BASADD20	17	0	17
Strata ACD Enhanced ACD 20 agent add-on	LICMAS-ENADD20	17	0	17
Strata ACD MAS license (10 basic agent,	LICMAS-ACDBA10	2	0	2
Strata ACD MAS license (20 basic agent,	LICMAS-ACDBA20	1	0	1
Strata ACD MAS license (20 enhanced agent	LICMAS-ACDEN20	1	0	1
Strata ACD upgrade to enhanced for MAS,	LICMAS-UPGENHD	1	0	1
Strata ACD upgrade to enhanced for MAS,	LICMAS-UPGADD20	17	0	17
VA port license with HMP license	LICMAS-ACDVA	15	0	31



**Table 18    Insight - Maximum Number of Licenses Shown**

<b>Feature</b>	<b>License</b>	<b>SES and ACD</b>	<b>Voice Mail Only</b>	<b>ACD Only</b>
Additional Supervisor license for Insight	LICMAS-INSITSUB	99	0	99
Insight upgrade to Plus for Strata ACD	LICMAS-INSITUPG	1	0	1
Insight license for MAS	LICMAS-INSIGHT	1	0	1
inView client license for fifty users	LICMAS-INVIEW50	8	0	8
inView client license for five users	LICMAS-INVIEW5	72	0	72
inView client license for forty users	LICMAS-INVIEW40	9	0	9
inView client license for one user	LICMAS-INVIEW1	360	0	360
inView client license for ten users	LICMAS-INVIEW10	36	0	36
inView client license for thirty users	LICMAS-INVIEW30	12	0	12
inView client license for twenty users	LICMAS-INVIEW20	18	0	18

**Table 19    Video Communication Solution**

<b>Part Number</b>	<b>Description</b>
LIC-VCSTRIAL	90 Day Trial license, 1 Server License and 480 User Licenses
LIC-VCSBASIC5	VCS Starter, 1 Server License, 5 User Licenses
LIC-VCSUSER1	1 User Licenses
LICVCSUSER10	10 User Licenses
LICVCSUSER20	20 User Licenses

## MAS Licensing

All feature and application licensing is activated by the use of eManager which is pre-loaded on the MAS and accessible from a remote PC running Windows Internet Explorer.

- ③ Manager Menu, click MAS Licensing. The screen below displays.

The screenshot shows the MAS Licensing interface. On the left is a navigation menu with options: eManager Profile, Options, Select CIX, MAS Licensing (selected), and Logout. The main content area is titled "MAS License Management" and displays a "License Container Directory" table.

Date/Time	Name	MAS Serial Number	Local Status
2004-09-10 09:23:12	MAS231Upgrade.xml	200407071317311111	Issued in Local MAS
2004-09-10 09:23:12	NewMASLicense.xml	200407071317311111	Remote MAS
2004-09-10 09:23:12	SampleMASLicenseContainer-WebFoot.xml	200407071317311111	Issued in Local MAS
2004-09-10 09:23:12	SampleMASLicenseContainer-WebFoot2.xml	200407071317311111	Issued in Local MAS
2004-09-10 09:23:12	Webfoot23Upgrade.xml	200407071317311111	Issued in Local MAS

The example above shows a system with licensing already activated. The first time the license folder is viewed it will be empty. The following columns are shown:

- Generation Time – date and time assigned by the FYI application when it creates the container file.
- File Name – specified by the administrator when the container file was created in eManager using the Upload button.
- MAS Serial Number – defined in the header of the container file.
- Local Status
  - Local MAS – The MAC address in this container file is the same as the local MAS host MAC address (where the eManager server is running).
  - Issued in Local MAS – Same as “Local MAS” but the licenses in this container have been issued already. eManager stores a log of the issued container files.
  - Remote MAS – The MAC address in this container file is different than the local MAS host MAC address (where the eManager server is running). This file could be viewed, uploaded to other MAS, but it cannot be issued in the local MAS host.

## MAS Recovery

In the event that MAS suffers a catastrophic failure the Recovery CD-ROM's included with every system will restore the MAS to the configuration it was in when shipped. If possible backup the data, configuration and license files before starting.

**Important!** *The MAS Recovery procedure MUST be followed completely. Do not stop until the procedure is complete.*

## MAS Software Backup

The files on the MAS should be backed up on a regular basis. The backup files can be stored on a network disk drive or another network device.

A Backup and Restore Utility is available for managing customer database information for all of the applications on the MAS. This utility is available for download, at no charge, on the Toshiba FYI website. Product Bulletin PBCIX-0031 describing this utility and how to use it is also available on the FYI website.

## MAS Modem (Optional)

The MAS can be accessed from a remote location via the network by using the Windows® XP Remote Desktop feature. The MAS can also be accessed via a dial-up connection after the installation of the Zoom 3090 USB V.92 Modem (Toshiba part number SYS-USB-MODEM).

The Zoom™/Modem V.92 USB Mini is a compact external modem for Windows computers.



Physical Size	2.75 in. x 5.0 in. x 0.87 in. (7.0 cm x 12.7 cm x 2.21 cm)
Power	USB port powered no batteries or AC adapters are required
Interface Cables	Modem to MAS: USB cable (included) Modem to phone circuit: RJ-11 (NOT included)
Regulatory Approvals	FCC Parts 15B and 68 UL, C-UL, CE

Zoom is a registered trademark of Zoom Telephonics, Inc.

# Input Power

The MAS is supplied with a standard 15 Amp power cord with a standard three-prong 120 VAC that plugs into an AC power outlet. The MAS requires:

- A dedicated, properly grounded circuit

**Note** No additional grounding is required provided the AC outlet is properly grounded.

- An input power source of 120 VAC, 50 or 60 Hz, 5.67 amps (max)

## Power Failure Backup

Customer-supplied commercially available UPS systems should be used for power failure backup.

## Grounding

The MAS does not need any additional grounding provided the AC outlet is properly grounded.

## Connection

The MAS connects to the CIX using IP connections. All of the feature communications and Voice Mail speech paths are carried by these connections.

The monitor, keyboard and mouse are customer-supplied options. The MAS can be accessed via the network by using the Windows® XP Remote Desktop feature.

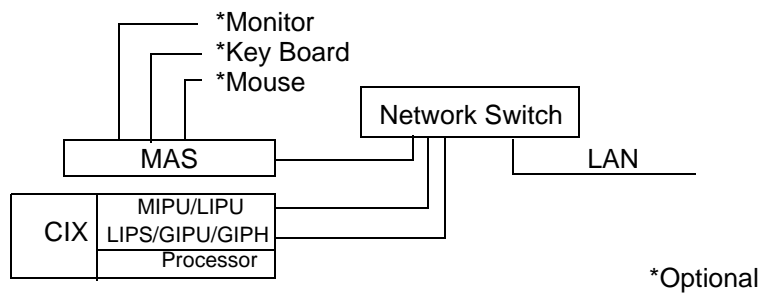

Figure 18 MAS Connection Block Diagram

# Physical Specifications

The MAS can be mounted in a two post rack or it can be mounted on sliding rails in a four post rack.

## Basic MAS Specifications

Dimensions of Cabinet	Height: 3.5 inches (86 mm)
	Width: 17 inches (430 mm) with bracket: 19 inches (483 mm)
	Depth: 18 inches (457.5 mm)
Cabinet Weight	Approximately 30 lbs. (13.6 kg)
Installation Type	Rack-mountable only. Cannot be floor or wall mounted.

### Two Post Rack Mount

Use four screws to secure the MAS in a standard 19 inch rack. The rack and other equipment must not block the air-flow at the back and front of the MAS. The rail kit is not intended for use in a two post rack.

### Four Post Rack Mount (Recommended)

The MAS can be mounted in a standard 19 inch four post rack or server cabinet. The rack and other equipment must not block the air-flow at the back and front of the MAS.

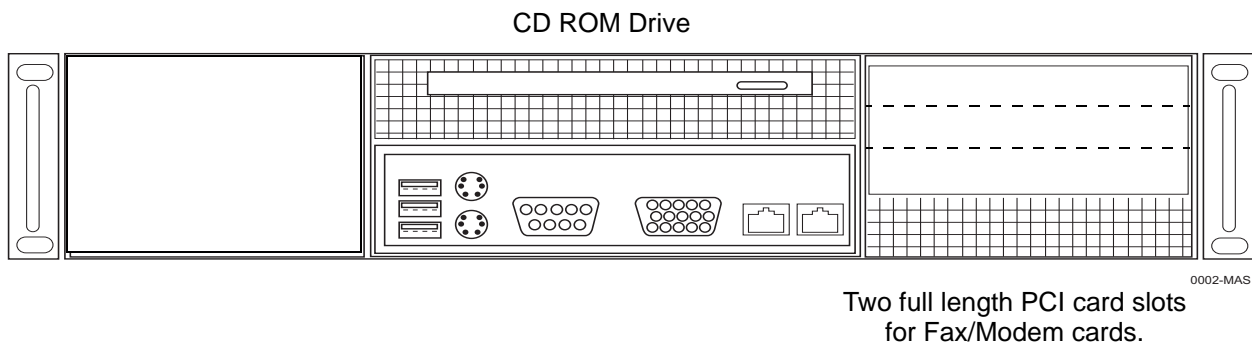

Figure 19 MAS Front View

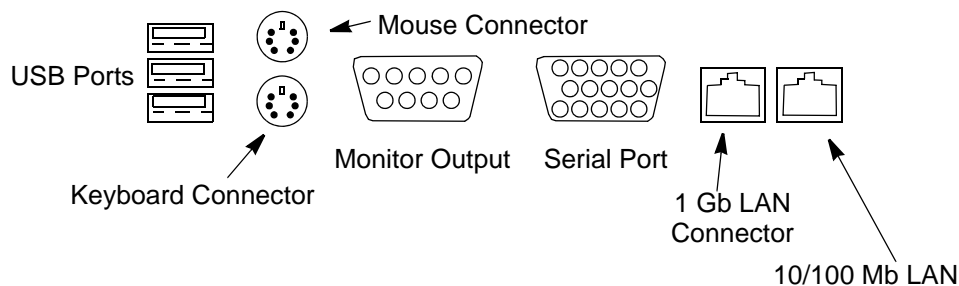

Figure 20 MAS Connector Detail

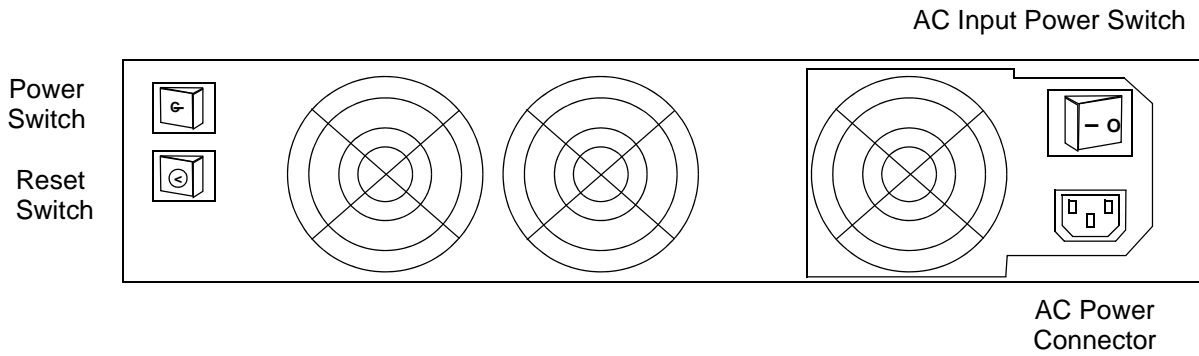

Figure 21 MAS Rear Panel

## MicromAS

Table 20 MicroMAS Basic Specifications

<b>Physical</b>	Dimensions (W x H x D)	12.17" x 3.3" x 12.8" (309 x 84 x 325 mm)
	Weight	15 lbs. (6.81 Kg)
<b>Environmental Conditions</b>	Operating Temperature	32°F~104°F (0°C~40°C)
	Storage Temperature	-40°F~140°F (-40°C~60°C)
	Operating Humidity	10%~95% (non-condensing)
<b>Electrical Requirements (AC Input)</b>	System 1	115VAC, at 6 amps (50/60 Hz) – standard 230VAC at 3.5 amps (50/60 Hz)– switch configured
	Provide host system with 15A circuit breaker and dedicated circuit.	

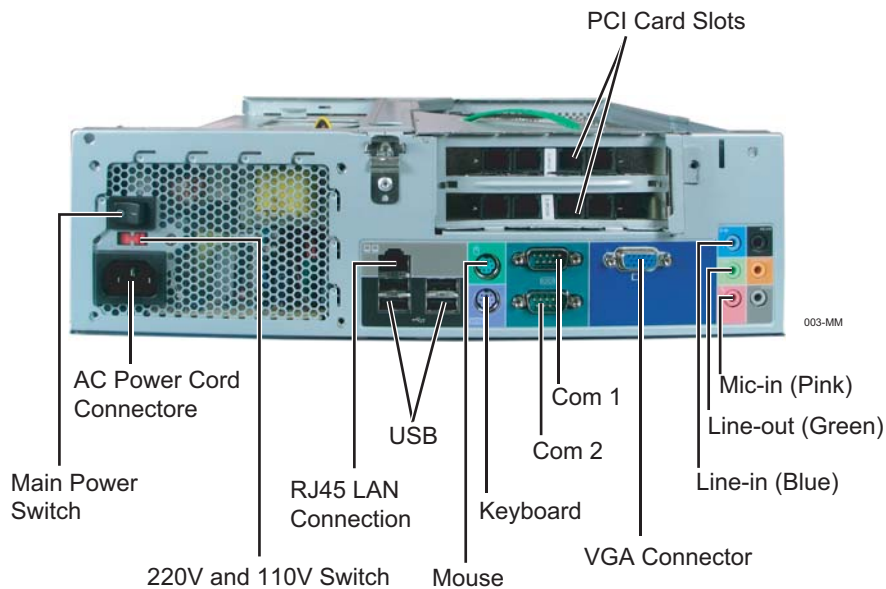

Figure 22 MicroMAS back panel

## Unified System Administration

### eManager® or Network eManager unifies Strata CIX and Stratagy ES System Administration

eManager, Toshiba's system administration tool, unifies the programming of both the Strata CIX telephony features and the Stratagy ES Voice Processing features of the system.

- eManager combines administration and management of the two previously separate applications, telephone system and voice mail into combined menus, allowing technicians and system administrators to program both together, and eliminate many duplicate steps.
- Some new wizards are added to support setup on integrated screens.
- New User Profile is designed to record equipment, user privileges, and authenticate the users during login. The User Profile allows organizing the equipment into domain groups of networked systems and presenting them in a tree. The user can select on the tree which equipment they want to access for administration.

eManager is a Web browser-based application that resides on the Strata Media Application Server. The eManager application can also be loaded on a separate server connected to the CIX network if the customer prefers.

eManager can be accessed locally over the LAN or, with proper network security, remotely over the Internet, and because it is used from the user's Web browser, no special software is required to be loaded on the user's client PC. The Web browser must be Windows Internet Explorer 6.0 or above. (Note: At this time eManager does not support other Web browsers).

### Network eManager

The Network eManager application reduces the time required to manage multiple Strata CIX equipment sites. While eManager can manage one CIX system during one administration session, Network eManager can manage a group of CIX systems in a single session. The possible situations when an administrator may need to configure multiple CIX systems as a group include:

- Multiple CIX systems in a Strata NET configuration.
- Setting up several CIX systems, at different sites, through the dealership LAN at the same time.
- Several sites, at different geographical locations, each with its own CIX, all managed centrally over a WAN.

The following are the benefits of using Network eManager over eManager:

To manage multiple CIX sites, the eManager user has to switch between CIX system sites by navigating back to a connection page. This closes the currently open pages, disconnects from the CIX system, and cleans all data collected from the eManager application. Once back on the connection page, the user selects the next single CIX and begins managing that system.

With Network eManager, the user selects an Equipment Group from a tree view. An Equipment Group can include any number of CIX systems and associated Stratagy Enterprise Servers (SES). Once an Equipment Group is selected, the user can connect to all members in the selected group. After a successful connection, Network eManager navigates to a menu with all of the member CIX systems of the connected Equipment Group available as destinations. The user can manage all member CIX systems of the selected Equipment Group without navigating back to the selection page. Compared to eManager, the features in Network eManager provide the following ways for managing multiple CIX systems more efficiently:

- Instant selection of a group member CIX system added to existing eManager pages. These pages target one CIX system at a time, but the instant selection control allows switching systems without closing the current page and navigating back to the connection page.
- The user can apply changes or extend operations to all group member CIX systems at once.
- A clipboard-like feature in Network eManager allows the user to copy and paste contents on the same page selectively.
- Some of the Network eManager pages and functions are designed to make managing Strata Net sites easier and faster. These functions operate across the member Strata CIX systems in an Equipment Group.

The Strata Synch utility in conjunction with Network eManager provides the interface between Microsoft® Active Directory Services (ADS) databases and the Strata CIX systems and Strategy ES voice mail systems. The Strata Synch utility decreases the programming time in new installations by eliminating the need for dealer technicians to manually create users in Network eManager and then create a corresponding voice mail box for each user. This utility can be used for ongoing maintenance. Changes made to the ADS database (user deletion, name change, extension change) can be propagated to the Strata CIX by simply re-running the Strata Synch tool and importing the database file into the CIX via Network eManager. The Strata Synch tool is a one-way synchronization tool. Changes made to the Strata CIX (user deletion, name change, extension change) will not update the ADS database.

## **My Phone Manager Gives Telephone Programming to Individual End-Users**

Toshiba's new personal administration tool, My Phone Manager, puts telephone personalization in the hands of individual users, allowing them to easily program speed dial buttons, feature buttons, Do Not Disturb functions, and even the name on their LCD displays, using their PC's Web browser.

- Administrator support is reduced because individual station users can program their own telephones themselves.
- With My Phone Manager, every person within the organization can customize their telephone to incorporate the features they use the most.
- My Phone Manager is also very useful to system administrators, who can administer changes for groups of users.

My Phone Manager is a Web browser-based application that resides on the Strata Media Application Server. The My Phone Manager application can also be loaded on a separate server connected to the CIX network if the customer prefers.

My Phone Manager can be accessed locally over the LAN or with proper network security remotely over the Internet, and because it is used from the user's Web browser, no special software is required to be loaded on the user's client PC. The Web browser must be Windows Internet Explorer 5.5 or above. At this time My Phone Manager does not support other Web browsers.



## All Features to All Users No Matter Where They Are

The Strata CIX delivers virtually every feature to every user, regardless of the type of device they are using, whether they are stationary or mobile.

- The system supports IP phones, wireless IP telephones, both analog and digital telephones, IP softphones on laptops, PDAs, and tablet PCs (see figure below). Because the CIX is built on open standards, the Strata CIX will also work with standards-based Toshiba certified SIP telephones.
- Each individual user can choose the type of device that best meets their communication needs.

These devices can be used by local or remote users, so employees can work anywhere, with the same level of functionality and productivity.



## FeatureFlex Next Generation Adaptability

In addition to the new IP features, the Strata CIX delivers all the features and functionality of Strata CTX digital business telephone systems, taking advantage of Toshiba's decades of experience serving enterprises with voice solutions.

**So revolutionary it's a "Disruptive technology," changing the face of telecommunications**

The adaptability capabilities in the Strata CIX that we call FeatureFlex are so powerful, it will revolutionize the industry. It's the first telecommunications system to be truly customizable to the needs of each user, making changes on-the-fly, in a short time, instead of months or years, or waiting for the next release of software. You can actually serve the needs of what we call a "Market of one," meaning that one customer's custom features.

**Adaptability is much more than flexibility**

Every manufacturer of telecommunication systems claims their systems are "flexible," able to meet the varied needs of different customers by configurable settings within the system. Some even use the word "adaptable" to mean flexible, as if they were the same thing, and implying that configuration flexibility enables the system to be customized to each user's needs. This type of flexibility will often meet most of the customer's needs, but inevitably will fall short of the customer's expectations, and certainly does not constitute true customization.

### **Modify features and create new ones**

FeatureFlex adaptability and feature customization tools provide a level of next-generation flexibility you have probably only dreamed about.

- You can customize the functionality of the system beyond the programmable options provided by the standard system software or administration interface, so your specific needs can be met much better.
- You can modify existing features and create new ones.
- Not just the call processing, but blended features that work between all applications and resources of the entire system, including voice mail, CTI applications, etc.
- This is done through script editor capabilities, within the Strata Media Application Server, to interpret the code, re-order and process functions, follow custom routing, etc.

For example, you can use simple programming logic to create a call screening list of callers who get routed to try all your telephone numbers, internally, externally, or your cell phone. When the system finds you, it tries this number first when the next call comes in or you could create a call screening list of callers who you always want send to voicemail. You can even play special greetings to certain callers. All this and more is possible using FeatureFlex, the adaptability capabilities available with the Toshiba Strata CIX business communication system.

FeatureFlex allows users to customize their own individual features to help them be more efficient. FeatureFlex makes the resources of the system available to create new or blended features and applications company-wide, by department, or for individual users, right down to the market of one!

### **The next “Killer Application” will be different for every customer**

Today, we would probably be wrong if we tried to guess what the next “Killer Application” will be to most customers. That’s why Toshiba has focused on the “Killer Enabler” that allows enterprises to create their own Killer Application, which may be different for every individual user. With FeatureFlex running on the Strata Media Application Server, the Strata CIX provides the Killer Enabler, which allows us to address this “Market of One.” Users can now customize their systems in hours and days instead of waiting months or even years for their equipment manufacturer to add the features they want.

For example, using the system’s built-in Tool Command Language (Tcl) scripting language, enterprises can create applications that allow them to:

- Connect with back office systems to allow important information, such as inventory management, to scroll across the telephone LCD or PC screen.
- Connect with online sources for information, such as stock prices, weather temperatures, currency valuations, and more.
- Set up call management features that provide special handling for important calls, such as follow-me routing to forward calls to another number. It also can be set up to route calls from unknown callers (or any designated callers) directly into voice mail.

The CIX is architected to provide blended solutions, users can modify and create new features “on the fly”, which combine call handling with messages or other functions. The CIX is also compatible with TAPI, CSTA, and CTI databases via various scripting languages.

### **Do it yourself, or Toshiba can do it for you**

The best part is that Toshiba's FeatureFlex adaptability tools are practical and easy to put to work for you.

- Toshiba offers customization services if you don't have anyone on your staff that knows how to use the Tcl script editor tools (an interpretive language like PERL, Visual Basic, etc.), or if you don't want to hire a contract programmer to do it for you.
- Toshiba also offers FeatureFlex training classes when you're ready to get creative yourself.

### **Library of downloadable features already available**

Toshiba offers a library of downloadable FeatureFlex features. They are easy and cost-effective to implement and change to your specifications. Some highlights of Toshiba's downloadable features include the following; and we're just getting started:

- One Number Access – Callers can reach you at different locations inside or outside the office by dialing your single access number. You can set up routing features for incoming calls to go to all your devices or locations specified (cell, SoftIPT on laptops or PDA, home office, client location, voice mail). The System tries all your phone numbers in succession and when it finds you, it will use that number first when the next call comes in.
- Call Monitor and Retrieve – You can monitor a caller as he is leaving a voice mail message and answer the call if desired.
- Call Return – While listening to voicemail, you can call the person to whose message you are listening. When the call is complete, the system brings you back to the same place in the voicemail queue.
- Call Screening – From your personal "friends" and "enemies" list, calls either ring directly to your telephone or are sent directly to your voicemail.
- Alarm Clock – provides a simple alarm function on the IP or digital telephone. The alarm time can be specified by the phone and, when the time comes, alarm will be notified by the display on the phone and the announcement call to the phone. Third-party developer solutions.
- Hot Desk – Hot Desk enables users to share digital telephones in the office by assigning their directory number (DN) to one of the pre-assigned shared telephones through a login process. Once assigned, all calls to the user's DN terminate at the telephone, and the message waiting indicator shows the user's message status. The telephone will retain all of the user's feature button assignments. For more details, see "[Hot Desk](#)" on page 115.

FeatureFlex also opens the door to third-party application development, enabling software developers, telecommunications dealers, VARs, and systems integrators to create customized solutions for individual vertical markets and individual users.

# LVMU1A Voice Mail Card

## System Availability: CIX100, CIX200, CIX670, and CIX1200

The LVMU1A is an integrated voice mail card that installs in a slot (except a processor slot) of the Strata CIX100, CIX200, CIX670 or CIX1200 system. The LVMU1A has a 40 hour storage capacity and a maximum capacity of 8 ports.

## Features

The LVMU1A's features include:

- 2, 4, 6 or 8 port capacity with simplified licensing via eManager
- 40 hours of voice storage
- 360 mailboxes
- Call Monitor – Allows users to monitor callers leaving messages in their voice mailbox, with the option to retrieve the caller for a live conversation.
- Call Record – Gives users the ability to record live conversations from their Toshiba DP or IP telephones which are subsequently saved as voice messages.
- LCD Soft Key Control – User control of voice mailbox prompting with the aid of soft keys on their Toshiba LCD telephone screen.
- On board remote access modem
- Bilingual Support (English / Spanish)

The LVMU1A has direct backplane communication with the host system. It does not require any additional hardware, such as a BSIS. Caller information is presented directly from the CIX processor, so incoming calls are answered smoothly and efficiently, presenting a seamless voice mail experience.

The LVMU1A is easy to install. It comes pre-configured for installation into the Strata CIX100. This includes telephone system configurations as well as pre-programmed number of user mailboxes.

Also, since the LVMU1A is powered by the Strata CIX; in case of power outages, it can take advantage of battery backup protection from the CIX.

## Licenses

The Strata CIX software that supports the LVMU1A comes equipped with two port licenses for the LVMU.

Additional port licenses are available in two port increments for the CIX. These port licenses are licensed in the CIX and not the LVMU.

After installing the LVMU1A, dealers need only apply additional voice mail port licenses to increase the LVMU1A's capacity to the desired number of ports. All licensing is applied via our eManager administration terminal, while voice mail programming continues to be managed by the Stratagy UAdmin software.

## Software

The software requirements for the LVMU1A are:

- Strata CIX Software R4.2 or higher
- eManager Version 4.20A09 or higher
- UAdmin Version 2.1

## Port Upgrades

Each Strata CIX Release 4.2 or higher processor is equipped with two LVMU port licenses. Additional voice mail ports require FYI licensing. Upgrading the number of voice ports on the LVMU1A is as easy as upgrading the CIX processor (R4.2 MP026 or higher is required). Upgrade licenses (LIC-2 LVMU) are purchased via normal processes and then activated through FYI Licensing. The activation code is applied to the Strata CIX Processor via eManager. The license is stored on the CIX processor rather than the LVMU1A.

## GVPH1A Voice Mail Card

The GVPH1A is a plug and play voice mail circuit card specifically designed for the Strata CIX40 cabinet. It plugs into a dedicated cabinet slot and requires no additional hardware to provide its full set of features. The GVPH provides four voice mail ports without any licenses. With CIX40 R5.10 software, the GVPH voice mail port capacity can be increased from four to six or eight voice mail ports using the 2-port LIC-2 GVPH license.

For more details, refer to [“GVPH – Integrated Voice Mail” on page 7](#).

## Other Voice Processing Systems

For general information concerning the other voice processing systems offered by Toshiba, please see the Strategy General Description.

This page is intentionally left blank.

This chapter contains the Strata CIX features. They are presented in alphabetical order to make it easy to locate each feature. System availability below a feature title informs you of the Systems that support the particular feature.

## Account Codes

**System Availability:** All systems

Account Codes are often used for cost allocation of the call or the time the caller was involved on a phone call. The codes are printed on a Station Message Detail Recording (SMDR) printout along with other call details so that the customer can identify all calls associated with a specific account code.

Account codes may be forced (required after dialing all or specific phone numbers) or voluntary (optionally entered anytime during calls). Codes can be as long as 15 digits and can be verified or non-verified by the system. An account code feature button can be programmed on a digital telephone to make voluntary account code entry convenient and easy.

## Add-on Module (ADM)

**System Availability:** All systems

One to two LM5110's (10 button) can be attached to DP5000-series digital telephones (except DP5008) and IP5000-series telephones to provide an additional 20 programmable buttons.

One to two KM5020's (20 button) can be attached to the DP5000-series digital telephone (except DP5008) and IP5000-series telephones to provide an additional 40 flexible buttons.

One to two IADMs can be attached to an IPT2000-series telephone to provide an additional 20 or 40 flexible buttons.

ADM buttons can be programmed with outside line or Directory Number buttons, Direct Station Selection, One Touch Speed Dial or any other flexible feature button. For more information, see [“Telephones and Peripherals” on page 45](#).

## Advisory Messages

**System Availability:** All systems

Any telephone user can set a message on his or her telephone. Whenever another station with a display calls a station with a message set, the information in the message displays on the calling station's LCD. This feature allows users to define their current status and make that status available to others attempting to call that person. This status is also sent to Attendant Console positions.

## Alarm Notification

**System Availability:** CIX100, CIX200, CIX670, and CIX1200

The Strata CIX can send alarm notifications to a Monitoring PC/Server or send an alarm notification to a telephone. The Strata CIX Network eMonitor software application provides system alarm monitoring functionality, either remotely or locally over TCP/IP.

System alarms can be sent to up to 11 unique eMonitor PC consoles IP addresses from Strata CIX SNMP traps. Alarms can be sent from multiple networked Strata CIX nodes to one or more eMonitor consoles.

Alarms include trunk failures on ISDN PRI, T1, or IP interfaces. System resource alarms include cooling fan failure (CIX200 only), MIPU / LIPU or BIPU-M card data set problem, SMDR memory buffer full, SMDR link down (LAN/RS-232c), SMDI link down (LAN only), CTI link down (Attendant Console, ACD, external Stratagy system), and Expansion cabinet power supply failures.

## Alternate Answer Point

**System Availability:** All systems

Users can answer a transferred internal or outside line call from any station that has a Directory Number button appearance of the “transferred to” Directory Number.

## Automatic Busy Redial

**System Availability:** All systems

Automatic Busy Redial (ABR) enables a digital or standard telephone user to automatically redial a busy outside number multiple times at programmed intervals. Strata CIX supports a maximum of 16, 32 or 48 simultaneous registrations of ABR (limited by the number of busy tone detectors in the system). Each station may only have at most one call registered with ABR at any time.

## Automatic Call Distribution (ACD) Server

**System Availability:** All systems

An external ACD software option with the Strata CIX is provided by connection of an external PC-based CTI application server or as an application on the MAS. The CTI server runs both the ACD call processing application and the separate Management Information System (MIS) application such as Insight CIX, as well as other CTI applications.

The ACD application is available in Basic and Enhanced feature functionality, along with the number of groups and active agent size increments to provide cost-effective pricing levels according to the user’s needs. Enhanced ACD includes all basic capabilities plus multiple group login, skills-based routing, priority queuing, time scheduled ACD queues, agent and call priority escalation handling, and balanced call count agent search. For more information, refer to the *Strata CIX and CTX Call Center Solutions General Description*.



## Basic ACD Features

### Advanced Call Routing

The optional Call Router enables calls to be routed based upon parameters such as Caller ID, Account Numbers, private lists, time-of-day, day-of-week, day-of-year, and user entered data (account code, etc.). This is an optional feature that can be added to the ACD application.

### Intelligent Announcements

The holding caller can be informed of call status, such as their place in queue or estimated time before an agent answers. The intelligent announcement function can also offer alternative options to continuing to hold, such as going to voice mail.

### IVR Voice Assistant Open Database Connectivity (ODBC) Access

There are two options that can be used with customized services: Interactive Voice Response (IVR) Voice Assistant (VA) application can be used as a stand-alone product and/or as an IVR service to the ACD application. For example, an IVR port could be used to do an external page to alert agents to return and login to an ACD queue when it gets too overloaded with calls.

Other useful functions include gather and validate user input, play menus and act on response, and trigger other events. The IVR VA can also be used to provide low cost text to speech capabilities. The IVR VA is an optional feature that can be added to the ACD application.

## Enhanced ACD Features

### Agent Priority Routing

The Agent pool can be expanded when traffic gets heavy based upon agent priority levels. When all agents are busy at one level, calls automatically get distributed to agents at the next level. Calls can be distributed by agent priority, preferred agent treatment, or balanced call count.

### Multiple Group Agent Login

ACD agents can be logged into multiple ACD groups, enabling agents to answer calls for multiple groups. This is very useful for back up coverage between groups. It is also the foundation for skills-based routing and agent priority routing, enabling many advanced call center applications.

### Skills-based Routing

Based on the caller's input, the system can route the call to the agent best suited to handle the call. Calls can be routed to certain agents, based upon agent capabilities, in addition to Dialed Number Identification Service (DNIS), CO line, or Auto Attendant routing into different groups. With the capability for agents to log into multiple groups, calls can be routed to different agents based upon skills needed for each specific call.

### Priority Queuing

ACD calls can optionally be tagged with a priority number before they are placed into the ACD group queue. The priority number assigned to the call determines where the call is placed in queue. This feature enables high priority calls to be answered sooner than low-priority calls. The escalation parameter ensures that no call is lost by higher priority calls.

## Automatic Callback (ACB)

**System Availability:** All systems

When a station user dials a busy station [DN] or outside line access code and receives busy tone, ACB can be activated by pressing an ACB feature Soft Key or by dialing 4. When the busy [DN] or outside line becomes available, the station will be automatically called back and be connected to and ring the originally called station or receive dial tone from an outgoing line.

When ACB is activated, the calling station receives success tone followed by busy tone. Once ACB is activated, the caller can hang up. ACB can be canceled any time using an access code. It will also cancel automatically after a predetermined time.

## Automatic Line Selection

**System Availability:** All systems

This feature automatically connects a telephone to a specific line or extension button when the user lifts the handset off-hook, presses the Spkr (speaker) button, or presses a digit on the dial pad (Hot Dialing). This feature is necessary to make telephone operation consistent for the user because a telephone can have up to 20 line and extension buttons. Each telephone can be assigned in system programming with various options that determine what type of line or extension button is selected when the user takes the handset off-hook to make or answer calls.

When answering calls, this option can be set to answer the call or not when a call rings the telephone and the user takes the handset off-hook. If the option is set to not answer automatically, the user can press the ringing button on the telephone to answer manually. With Automatic line selection, if more than one type of call is ringing simultaneously on the telephone, this option selects which type of call will be answered as a priority, then the longest ringing call in that call type will be answered first.

Automatic line selection options are set independently for each telephone, for originating new calls and answering ringing calls. This feature can also be disabled on all or selected telephones to allow users to manually press a button to originate or answer calls.

# Automatic Release

**System Availability:** All systems

The system will automatically release line connections under certain conditions.

## Automatic Release from Hold

When a line is on hold and the held party hangs up, the line is automatically released. Individual loop start CO lines can be programmed to detect disconnect supervision signals from the CO and to respond by releasing the line. If the CO does not provide Disconnect Supervision, the user must manually retrieve the held line and then hang up.

## Automatic Release of Incoming Calls

An outside caller may be placed in a queue waiting for an external application to handle the call such as an Auto Attendant, IVR, ACD or other device. If the CO line for that call does not offer “disconnect supervision,” that call may remain in a holding position until forced to release the connection.

This feature provides full use of all CO lines at all times. A CO line is not tied up if the call goes unanswered and no alternative call handling is provided. This is very useful for disconnect supervision in voice mail and built-in auto attendant applications, but availability and reliability of the signaling from the CO must be confirmed.

## Station Automatic Release

When the distant party disconnects from a call, the remaining digital telephone is automatically made idle, busy tone is not sent to the speakerphone or handset, and the digital telephone is automatically released. A digital telephone is released and returned to idle state. A standard telephone is simply released and returned to standard dial tone. The programming choice for this feature is system wide.

# Background Music (BGM)

**System Availability:** All systems

Background music audio can be played through the speakers of digital telephones and external paging equipment. The Strata CIX supports up to 15 BGM audio input interfaces. Selection of which BGM source is played can be done individually by each telephone user and for each external page zone through the System Administrator’s telephone.

# Call Completion

**System Availability:** All systems

When calls are not completed because the station does not answer, is busy, or is in Do Not Disturb. A series of options are available to the user when encountering these conditions. They include changing the calling signal from Voice Announce to Ringing or vice versa, setting Automatic Callback, setting the Message Waiting light, Camp on Busy, Overriding the condition with Privacy/DND/Executive Overrides, or using Off-Hook Call Announce.

These options are easily activated by dialing a single digit code or pressing a soft key when the condition is recognized. These options are individually set for each telephone to be able to activate the call completion feature and separately to permit the feature to be activated when called.

# Call Forward

## System Availability: All systems

Call Forward diverts internal and external calls intended for a Directory Number [DN] to a destination specified for that [DN], under calling conditions specified for that [DN]. Call Forward may be activated from the station that owns the [DN] or remotely from another station or from outside the system from a DISA line. Call Forward may be applied to any [DN] ([PDN], [PhDN], or Pilot [DN]).

There are two types of Call Forward options: System Call Forward and Station Call Forward. Each type may be activated independently or simultaneously for each telephone. If Station CF is activated, it will override System Call Forward on some or all calls.

## Station Call Forward

Station users can set their individual call forwarding conditions and destinations as they choose (see “[Call Forward Conditions](#)” and “[Call Forward Destination](#)” in this section). Station forwarding has priority over System Call Forwarding, if set.

Station Call Forward provides two types of Call Forward (Any Call and Incoming line calls only). One type directs any type of a call to a designated destination; the other type directs only private or DID lines to a designated destination. Both types can be set on a telephone simultaneously with each type having a unique destination.

This allows the user to forward incoming calls on private or DID lines to a different destination than internal or transferred calls. If private and DID line calls are set to forward independently to an alternate destination, then internal and transferred calls will forward to another destination per Station Call Forward (any call) or System Call Forward.

## System Call Forward

A system option is available to forward unanswered calls to voice mail or some other pre-determined destination. This option is set up for each station by the System Administrator using eManager. This ensures efficient call handling and better service to callers even when station users do not have Station Call Forward set at their telephone. Call Forwarding can also be set up by department with a special mailbox or destination with the use of Phantom Directory Numbers [PhDNs].

There are 32 or 48 different System Call Forward patterns that can flexibly forward calls with unique call type, condition and destination settings. Each pattern can be set up and assigned to individual stations by a System Administrator using eManager. Any pattern can be applied independently to each station’s [PDN] or [PhDN]. System Call Forward patterns applied to stations can be changed automatically per Day/Night CO assignments.

Although System Call Forward is set up and assigned to individual telephones by a System Administrator, each telephone user can turn the feature On/Off from their telephone using a One Touch button or access code. Station Call Forwarding always overrides System Call Forward.

With Release 1.3 and higher, you can enable/disable System Call Forward Cascade, which means that a call that forwards to a destination that is also forwarded will follow the destination’s call forward.

## Call Forward Conditions

Call Forward (CF) conditions refer to the status of the [DN] that causes a call to forward. Whether using Station or System Call Forward, the CF conditions include: Busy, No Answer, Busy-No Answer, and All Calls (station CF only). Call Forward No Answer times are set individually for each station in Station Call Forward and system wide for all System Call Forward Patterns.

**Note** OCA and Voice First Calls will not Call Forward-No Answer unless the caller presses 1 to switch the call to tone ringing.

## Call Forward Destination

Whether using Station or System Call Forward, the CF destination can be an internal Directory Number, a Hunt or ACD Group, Voice Mail, or a public or private network telephone number.

In the last case, the forwarded call will access an outside line or line group and dial an external telephone number. Both the line access code and the telephone number are set in the Call Forward destination during the Call Forward setup operation.

Station Call Forward allows one destination per each type of Station Call Forward (Any Call or Incoming Line Calls) set on a telephone. System Call Forward allows two destinations per Call Forward pattern: the Primary Destination and an alternate, in case a call cannot forward to the Primary Destination (e.g., the Primary Destination has been unplugged or malfunctions).

## Call Forward – Call Types

In each System Call Forward pattern, the Call Forward conditions and destinations can be set independently.

For Station Call Forward, the destination and condition for each station can be different for incoming CO line calls, and internal and transferred calls.

## Call Forward Remote

A station's personal call forwarding destination can be cancelled or changed to another outside number or an internal voice mailbox either remotely via DISA or from another user's telephone. Changing Call Forward remotely is password protected. System Call Forward can be changed locally or remotely using eManager.

## Call Forward Override

See [“Call Forward Override” on page 134](#).

## Call History

### System Availability: All systems

Incoming calls with Caller ID or ANI information may be optionally recorded into a rolling list for the station where the call is ringing. The call is placed in the list along with the number, name (if provided), time and date of the call, and status of the call (answered, abandoned, or redirected). This list is accessible by the user from the telephone LCD and any call may be selected and redialed using the flexible Caller ID or Hist button.

When calls ring a button (Line or [DN]) that appears on multiple stations, the number is stored on the telephone that is designated as the owner of the Line or [DN] and on the telephone that answers the call. If an incoming call is directed to a telephone, but the call is not answered by that telephone because it hunts or forwards to another destination, the call record will still be stored on that telephone as “redirected” and on the telephone that answers the call as “answered.” If a call is not answered, it is stored on the line or [DN] owner’s telephone as “abandoned.”

To store call records, a telephone must be allocated Call History memory by the System Administrator. The number of call records allowed per station and the total number of call records per system is provided in [Table 54 on page 179](#).

## Call Monitoring and Transfer

### System Availability: All systems

This feature is available on the following Voice Mail systems: Strategy on MAS (with all CIX systems) and GVPH (with CIX40). This optional feature enables a mailbox user to monitor a message while it is recorded in his mailbox from his telephone and optionally transfer the message to a caller. This feature is active when the User’s telephone is idle or for calls that are forwarded to Voice Mail, and when a message recording begins.

To operate, this feature must be initially enabled by the mailbox user. The default is disabled. The Call Monitor feature works only with real extensions or PDNs.

When a call is forwarded to a voice mail system and recording starts, the mailbox owner’s telephone displays a message indicating that a voice message is being recorded with the appropriate Caller ID information. Also there could be a beep tone or audible alert at this point. If the mailbox owner has DND enabled, there should be no beep. If the mailbox owner is present at this moment, he can press the “Call Monitor Button” to hear the caller leaving a message. The message plays in real time. When the caller stops the recording, the monitoring terminates, and the mailbox user will hear the prompt “The caller has finished. Good bye.”

You cannot cancel or rerecord from the voice mail system when Call Monitoring and Retrieve feature is enabled and invoked.

The mailbox user has an option to interrupt message recording and speak to the caller. In this case, the mailbox owner presses the “Call Monitor Button” button on the telephone. The caller leaving a message will be interrupted with a prompt such as “Bill Jones is now available, please hold while your call is being transferred”. The system will connect the caller to the mailbox owner, which will hear an audible tone once the connection is complete. Other callers are not allowed to ring the mailbox owners phone once the “Call Monitor Button” button is pressed.

When more than one caller is leaving messages at the same time, then the mailbox user is able to monitor the last caller.

# Call Park

**System Availability:** All systems

Call Park gives any station, regardless of type, a method for holding calls. By parking a call, you are free to make other calls and retrieve the call at a later time or use the paging system to announce a call to be picked up by someone else on the system. Any call can be parked. Parking a call to your phone is known as Local Park, parking a call on someone else's phone is known as Remote Park, and if a general orbit is used, it called Auto Park.

## Call Park Orbits

The Call Park feature enables a station user to place a call temporarily in an orbit so that the call can be retrieved by any user, either from the same station or from a different station. Personal Park Orbits are available to any type of telephone, including standard telephones. If a call is parked, but not retrieved within a preprogrammed time period, it will recall the parking telephone. The Park recall time is set individually for each station.

Refer to [Table 54 on page 179](#) for the number of General Park and Personal Park Orbits, depending on the system processor.

## Park and Page

This feature enables station users to park a call (in a General or Personal Park Orbit), enter a Page Zone or Group access code, and then announce the orbit number of the waiting call to the Paged party. A pre-programmed One Touch button can be assigned to telephones to automatically connect to a predesignated External Paging circuit, a Telephone Paging group or both.

# Call Pickup

**System Availability:** All systems

Call Pickup enables station users to pick up all types of ringing or held calls including internal, [PDN] or [PhDN] calls ringing or on hold at other stations. Station users can also pick up CO/DID/Tie line calls ringing or on hold at other stations, CO lines ringing during Night Mode to External Page or night bell, tandem CO line connections and Door Phone calls. Call pickup can be performed through programmable buttons (Directed Pickup, Group Pickup), or with an access code.

# Call Waiting

**System Availability: All systems**

When a station is busy with a call and another call is directed to that station's busy Line or [DN] button, two short beeps are issued to alert the telephone user of the pending call.

Call Waiting works for calls originating from within or outside the system. The length of the Call Waiting beeps is different for internal and external Call Waiting. The different beeps distinguish which type of call is waiting.

Caller ID, DNIS or ANI information appears on LCD telephones for 10 seconds. If Caller ID information is not available, the device name, such as the CO line or DNIS name or number is shown.

Digital telephones can be adjusted to receive or not receive Call Waiting tone over the handset or headset receiver, as well as the speaker. Standard telephones will receive Call Waiting tone twice from the handset receiver. Call Waiting tones can also be turned off on each station by a System Administrator.

When a station is busy with a call and another call is being received, a tone alerts the caller of a pending call. On LCD telephones, the Caller ID information displays for 10 seconds. The combined effect of the Call Waiting alert tone with the displayed information enables users to identify whether or not they want to interrupt their current call for the waiting call.

To answer the Call Waiting, the current call must be parked, terminated or transferred. Multiple calls can be queued to a single station, all waiting for that station to become free; the call at the head of the queue provides the Call Waiting signal and LCD indication.

This feature works with both digital and analog single-line telephones. The tone (two beeps) signaling Call Waiting tone is provided through the speaker of the digital phone. For standard analog telephones, the tone is inserted into the speech path. Caller ID display is not available with standard telephones.

**Note** Type II call waiting with Caller ID is not available with the R4.1 release of the BSTCIU or BCOCIU/BCOCIS interface cards.



# Caller Identification

**System Availability:** All systems

Caller Identification (Caller ID) is the general term for the information provided identifying the originating party of a public network call. The name and telephone number of the calling party displays on the ringing telephone's LCD. Incoming calls with Caller ID or Automatic Number Identification (ANI) information may be optionally recorded into a rolling list for individual stations. Station users with LCD displays can access this list to select and redial these calls (see Call History). Caller ID service from the carrier must be subscribed on analog CO lines or T1 ANI in order to receive calling number and name into the Strata system.

Caller ID lists can include the number, name (if provided), time and date of the call, and status of the call (answered, abandoned, or redirected). Digital stations are assigned memory for creating the Call History. See [Table 54 on page 179](#) for the number of call records per system.

## ISDN Calling ID Name and Number

**System Availability:** Strata CIX100, CIX200, CIX670, and CIX1200

Both Caller ID name, if available from service provider, and number are supported for incoming calls using either ISDN NI-1 or NI-2 PRI lines. Caller ID names can be accepted by the Strata system from a CO with NI-1 or NI-2. NI-2 is the only way a 5ESS CO delivers Caller ID names on PRI. Nortel DMS CO with NI-2 installed also uses NI-2 to deliver Caller ID names. Only a Nortel DMS CO can provide Calling Names for NI-1.

# Camp on Busy

**System Availability:** All systems

## Automatic Camp On

When a call comes in to a busy station from an outside line and that station does not have an idle button for the call to ring in on, and Station Hunting or Call Forward is not applied, the call automatically camps on to the busy station. This permits incoming calls to be accepted even if the station is busy. The outside caller will receive ring-back-tone immediately and the called station will receive two bursts of Call Waiting tone.

If the calling line has Caller ID, ANI, or DNIS information, it will be displayed on the called station's LCD for 10 seconds. Auto Camp On also applies to incoming line calls directed to Hunt Groups, Voice Mail systems, etc.

Various types of internal calls from one station to a busy station, voice mail system or hunt group can also Camp On automatically with system programming options. For details on these types of calls see the Camp On-Busy and Station Hunting descriptions.

## Off-hook Camp On

A station caller who dials a busy station or line access code can remain off-hook to be automatically connected when the station or line becomes idle. After dialing a busy [DN] and receiving busy tone, the caller can just remain off-hook and Camp On will be initiated automatically after a predetermined time or the user can dial a 1 and remain off-hook to initiate Camp On immediately. When camp-on is activated, the caller will receive success tone followed by Ring Back Tone. The station that is the object of a camped-on call will receive two bursts of call waiting tone (see Call Waiting).

Even if Voice First is set at the called [DN], the station will be called by tone ringing when it is connected by Camp On. Internal and external stations can be the object of a Camp On. Calls may be camped on to the pilot number of Station Hunting groups and will be delivered to the first station in the group to become idle. ACD pilot numbers cannot be the object of a Camp On.

Incoming calls from outside lines to busy DN's camp-on automatically (see "[Automatic Camp On](#)," previous section). When a station dials the access code for an outside line and receives busy tone because all lines are busy, the user can remain off-hook and dial 1 to camp on to the busy line group. When a line becomes available, the station will connect to the line and receive dial tone.

When more than one party is camped on (queued) to a destination, the party with the highest Queuing Priority Level (QPL) will be connected first when the destination becomes available. If the parties have the same QPL, the longest waiting call will be connected first.

Calls will camp on to hunt groups when all members of the group are busy (see "[Station Hunting](#)" on page 138 for more details).

## Cancel Button

**System Availability:** All systems

The Cancel button voids the last entry or step in a procedure. This enables the station user to correct an error and then continue without having to start over.

It is important to consider the consequences of this button in regards to the overall task. For example, during a conference call, Cancel will disconnect the last party added to the conference.

## Centrex/PBX Compatible

**System Availability:** All systems

All system features are compatible with Centrex/PBX operation, including repeat of Centrex/PBX ringing cadence, one-button access to Centrex/PBX features, a two- to five-digit station numbering plan, and Delayed Ringing to selected stations.

## Centrex Ringing Repeat

**System Availability:** All systems

The system can mimic CO/Centrex/PBX ringing cadences received from outside lines when it rings a called station.

## Classes of Service (COS)

**System Availability:** All systems

Classes of Service are the mechanisms for assigning features and services to lines and stations within the system. The Class of Service for a given device, such as a station, is defined using 42 parameters. There are 32 Class of Service patterns available, each pattern can be set up to allow a unique combination of features. Each station and line group can be assigned independently to one of the 32 COS patterns.

## Computer Telephony Integration (CTI)

**System Availability:** All systems

CTI combines the capabilities of the Strata CIX digital business telephone system with custom functionality provided by computer applications. This can be provided through the LAN connection.

## Conference Calls

**System Availability:** All systems

Conference calling enables other people to join your conversation. These additional people can be inside or outside the Strata system. Any station can set up a conference with other stations or outside lines. A conference is defined as any time three or more parties join into one conversation. A maximum of eight parties are allowed into a conference with up to six from outside lines or standard stations. The originator of the first conference is the “master” and controls adding and deleting conference parties. The conference “master” can drop off the last added party by using the Cancel button.

### Conference On-Hold

A conference call may be put on Hold so that all the remaining conferees remain connected and no Music-on-hold is applied. The person putting the conference on hold may rejoin the conference by pressing the Line button on his phone. The Hold state of the conference can be released from another station by pressing the Line button of that station. At this time, the station that released the Hold state becomes Conference Master. This enables one person to establish a conference call for others.

### Join Button

Join allows an attendant or digital station user to connect two established calls to each other.

### Split/Join/Drop

This feature enables the conference master to add (Join) other phones to a conference. The conference master and another member of the conference can leave (Split) the conference for a private conversation. During this time, other conference members remain connected. The conference master can then Join both of the Split callers back into the conference, or the master can Drop (disconnect) the Split member he/she is connected to. This feature requires an LCD phone with Soft Keys. A flexible Split button can be added to a 3000- or 2000-series telephone to use this feature.

## Releasing from Conference Tandem CO Line Connections

This feature enables unattended line-to-line connections for the Strata system, freeing the conferencing analog station or voice mail port for other calls and important tasks. When a tandem connection is set up with a [DN] button, the [DN] button will go idle after releasing from the connection. The [DN] can then be used to make or receive calls from the originating digital telephone.

Standard telephones and/or VM devices can establish tandem analog CO line connections and then release from them without disconnecting the tandem connection in the Strata system. After releasing from a tandem call, reconnecting to the call can be accomplished by dialing an access code. This reconnect feature does not work if one or both of the CO lines are digital.

Whether or not tandem line buttons appear on a telephone, the telephone user can enter the connection and release the line that was connected to the original line or release both lines by pressing the Cancel button. For details on 2-B channel release from conference transfer, see [“Integrated Services Digital Network \(ISDN\)” on page 130](#).

## Voice Mail Conference

Voice Mail ports may be included in conference calls. This enables all members of the conference to listen to and play voice mail messages.

## Continuous DTMF Tone

**System Availability:** All systems

Dual-Tone Multi-Frequency (DTMF) dial signal is transmitted to the CO line or voice mail/Auto Attendant device for as long as the telephone user presses a button on the dial pad. This feature may be selected for each digital telephone. Standard telephones always provide continuous DTMF tone operation.

## Credit Card Calling

**System Availability:** All systems

Callers can make “0+” telephone credit card calls from selected toll restricted stations. When dialing from toll restricted stations, if the caller does not enter a credit card number after dialing “0,” the call will be disconnected. Calls are billed to the credit card instead of the Strata CIX CO line. The “0+” credit card calling feature can be enabled, selectively, or assigned to stations and CO lines capable of supporting this service.

## Data Privacy

**System Availability:** All systems

This option blocks calls to data devices that are in use. This prevents override calls and warning tones from interfering with data devices such as modems and ISDN data terminals.

# Day/Night Mode – Auto Schedule

## System Availability: All systems

The system has three operating modes that are based on the time-of-day, day-of-the-week, and up to 128 holiday schedules. The operating modes are Day, Day2, and Night. Each mode controls the routing of incoming line calls and settings for station and line Class Of Service restrictions. The system can be programmed to use all three modes, Day/Night mode only, or just the Day mode. The system switches automatically from one mode to the next based on the system's time-of-day clock.

Example Day/Night Mode Applications:

- **Incoming Calls** – Incoming line call routing of individual DID and DNIS numbers or ground/loop start lines change their ringing destinations automatically according to the date and time of day.

For example: On workdays, calls are routed to the attendant, individual telephones, ACD groups, etc., until 5:00 p.m. After 5:00 p.m., calls are routed off-premise to another office, to the Night Bell, or to night announcements and voice mail message boxes. On holidays and weekends, calls are routed independently to the appropriate holiday announcements or voice mail message boxes.

- **Class Of Service** – Station, lines, and DID numbers are assigned 38 options in Class of Service. These include Toll Restriction, Override privileges, allowed tandem connection, security code administration, etc. Any of these options can be changed independently for each telephone, line and DID number when the system switches from one operating mode to another.

For example: When the system changes from the Day to Night mode, selected stations can be automatically restricted from dialing outside or long distance calls. Note that outgoing route selections set in LCR are switched using a route selection schedule that is independent of the Day/Night mode schedule.

- **System Call Forward** – The System Call Forward settings for stations can be changed automatically when the system changes from the Day to Night mode. For example: During the day, a telephone can forward to a person's car or cell phone, and at night automatically forward to the person's voice mailbox.
- **Tenant Services** – Up to eight different tenants can each have different attendant or night bell assignments for day-of-the-week schedules using Day 1, Day 2, or Day 3 modes. This feature is enabled in system programming.

The system also enables users to manually change the Day/Night operating mode, even if the system is using the Auto Schedule feature. A Night Transfer button can be set on telephones for manually switching at any time from one mode to another. The button's LED flash rate indicates the system's operating mode.

If used with the System Auto Schedule operation, the Night Transfer button overrides the current Auto Schedule mode. However, when it is time for the system to switch to another mode per the Auto Schedule timer, the system will switch to the mode set by the Auto Schedule.

Example: If the system is switched from Day to Night at 2 p.m. manually with the Night Transfer button (Auto Schedule is set to switch from Day to Night at 6 p.m.), the system will still automatically switch back to the Day mode at 8 a.m. the next morning per the Auto Schedule.

## Delayed Ringing

**System Availability:** All systems

If an incoming external or internal [DN] call rings a station [DN] and is unanswered, alternate DPs can be programmed to ring at a later time. A separate delayed ring time can be set for each CO line group. The stations that were ringing initially will continue to ring after the Delayed Ringing begins. This feature is assigned for each line or [DN] button independently for each DP.

You can assign Delayed Ringing to voice mail and auto attendants. This feature can also be used to ring multiple (25 max.) telephones immediately or with a delay to voice mail, auto attendant and/or standard telephones by dialing a group pilot number. Each group member can have Immediate, Delayed Ring 1 or Delayed Ring 2. Delayed Ring times are adjustable (1~180 seconds) for each Multiple Call Group.

## Destination (Toll) Restriction

**System Availability:** All systems

Strata CIX offers Destination Restriction as a major expansion of traditional Toll Restriction. Historically, Toll Restriction was used to prevent the unauthorized use of toll prefixes to the PSTN: long distance (1), operator assistance (0) or international (011).

Strata CIX has expanded this to include restriction based on any string of dialed digits. A true, international business telephone system, Strata CIX can restrict any string of up to 11 dialed digits, including \* and #. Eleven-digit screening allows control of access to individual telephone numbers in remote Area Codes. Restriction of \* and # controls users' access to service codes from the CO, such as Camp On and Call Forwarding.

A stations' Destination Restriction level can be changed automatically with Day/Night mode Auto Scheduling. One use of this feature is to allow a telephone to make outside calls during the day, but to restrict them at night.

## Through Dialing

A telephone user or an attendant can connect a destination-restricted station to a trunk enabling temporary access to an outside line. The connected station can then use external dial tone to complete the call, and revert back to destination-restricted status after the call is completed. This maintains the integrity of toll restriction, while still extending outgoing calling privileges when necessary.

## Dial Directory

**System Availability:** All systems

Station users can dial by name using Toshiba's DP5000-series digital and IP5000-/IPT2000-series 10- and 20-button LCD telephones. The Dial by Name feature searches for names much like a cell phone directory and then allows the user to press on button to dial. This feature includes speed dialing and internal directory names. Your telephone will display names (First Name, Last Name or vice versa) depending on the way they have been programmed in the telephone system. All directory names are sorted alphabetically.

**Note** Dial Directory is not compatible with DKT2000-series digital telephones.

## Direct Inward Dialing (DID)

**System Availability:** Strata CIX100, CIX200, CIX670, and CIX1200

This feature allows external callers to dial directly to individual extensions or groups of telephones without intervention by an operator, IVR or auto attendant. Each incoming DID number, which is sent to the CIX on a DID line from the CO, can be routed individually to an extension, pooled or group line button, ACD group, maintenance modem, external page, night bell, voice mail box, or back out over the public or private telephone network. DID routing assignments can change automatically when the system switches between the Day and Night Modes.

DID numbers can vary between 1~7 digits in length for each DID line group. Each DID number can be assigned to 1 of 15 possible music-on-hold sources.

DID service is provided by DID analog, T1 or ISDN line interfaces.

## Dialed Number Identification Service (DNIS)

**System Availability:** Strata CIX100, CIX200, CIX670, and CIX1200

DNIS lines receive 800- and 900-type telephone calls that provide the number the caller dialed to reach the Strata CIX. The Strata CIX translates the DNIS number into a name that displays on the telephone's LCD. This allows the user to identify where the call is coming from and the purpose of the call before the call is answered.

The DNIS Name/Number routes calls to specific telephones, departments or ACD groups. When the call is ringing and after it is answered, the DNIS Name/Number displays on the telephone's LCD. The name and number display can also be sent to an agent computer to be used by a CTI application.

Applications include sending DNIS calls to a group of agents that take orders for a number of different companies and products. The agents know how to answer the calls from the DNIS display. Using DNIS capabilities allows one group of lines to be used to serve multiple applications. DNIS service is provided by DID analog, T1 or ISDN line interfaces and provides the same call routing options and destinations as DID calls.

## Digital Pad

### System Availability: All systems

The Strata system digital pad (decibel loss) is activated for the receiving path of the terminal, external line or resource.

The system adjusts for differing transmission levels between internal and external devices. This is very useful for conference calls when external parties have difficulty hearing due to public network loss. The Strata CIX can be programmed to insert the appropriate digital pad for each terminal and call type when establishing speech paths between telephones, external lines, and resources such as conference circuits, external paging devices, and external sound sources. This minimizes volume loss in conference calls.

The system recognizes these devices:

- Standard analog telephone (Type 500, Type 2500 and the equivalent)
- Toshiba digital telephone, cordless, wireless, door phone
- Analog trunk
- T1 trunk
- ISDN extension terminal (Audio and Speech)
- ISDN trunk/Tie line (Audio and Speech)
- Conference circuit
- Holding music source
- External paging device

## Direct Inward System Access (DISA)

### System Availability: All systems

Direct Inward System Access (DISA) allows outside callers to connect to the Strata CIX and make station or trunk calls as if they were stations within the system. An incoming call may be directed to DISA by Direct Inward Dialing lines, ground/loop start lines or Automated Attendant.

**Note** DISA lines require DTMF receivers.

DISA security code is changeable from a specific station. The station to change the security code needs to be allowed by Class of Service. This security code can also be changed using the Strata eManager administration software.

DISA provides access to the features listed below:

- Station Calls
- Station Calls over Private Network
- Attendant Access
- Account Codes
- Tie lines

DISA also provides access to these features, which require a security code:

- LCR
- Direct line access
- Outgoing line group access
- Emergency Call
- Call Forward Remote Control



# Directory Numbers

**System Availability:** All systems

A Directory Number [DN], sometimes called an “extension number,” is the number someone must call to reach a destination within the system. Each [DN] is assigned to a flexible button on a digital telephone or as the main directory number of a standard telephone. To maximize call coverage flexibility any [DN] can appear on multiple telephones. Also, individual telephones can have multiple [DN] buttons with different Directory Numbers.

The system provides Primary and Phantom [DN] buttons on telephones. All [DN] buttons can be used to originate and answer calls.

## Primary [DN] Buttons

Primary Directory Number buttons [PDNs] are needed to make calls and receive calls. It is a telephone’s main extension number. Each telephone is assigned only one [PDN] and that telephone is designated as the owner of the [PDN]. This [PDN] button can be made to appear multiple times on other telephones (see Secondary [DN] Buttons). Features, Class of Service, etc., are associated only with the station assigned as the owner of the [PDN]. [PDNs] that appear on telephones other than the owner telephone are referred to as Secondary DNs [SDNs].

## Phantom [DN] Buttons

Phantom [DN] buttons [PhDNs] are additional directory numbers appearing on telephones as extension buttons. [PhDNs] can be used as independent extensions on the phone or can appear on multiple phones to be used to allow call handling for departments or groups of telephones.

[PhDNs] can be used to make a telephone appear to have multiple [PDN] extension buttons. When assigning a [PhDN] for use as another appearance of the [PDN], the display properties are set the same as the [PDN] and a hunting sequence is set up to roll the calls from the [PDN] over to the other [PhDN]s associated with the [PDN]. With this arrangement, Call Forward will send calls to the [PDN]’s destinations and Voice Mailbox.

## Pilot [DN]

A Pilot [DN] is a pseudo-location that is assigned a [DN] where calls may be directed. Unlike [PDNs] and [PhDNs], a Pilot [DN] is *not* a button on any telephone. A Pilot [DN] is used as a device where calls can ring and be held while an external application using the Computer Telephony Interface (CTI) can control the call. To ensure calls do not get lost in the Strata CIX, a time-out and overflow service is provided to redirect the call when the link is down. Calls being held on the Pilot [DN] using the CTI link can specify any of the 15 on-hold music sources that are possible on the Strata CIX.

Pilot DNs are also assigned to Station Hunt Groups (for details, refer to Station Hunting).

# Distinctive LED Indicator

**System Availability:** All systems

Each feature button on a digital telephone has a Light Emitting Diode (LED) indicator. Distinctive LED indicators provide a method for quickly identifying the status of a line or feature button. The LED color or flash pattern can identify the call you are currently on, as well as other calls you are controlling, versus other calls that may appear on your telephone. Each telephone uses dual-color LEDs: green for lines you are using; red for lines used by someone else.

## Distinctive Ringing

**System Availability:** All systems

Users sometimes need to distinguish the ringing of one button on their phone from another button and sometimes stations in close proximity to one another need to distinguish the calls on one desk from another. Typically, multiple sounds are used to provide this distinction. Distinctive ringing can be assigned to each Line or [DN] button on each telephone.

You can set up to ten different incoming ringing tones for internal, as well as external calls. Previously, distinctive ring was not provided for internal calls.

## Do Not Disturb (DND)

**System Availability:** All systems

Station users with digital telephones can activate DND to prevent any calls from ringing their telephone. Callers will hear a fast busy tone when calling stations in the DND mode. Stations in DND mode can originate calls normally; however, they receive DND stutter dial tone (optional) when originating calls. With Release 1.3 and higher, users can disable DND stutter dial tone (1/2 sec. burst of busy tone before dial tone) in programming.

Call Forward-Busy will forward calls directed to a telephone with DND set, even if the telephone has idle [DNs]. Telephones with DND Override capability can ring DND telephones (see [“Do Not Disturb \(DND\) Override” on page 134](#)).

## Direct Station Selection (DSS) Buttons

**System Availability:** All systems

[DSS] buttons can be placed on digital and IP telephones, add-on modules and DSS consoles. When placed on one of these devices, these buttons serve two functions: to make direct calls or transfer calls to other stations; and to display the status of other stations and [PDNs].

The [DSS] button is numbered with a station's [PDN] and when pressed, calls that [PDN]. [DSS] buttons are not [DN] buttons, so they do not provide dial tone when pressed. The [DSS] button LED shows the status of the station and [PDN] it represents (idle, busy, DND or ringing). The [DSS] LED will turn on steady or flash at a unique rate, depending on the status (see “[DSS] Button Status Display.”)

The [DSS] LED displays the telephone's status for any type of call on any button, including [PhDN] and Line buttons. The [DSS] LED also indicates the status of the station's [PDN] itself. If the [PDN] appears as a Secondary DN [SDN] on multiple telephones, the DSS status will display Busy if any telephone is using the [SDN].

### [DSS] Button Status Display

**Red, steady:** Busy on a call not connected to your telephone

**Green, steady:** Busy on a call connected to your telephone

**Red, quick flash rate:** Ringing

**Red, slow flash rate:** Do Not Disturb

# DTMF Receivers

**System Availability:** All systems

DTMF receivers are used when receiving incoming DNIS DID, Tie or DISA line calls and when originating calls with standard tone-dial telephones. Voice mail systems also require DTMF receivers for a number of VM features, even if using SMDI or Toshiba Proprietary VM integration. Four circuits are automatically active with the initial basic processor. Activation of more than four receivers requires the purchase of a DTMF software license, in four-circuit increments.

DTMF receivers are built into the Strata CIX100, CIX200, CIX670, and CIX1200 processors. For the number of receiver circuits, refer to [Table 54 on page 179](#).

## DTMF Back Tone

The system can be programmed to allow or prevent Dual-tone Multi-frequency (DTMF) tones from being returned to digital telephones when a user dials on outside lines or sends DTMF digits to a voice mail device.

## DTMF and Dial Pulse CO Line Compatibility

When making outside calls, signals generated by pressing the dial pad buttons of a digital telephone are neither DTMF nor rotary dial signals – they are digital signals. The system can be programmed to translate these signals to either DTMF or rotary dial signals as required by the serving CO. Once the connection has been made, any further digits sent will always be sent as DTMF or rotary to allow the operation of devices at the other end of the connection.

## DTMF Signal Time

DTMF tones that are sent via Speed Dial to lines and via automatic dialing to voice mail devices can be set to 80 or 160 milliseconds, or continuously. The time can be set system wide independently for line out-dialing and for voice mail automatic dialing.

# Emergency Call

**System Availability:** All systems

An Emergency Call access code can be established in the Strata CIX to route calls to specified emergency destinations and to prioritize their delivery to those destinations. Up to four emergency destinations can be programmed for each mode of operation: Day, Day2 and Night. This is particularly useful in applications where employees, patients or guests are not expected to know where to call for help at different times of the day.

# Feature Prompting with Soft Keys

**System Availability:** All systems

As an alternative to dialing access codes and using feature buttons, station users with LCD digital telephones use Soft Keys (shown on their LCD) to access features. Abbreviated feature names appear during a call (when the telephone is in the ring or talk state) on the LCD above fixed keys. Users can select a feature by pressing the associated key. The LCD feature selections change according to the call state to provide the most logical options.

## Enhanced E911

### System Availability: All systems

Enhanced 911 calling means the routing of a call to the appropriate Public Safety Answering Position (PSAP) accompanied by Caller Emergency Services Identifier (CESID). The CESID identifies the location to which emergency services are to be sent. The Strata CIX can use two types of trunks to deliver E911 calls: ISDN Primary Rate Interface and CAMA (Centralized Automatic Message Accounting) trunks. Each 911 call generates an SMDR record at the beginning of the call to enable the business to initiate its own emergency response. Internal emergency destinations can also be automatically included in an emergency call. E911 calls can be routed across a Strata Net network for connection to the public network.

## External Amplified Speaker

### System Availability: All systems

The External Amplified Speaker (BESCB) is a six-inch, three-watt speaker with a three-watt amplifier built into a wooden speaker box. The amplified ringer can be used to:

- Amplify the ringing on a digital telephone.
- Provide a paging amplifier/speaker.
- Create an amplified talk-back speaker arrangement in an area where a telephone is not needed. The BESCB is installed as a speaker and connected to a door phone unit that is used as the talk-back microphone.

Amplified ringing can improve call handling in noisy areas where non-amplified ringing on a phone may not be heard.

A paging speaker ensures that paging announcements can be clearly heard throughout an area. In an area where a DP is not needed, a talk-back speaker provides a cost-effective communications solution.

The number of BESCBs that can be installed per system depends on the function of the BESCB. Any number of BESCBs can provide loud ringers for digital telephones. Only one BESCB can be installed if it is used as a paging or an amplified talk-back speaker.

**Note** A BHEU interface and an HESC-65A cable are required for each digital phone that has a loud ringing bell. IP telephones require HESC-65A, but not BHEU to support External Amplified Speaker. A 3000- or 2000-series digital telephone that has been upgraded with a data interface unit can be upgraded with the BHEU options, but older telephone models cannot.

## Flash Button

### System Availability: All systems

This is an optional button that can be assigned on digital telephones. It can be used either to disconnect a line and regain CO dial tone, or to gain access to Centrex features. The timing choice is set system wide through system programming. Standard telephones can dial an access code to flash Centrex lines.

## Flexible Line Ringing

**System Availability:** All systems

CO line ringing can be assigned to ring a specified [DN] on a station, a [DN] appearing on multiple stations, a Pilot [DN], a direct appearance of the CO line, a Pooled appearance of CO lines, or Group CO line appearance. These assignments direct the ringing of the incoming call based upon the three Day/Night Modes of operation and offer immediate and two delayed ringing parameters. The delay parameters are assigned for each incoming Line Group.

## Flexible Numbering

**System Availability:** All systems

The Strata CIX allows the system-numbering plan to be customized for the user's needs. Directory numbers, line and feature access codes, and Network Coordinated Numbering can be established uniquely in each system.

## Handsfree Answerback

**System Availability:** All systems

When a voice-announced internal [DN] call comes in to a digital telephone, users can answer without lifting the handset. Cordless and single line digital telephones and standard telephones are not compatible with this feature.

## Headset

**System Availability:** All systems

3000-series digital telephones may be optionally equipped with a modular headset jack by installing a BHEU circuit card.

IP telephones and DP5000-series digital telephones have a built-in headset adapter and therefore require only the headset.

## Hearing Aid Compatible

**System Availability:** All systems

All Toshiba digital telephones are hearing aid compatible.

## High Call Volume Buttons

**System Availability:** All systems

Release, Release/Answer, and Cancel buttons can be assigned to digital telephones. They enable a busy user to handle calls quickly and efficiently in high call volume situations.

With one touch of the Release button, a user can disconnect from a call. This is especially useful in headset applications. The Release/Answer button disconnects or transfers the current call, and answers the next. The Cancel button voids the last operation, such as disconnecting internal or external parties from conference or tandem calls.

# Hold

**System Availability:** All systems

There are several variations of Hold:

## Automatic Hold

This option enables a user to place a CO Line or [DN] call on Hold by pressing another CO Line or [DN] button. The user can then alternate between the new and the old call by pressing the desired Line or [DN]. If this feature is not activated, users must press HOLD before accessing another line and switching between calls.

## Analog Hold

This option enables a user to place a CO Line or [DN] call on Hold and the Line LED will flash on other DP telephones when the call is parked. This enables the call to be picked up from other telephones. This feature must be set in programming.

## Call Hold

This is the most commonly used. Call Hold temporarily suspends a call, allowing the station user to do other things, including using the phone. Callers on hold can receive music or announcements as described in the Music-on-hold feature.

## Consultation Hold

This is used when invoking other call features, such as Call Transfer or Conference.

## Exclusive Hold

A call can be placed on Exclusive Hold to ensure the privacy of the connection and that the call can only be retrieved by you, even if the held call appears on buttons on other telephones.

## Hold Recall

After placing a call on hold, it will recall the holding telephone after a predetermined time to remind the user of the held call. The hold recall time is set independently for each telephone (from 0~255 secs.). Hold recall time can also be disabled.

# Hot Dialing

**System Availability:** All systems

Hot dialing enables the digital telephone user to begin on-hook dialing without pressing a Line or [DN] button. The station can be programmed to automatically select a Line or [PDN] button when the dial pad is pressed while the station is idle. This saves a keystroke by not requiring the station user to press a [DN] or Line button to begin on-hook dialing. On-hook dialing saves time by not requiring the station user to lift the handset to begin dialing.

# Hot Desk

**System Availability:** All systems

**Important!** *Hot Desk is a FeatureFlex application and is available on a CIX system connected to the MAS. Hot Desk can be used on Digital telephones only.*

Hot Desk enables a telephone user to walk up to any telephone on the CIX system and register their extension to that telephone, along with all of its associated features/buttons.

When use of the shared telephone is no longer required, it is recommended that the user log out. The telephone is then released for another user, and calls to the logged-out DN will be routed to voice mail.

Although not recommended, the user may leave the telephone logged in. In this case, calls will continue to ring at the telephone and forward to voice mail if programmed to do so. If the user then logs in to another telephone, the old telephone's assignment is released, and the user can use his/her DN from the new telephone.

Following picture shows the concept of the digital telephone Hot Desk application.

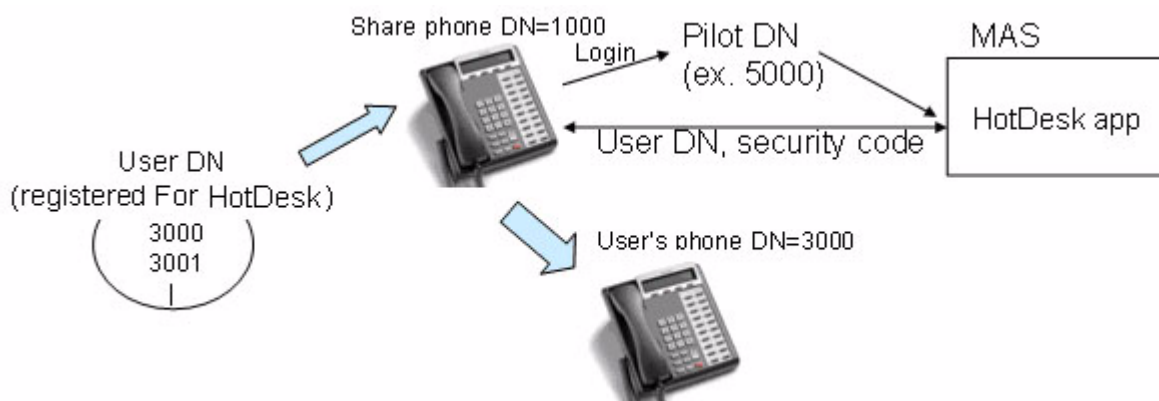

## Hot Desk Requirements

Shared telephones must be digital telephones. IP telephones are not supported by this FeatureFlex application.

A basic port license and a digital station card are required for each physical telephone which will be used for the Hot Desk application. An additional basic port license is required for each user who will be logging into a desk phone and using the Hot Desk Feature. These “virtual” extensions will be programmed into the CIX processor via eManager and will count against total system capacity.

For example, a Real Estate office may have a general area (sometimes called a bullpen) where home-based agents can use company facilities and telephones. If the number of digital telephones in the bullpen area is 8 and the number of home based agents is 68, the total number of digital station cards required for this application is one. This card is physically installed into the cabinet for connection to 8 desktop digital phones. The total number of basic licenses required for this application is 76 (8 hard phones and 68 virtual DN's).

Although the total number of actual telephones is small, this Hot Desk application would require a CIX670 because the CIX100 has a maximum of 72 DN's.

Shared digital telephones should have a sufficient number of programmable buttons to handle the needs of all users. Otherwise, users may lose some programmed button functions when logging on to a telephone with fewer buttons than their profile contains.

When a Hot Desk user is not using a shared phone, all calls to the user are routed to voice mail.

Add on modules and/or DSS consoles should not be used for telephones used by Hot Desk users.

## Hotline Service

### **System Availability: All systems**

If a station remains off hook for a programmable period, it can automatically be directed (immediately or with a delay) to a pre-programmed destination. The station may have partially dialed a number or have dialed no digits at all.

Each station is programmed with its specific ring down destination. This is particularly useful in applications where employees, patients or guests are not expected to know where to call for help at different times of the day. This feature is compatible with standard and digital telephones.



# IP Telephony

## Data Network Assessment for Voice Traffic

**System Availability:** All systems

**Important!** *Voice over Internet Protocol (VoIP) can be affected by numerous factors related to network structure and design. To prevent delays, jitter and voice data packet loss, and achieve optimum VoIP traffic performance, your network must be designed or redesigned for voice traffic with priority over data.*

Toshiba highly recommends that the installing dealer assess the existing network for proper handling of voice traffic and make sure it provides the required bandwidth per the number of deployed VoIP instruments. Toshiba is not responsible for: network assessment for voice traffic, network design/redesign or network support outside the topology it provides. Nor is Toshiba responsible for diminished Quality of Service (QoS) caused by networks not capable of providing necessary VoIP bandwidth.

Expected voice QoS as it relates to network parameters is shown in [Table 44 on page 171](#).

The CIX supports Toshiba proprietary IP telephones, enhancing the CIX VoIP capabilities, and providing powerful IP telephony add-on solutions for remote users. The Toshiba IPT2000- and IP5000-series telephones are compatible with all Strata CIX systems.

The Toshiba IP telephony strategy is based upon a transitional approach. For most enterprises, the migration path to IP telephony will be a gradual process rather than an event in time. Instead of acquiring IP technology benefits through complete system replacement at higher cost and higher risk, most enterprises prefer to integrate voice and data IP traffic into their existing telephone systems as the need arises. This protects their investment in existing voice and data networks and represents a low risk migration path. Toshiba has transformed Strata CIX systems into IP-enabled communication systems to achieve this very important objective.

## IP Interface Unit

**System Availability:** All systems

The MIPU / LIPU and GIPU / GIPH IP interface card works in conjunction with the system processor to provide distributed IP processing capabilities that include peer-to-peer IP telephone communication and IP Strata Net multi-system networking. MIPU / LIPU and GIPU / GIPH cards install in card slots in Strata CIX base or expansion cabinets.

The MIPU comes in two flavors: MIPU16 and MIPU24. The MIPU supports up to 24 channels even when the echo tail length canceller is set up to 64ms. The GIPU / GIPH installs into the Strata CIX40 system. The GIPU / GIPH card on the CIX40 supports up to 8 IP channels. The LIPU card can support up to 16 IP channels on all CIX systems. With the LIPS sub-card on board it can support up to 32 channels. Each IP card type has a Network Interface Card (NIC).

When programmed for G.711 codec, or G.729A with 16 ms echo cancel delay the MIPU, LIPU or LIPS supports 16 IP channels and GIPU / GIPH supports 8 IP channels. When programmed for G.729A codec and 32 ms echo cancel delay the LIPU or LIPS provides 12 of the 16 channels; on GIPU / GIPH 6 of 8 channels are available. Refer to the *Strata CIX Programming manual* for more details.

The MIPU / LIPU / LIPS / GIPU and GIPH supports all “IP” functionality in the Strata CIX. This includes the following:

- Multiple protocols supported:
  - MEGACO+ delivers a consistent user interface over all Toshiba IP endpoint devices, except SIP telephones. Toshiba has enabled the MEGACO protocol for call control to provide more stimulus/response capabilities that allows all the feature functionality of digital desktop telephones to be supported on IP telephones. The MEGACO+ protocol is able to implement this feature functionality consistency much better than could be done using other VoIP protocols.
  - SIP (Session Initiation Protocol) telephones provides basic functionality that can be used for very basic user capabilities. Toshiba supports only the Uniden telephone that Toshiba has approved for interoperability.
  - SIP Trunking is an application layer protocol used for establishing sessions in an IP network. SIP Trunking allows the CIX to get PRI like services from an Internet Telephony Service Provider using SIP.
- MIPU / LIPU/LIPS and GIPU / GIPH IP endpoint devices and interfaces (requires IP Endpoint license):
  - Toshiba IP telephones
  - SoftIPT on PDA, Notebook and TabletPC’s
  - Wireless IP Telephone
  - SIP IP telephones
  - Strata Media Application Server (MAS)
- MIPU / LIPU/LIPS Port devices and interfaces (requires Basic Port license on all CIX systems, except with GIPU / GIPH because all Basic Ports are fully licensed on CIX40).
  - IP Attendant Console
  - MAS Voice Mail Ports
  - MAS ACD Announcement Ports
  - StrataNet IP Network resources
- In addition to the above features, the MIPU also includes the following:
  - Backward compatibility with LIPU
  - Compatible in the CIX40, CIX100, 200, 670, and 1200  
The MIPU16 is compatible with the CIX40 with CIX Release 5.1 software.
  - Log files collected remotely from the MIPU
  - MIPU card uses one IP address
  - Tail-length echo cancellation increased from 32 ms to 64 ms (G.711 and G.729A)
  - Quality of Service (QoS) threshold alarm notification and measurement
  - IP Mobility support
  - Connects between a node using G.711 A-Law codecs and a node using G.711 Mu-Law codecs.
  - The maximum transmission interval of voice packet at using G.711 codec is 40ms (80ms in LIPU)
  - RTP ports used by IPTs can be user modified
  - Continuous rebooting (even after six failed attempts)
  - For a comparison of the MIPU and the LIPU refer to [Table 21](#).

## Miscellaneous

- The MIPU / LIPU / GIPU / GIPH supports both G.711 and G.729A standard codec compressions simultaneously. The type of compression used is set independently for each telephone in system programming.
- With the MIPU / LIPU/ GIPU / GIPH, the IP telephone works with DSL and cable routers.

The MIPU / LIPU / GIPU / GIPH operates on the network at 100 Mbps and can be connected to a fast switch router, LAN, WAN, etc. When connecting remote IP telephones to the MIPU / LIPU / LIPS and GIPU / GIPH over the Internet, a VPN router is needed to circumvent Network Address Translation (NAT) and firewall issues by tunneling.

- MIPU / LIPU / GIPU / GIPH provides MEGACO+ mobility to enable roaming. The LIPU / LIPS and GIPU / GIPH enables remote IP telephones to be connected over VPN and non-VPN IP networks.
- MIPU / LIPU / GIPU / GIPH firmware can be updated locally or remotely using eManager. This enables service personnel to update IP equipment with new features and enhancements as they become available. Updates require a brief interruption of IP telephone operation (a few minutes).

**Table 21 Comparison of MIPU and LIPU / GIPU / GIPH**

Feature	LIPU / GIPH	MIPU / GIPU
Channels	GIPH: 8 channels LIPU:16 channels LIPU+LIPS:32 channels	MIPU16:16 channels MIPU24:24 channels GIPU8:8 channels
Channel Limitation When LIPU / GIPH is set Echo canceller tail length to 32ms in G.729A.	GIPH: 6 channels LIPU:12 channels LIPU+LIPS:24 channels	No Limitation
Voice Codec	G.711 (Mu-law/A-law), G.729A	Same
Echo Canceller	G.168 (04/2000) Tail Length is Max 32ms.	G.168 (08/2004) Tail Length is Max 64 ms
IP Address to use	GIPH and LIPU: 1 LIPU+LIPS: 2	1
RTP Packet Transmission Interval	20/ 30/ 40/ 80 ms	G.711: 20/ 30/ 40 ms G.729A: 20/ 30/ 40/ 80 ms
VoIP Protocol Support	Megaco+, SIP (Terminal), Strata Net IP	Megaco+, SIP (Terminal), Strata Net IP, and SIP Trunking
Priority Control	Diffserve, IEEE802.1q (* <sup>1</sup> )	Same as LIPU
NAT Traversal	xIPU does not support IPT traversal	Same as LIPU
VLAN	LIPU and LIPS cards can be set separately	All channels are set the same.
QoS Measurement	LIPU/LIPS/GIPU to IPT, Between IPT and IPT	Between MIPU/GIPU and IPT Between IPT and IPT Between MIPU/GIPU
SIP Trunking	Not supported.	Supported <sup>1</sup>

1. Contact the Toshiba Sales Applications Desk for a list of approved providers.

## Network Address Translation (NAT)

The Strata CIX supports the use of IP telephones that are behind NAT firewalls. NAT allows multiple devices, such as personal computers and IP telephones to share a single public IP address. This is very common in home and small office broadband networks. A Strata CIX in the main office is able to support IP telephones at remote offices that are behind broadband routers and not connected by VPN – something not supported by some VoIP vendors. Of course using a VPN is more secure, but there may be instances where it is not practical. If you would like to support a mix of devices on the private network, and devices on the public network, see the guidelines below.

### NAT Firewall Guidelines

The use of a firewall between the Strata CIX, LAN or Media Application Server and the Public Internet is highly recommended. However, the use of some firewalls or routers with NAT requires proper configuration to avoid problems with IPTs registered to an MIPU / LIPU card.

### NAT General Guidelines

The following are general guide lines for successful IPT configuration.

- All MIPU / LIPU / GIPU and GIPH cards must have a Public IP Address if there are any public network IPTs. This allows the MIPU / LIPU and GIPU / GIPH to resolve the NAT translated IP addresses of both IPTs involved in the call.  
This also allows you to configure an IP phone or soft IPT to work on the LAN and have the same configuration work when you take the phone or laptop to another network.
- There must not be more than one NAT router between an IPT and the internet.
- The MIPU / LIPU and GIPU / GIPH must have a Gateway Address assigned.
- The MIPU / LIPU and GIPU / GIPH should be connected to the public network, through a firewall. The firewall should use a one-to-one NAT to give the MIPU / LIPU and GIPU / GIPH the same IP address on the public side and the safe side of the firewall.
- The MIPU / LIPU and GIPU / GIPH can not be located 'behind' a NAT (given a private IP address). However, it can, and should be behind a firewall.

### NAT Router Guidelines

There are three types of NAT routers available at this time.

- Full Cone — These are compatible with Strata CIX and Strata Net IP configurations.
- Partial/Restricted Cone — These are compatible with Strata CIX and Strata Net IP configurations.
- Symmetric — At this time these routers may cause unreliable service or cause unwanted symptoms. These routers are not compatible with Strata CIX and Strata Net IP configurations.

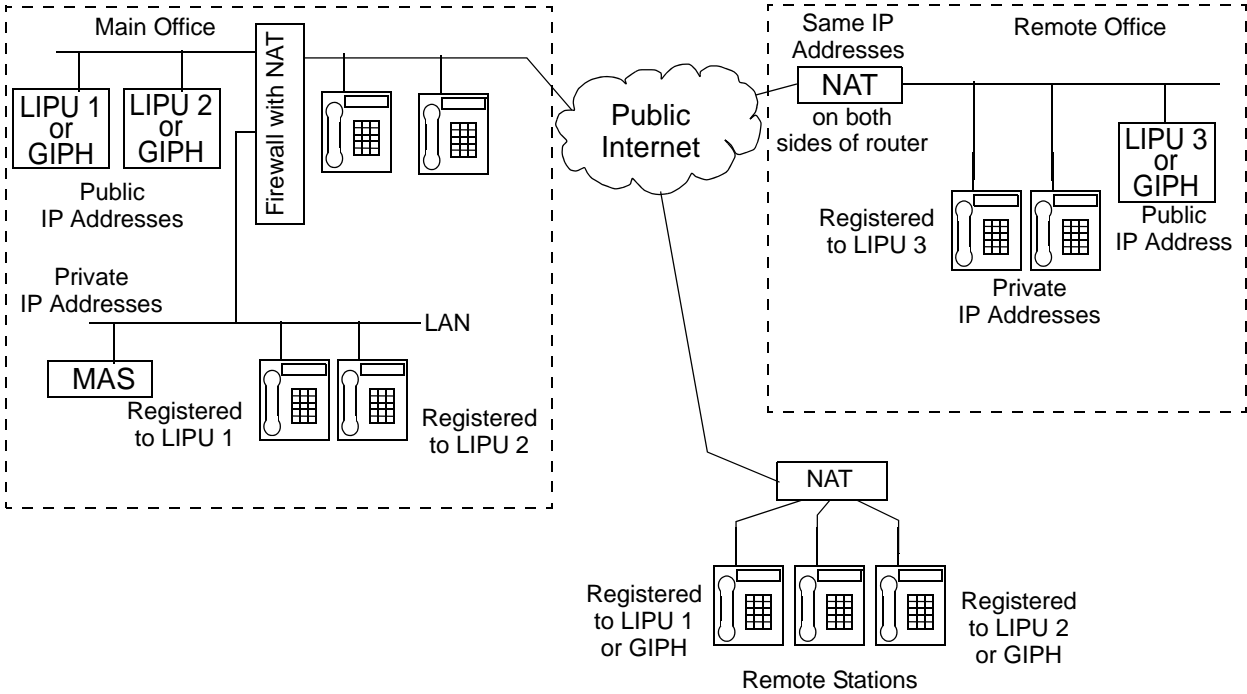

Figure 23 IP Telephony Configurations Using NAT Routers

## IP User Mobility

IP User Mobility is a set of features designed to give the user more flexibility in where they use their IP phone. IP User Mobility consists of three major features that allows the user to be mobile.

- Enables the user to log-off and log into any SoftIPT or IPT phone without having to make any configuration changes. This is similar to “Hot Desking” where the user can go to any existing IP phone and use his or her corporate directory number (DN) to log in. All button programming assigned to that DN will be applied to the extension.
- Enables the user to transfer registration of an extension that is currently in use. In essence, the user can log into another IP phone with his or her extension even if his extension is already in use by transferring the registration from one IP phone to another.
- Allows the Administrator to “oversubscribe” when building IP extensions. The Administrator can create and build more IP stations using eManager than there are physical ports.

### Advantages

- Multiple users can share one IPT (hot desk) or one SoftIPT.
- Logout function allows a user to log-off his/her extension to free up resources or log in at that IPT.
- Better security when logging in is provided by using the Password field. The password is programmed on a per-DN basis.
- IP User Mobility incorporates a primary and secondary IPU IP address. When an IP phone boots up, it first tries the primary IPU address. If the attempt is unsuccessful, the IP phone automatically tries the secondary IPU address.
- IP User Mobility works across multiple nodes. Any IP user can log into any IP phone in any node without manually entering a dedicated IPU address.

### Requirements

- CIX Software: R5.00 MR14 or higher
- SoftIPT: 02.00.0000
- MIPU: MIPU01\_01 or higher
- GIPU: MIPU01\_12 or higher
- GIPH: GIPH\_02\_03 or higher
- LIPU: LIPU\_02\_03 or higher
- eManager: V5.00 A07 or higher
- IPT20X0-SD: DIP2T2G
- IPT2008: DIP2M2G
- IPT2010: DIP2T2GX-A06
- IP5000-series: All versions

**Note** IP User Mobility will run on an MIPU and an LIPU version LIPU\_02\_03 or higher. IP Mobility is not supported on the BIPU.

## IPT Anywhere

### System Availability: All systems

IPT Anywhere enables you to connect IP telephones remotely through the Internet and use all Strata CIX telephone features. IPT remote connections can be set with or without the use of Virtual Private Network (VPN). VPN connections provide increased security and are recommended for permanent type IPT remote connections. When moving IPT telephones frequently to different locations (hotels, conferences, etc.), non-VPN connections are more practical.

When using home type xDSL or cable connections, only one or two IPTs may be connected because of xDSL and cable bandwidth limitations. High speed T1, fiber, or Asynchronous Transfer Mode (ATM)-type connections are required when installing more than two IPTs at a remote site.

An Internet configuration could use the following connections:

- No VPN, and thus, no security
- Third party VPN software residing on DHCP gateway server. To connect IPTs over the Internet, using third party or Microsoft VPN software residing on a DHCP gateway server, see [Figure 24](#).
- ATM (IP over ATM virtualization by VC/VP)
- Broadband Ethernet virtualization by Virtual LAN (VLAN)
- IP-VPN (IP-VPN based on Multi-protocol Label Switching (MPLS))
- Private line connection

For an access line to link the user's location with the access point of the carrier or provider, using a private line, broadband line (xDSL, CATV), or fiber optics is recommended.

The IPT Anywhere feature enables remote IP telephone users working in branch offices or home offices to make full use of the extension features of the Strata CIX. The diagram below shows IPT Anywhere connections using the optional VPN connection.

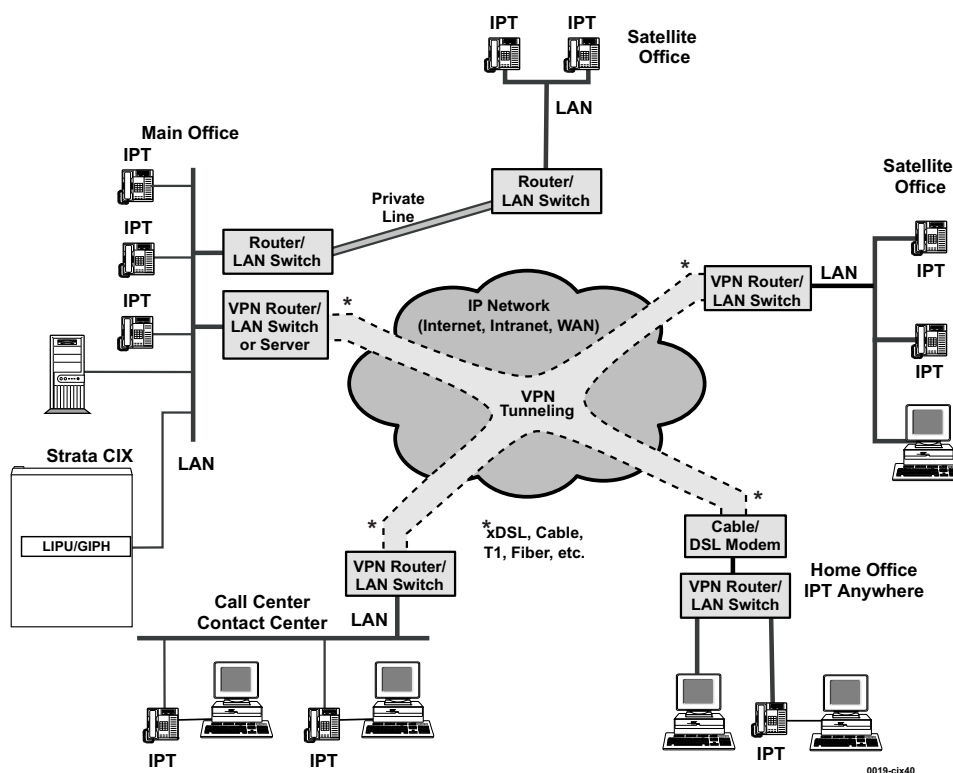

Figure 24 IPT Anywhere Example

## Quality of Service (QoS) and Bandwidth

### System Availability: All systems

In any telephone system, deploying many IP telephones on a data LAN can have some unexpected pitfalls if the network does not have the bandwidth and speed required to handle VoIP traffic. To prevent delay, jitter, and data loss for VoIP traffic and retain the performance of your other business-critical network applications a Network Voice Readiness Assessment must be completed before installing VoIP. Toshiba is not responsible for Network Voice Readiness Assessments.

More information about Voice Readiness Assessment can be found at <http://www.netiq.com/products/vm/whitepapers.asp>.

CIX IP provides a number of adjustable tuning parameters dealing with sharing of network resources, collectively referred to as Quality of Service (QoS). Expected voice QoS as it relates to network parameters, including bandwidth, is shown in [Table 44 on page 171](#).

Some CIX IP voice quality adjustable parameters are listed below:

### System Wide Parameters

- Software selectable G.711 or G.729A codecs with variable interval timing
- Type of Service (TOS) precedence, delay, throughput and reliability types can be individually selected
- Differentiated Services (Diffserv) can be enabled

### IP Telephone Group Parameters

- IP Telephone Groups (CIX1200: 256 groups; CIX670: 256 groups; CIX200, CIX100 and CIX40: 128 groups)
- Voice Packet Transmission Interval
- Jitter buffer type
- Jitter buffer length
- Packet loss threshold

### Priority Control

Priority Control can be enabled system wide. It provides a framework in which voice traffic flowing on an IP network is given priority for processing. The CIX supports IEEE802.1p and Differentiated Services “Diffserv” priority control protocols- selectable. In order to have priority control processing work accurately, network equipment (router, switch, etc.) must support this function and appropriate service must be ordered from the ISP provider or carrier.

### QoS Measurement

eManager can measure the IPT QoS parameters listed below:

- Packets (sent/received)
- Delay (msec.)
- Jitter (msec.)
- Loss (%)



## Analog CO Line Interface Compatibility

To provide optimum voice quality of IP telephones and Strata Net IP networks on Strata CIX systems, there are some compatibility requirements that must be followed when using analog CO line cards in the system.

- Toshiba highly recommends only using RCOU3A, RCOS3A, BCOCIU1A, BCOCIS1A, REMU2A (two-wire/four-wire), REMU1A (four-wire), RDDU2A, and RGLU3A analog CO line interfaces in IP phone and Strata Net IP applications. These circuit cards provide optimum speech quality for Toshiba IP telephones.
- Do not use RCOU1A, RCOS1A, REMU1A (two-wire), RDDU1A, RGLU1A, or RGLU2A analog CO line interfaces in IP telephone applications. These circuit cards will work, but will cause IP telephone users to experience unacceptable voice quality and echo return loss.
- CIX40 Base cabinet CO lines, GCDU1A, GCDU2A and GCOCIH1A circuit cards provide optimum speech quality for Toshiba IP telephones.

## Power Over Ethernet

**System Availability:** All systems

Toshiba has a strategic relationship with SMC to re-sell the 24-port, 802.3af certified SMC6824MPE PoE switch (shown right) through authorized Toshiba dealers.



**Figure 25 SMC6824MPE PoE Switch**

The SMC6824MPE PoE switch is sized and priced to fit well with Strata CIX systems to serve applications in which customers want to power their IP telephones over Ethernet, instead of using local power with each IP telephone. This switch works with the IP5000-series and IPT 2000-series telephones.

### Notes

- The 5000-series and 2000-series IP telephones require local power for operation unless connected to a LAN that has been equipped with special equipment to provide telephone PoE. The AC adapter supplied with it powers the telephone and is included in the price.

## Toshiba SoftIPT IP Telephone

**System Availability:** All systems

The Toshiba SoftIPT™ is an IP telephony client that works with a wired or wireless (Wi-Fi) tablet, laptop or desktop PC, and PDA. The Toshiba SoftIPT integrates the power of a PC with all of the features available on a IPT3000-series telephone, except background music.

With the Toshiba SoftIPT installed on a Wi-Fi laptop PC, users can have true mobility with access to voice mail, programmable feature buttons, and a directory that works with Microsoft® Outlook®.

The Toshiba Soft Phone works on desktop or laptop PC with Microsoft Windows Vista, Windows XP and Windows 2000 / 2003 operating systems (OS). When using an Intel PC, the echo cancellation feature is supported on all these operating systems.

The SoftIPT Version 3.0 has a look similar to 5000-series telephones (shown below) and has some very useful enhancements. Note that version 3.0 software is only for PCs and not PDAs and does not support Windows 2000. SoftIPT on a PC integrates the power of the PC with most of the features available on an IP5000-series telephone (see [Figure 26](#)).

The features supported by SoftIPT Version 3.0 are:

- Self-labeling feature keys
- User control over feature button labels
- Shift key toggles the LCD screen between flexible key 1~10 and flexible keys 11~20

A mouse or stylus is used to click or select the buttons. The Call button operates the same as the digital-series telephone Spkr button. Additionally, there are multiple feature buttons that can be customized from telephone programming mode.

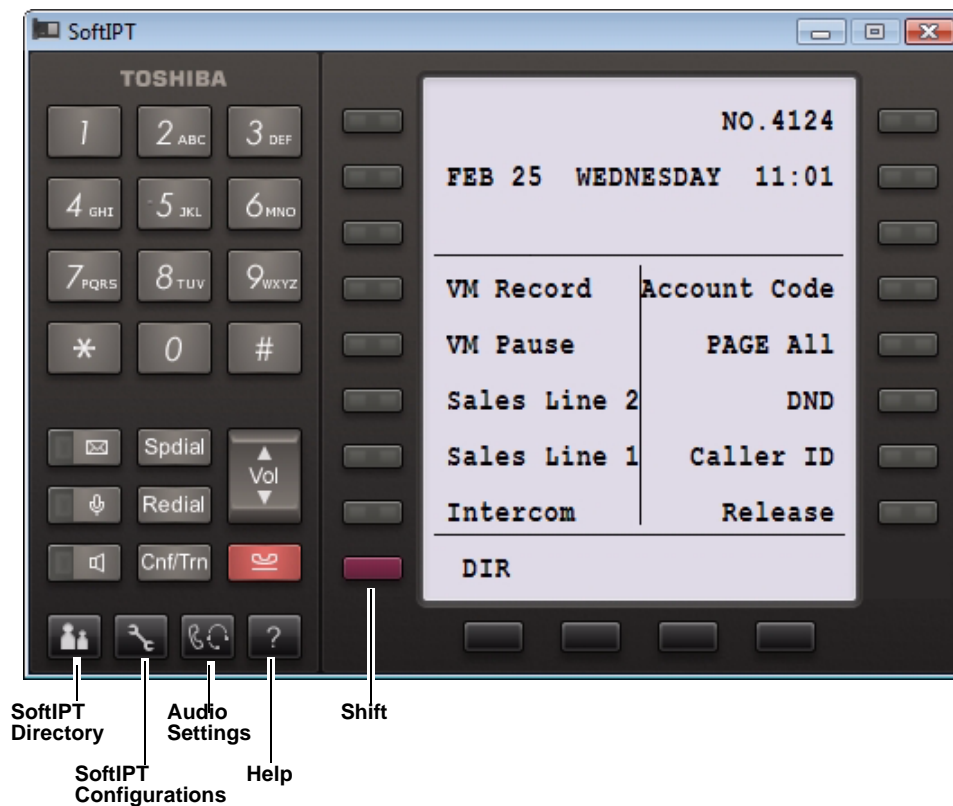
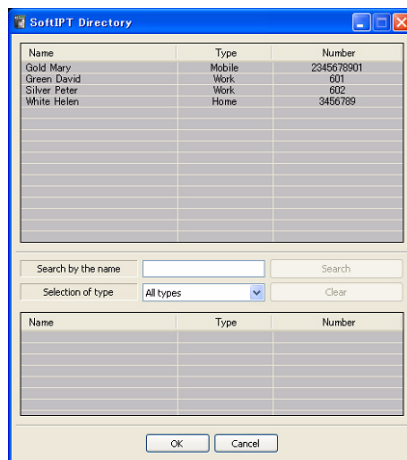

Figure 26 Toshiba SoftIPT 3.0 Sample Screen

With Microsoft Outlook, you can create a directory for the SoftIPT. Once a directory is created, the user can click on a name in the directory to automatically dial their number (see [Figure 27](#)).



**Figure 27** Example of SoftIPT Directory

The SoftIPT can be connected to the Strata CIX system several different ways:

- Intranet – A wired or wireless PC can connect to the office LAN that connects to an IP telephone that connects to a MIPU / LIPU / GIPU / GIPH in the Strata CIX.
- Internet – A wired or wireless PC at a remote site can connect to a Cable or DSL modem, to an Internet Service Provider (ISP), to a router, to the MIPU / LIPU / GIPU / GIPH in the CIX (see [Figure 28](#)). (For additional connection examples, refer to the *Strata CIX I&M manual – IPT Chapter*.)
- Wireless – The wireless PCs, such as the Toshiba Pocket PC or Toshiba Tablet PC need a Wi-Fi system that uses the 802.11b standard. The SoftIPT wireless units can operate within 300 feet of an access point (dealer-supplied or use existing).

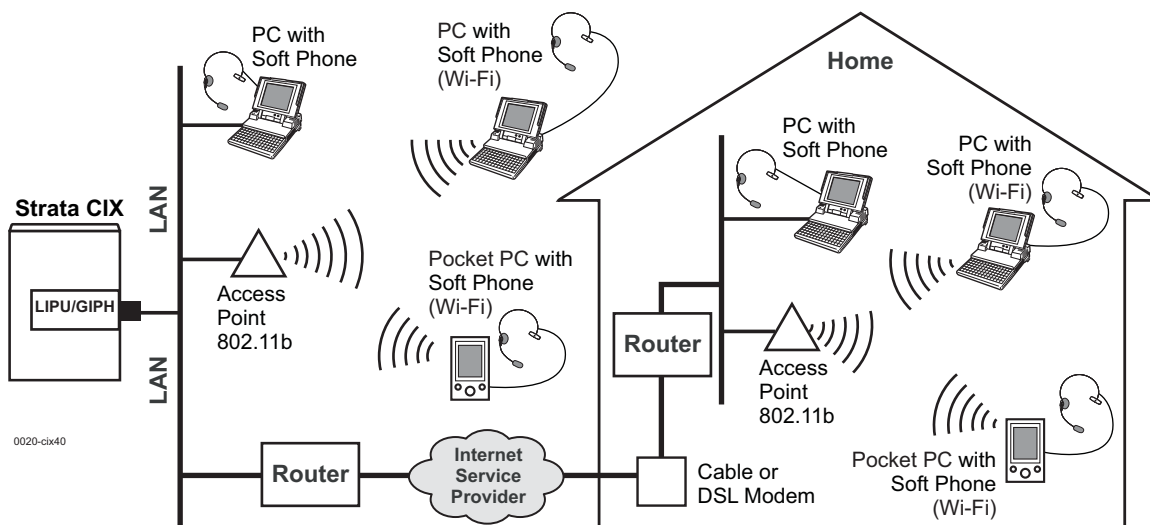

**Figure 28** SoftIPT Internet Connection

## Licensing

Refer to “[Strata CIX Software License Requirements](#)” on page 173.

# Private Networking Over Internet Protocol

## System Availability: All systems

Strata Net CIX multi-system networking can be implemented over an IP network using Strata CIX systems with MIPU / LIPU / GIPU / GIPH IP interface circuit cards. This feature offers the same connection service as ISDN dedicated lines with the Strata Net protocol on the public network. Strata Net IP, does not support modemed data signals, such as modem signal and G3 fax because these signals require very low jitter and low delay on the networks.

The MIPU16 / LIPU can be configured for up to 16 channels in system programming. The MIPU24 can be configured to 24 channels. Adding the LIPS to the LIPU enables you to configure the system to 32 channels. The GIPU / GIPH can be configured to 8 channels. CIX Strata Net private networking over IP can support up to 128 separate nodes.

For bandwidth requirements, refer to the section [“Strata Net IP and IPT Bandwidth Requirements” on page 171.](#)

Refer to [“Analog CO Line Interface Compatibility” on page 125](#) if you are planning to mix analog and Strata Net IP circuit cards in the same Strata system.

MIPU / LIPU / GIPU / GIPH interface parameters include:

- 100Base-TX: Automatic recognition and switch
- Transmission: TCP/IP, UDP/IP
- Protocol: Based on IP QSIG (ECMA-336), NAT compatible
- Protocol: RTP/RTCP for voice transport
- Voice coding: G.711, G.729A, selectable
- Priority process: Diffserv/IEEE802.1p

An example of Strata Net IP networking is shown below.

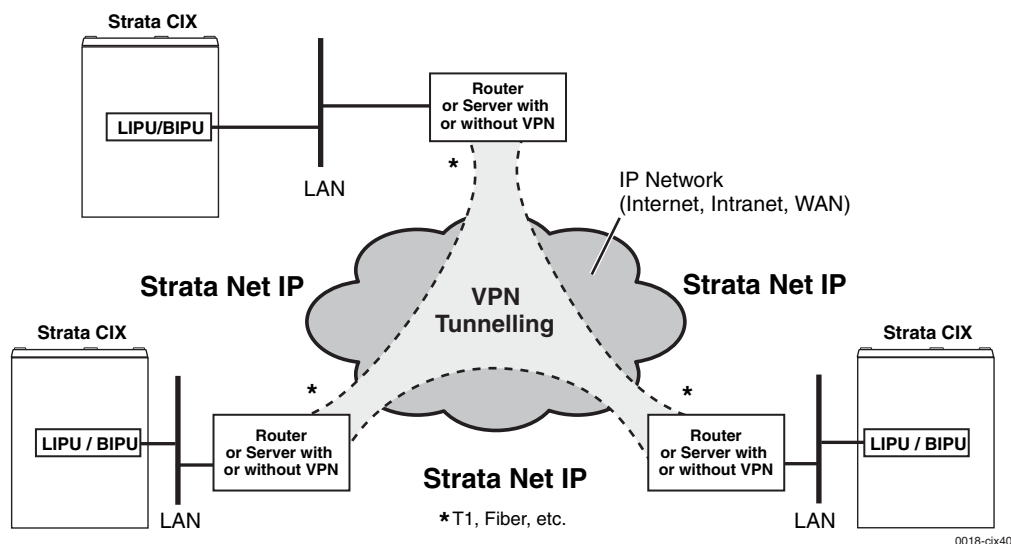

Figure 29 Strata Net IP Example

# SIP Trunking

SIP Trunking allows the CIX to get PRI like services from an Internet Telephony Service Provider using Session Initiation Protocol.

Toshiba implements SIP trunking using the MIPU/GIPU card. The MIPU/GIPU is designed from the ground up as a VoIP card able to support IP stations, Strata Net IP, and SIP trunking. With the SIP Trunking capability of the new MIPU card, companies do not have to purchase different types trunk cards and the bundles of physical wires to host Analog, PRI and BRI trunks. Companies are able to leverage their existing Toshiba CIX R4.x (and later) PBX systems with just the purchase of MIPU/GIPU cards, an update to R5.10MS17 software, and corresponding license. SIP Trunking simplifies IP PBX trunking capability by replacing all the traditional PSTN lines with one SIP Trunking device hosted by SIP Trunking provider on the internet.

MIPU interface parameters include:

- CIX Hardware: CIX40, CIX100, CIX200, CIX670, and CIX1200
- CIX Software: R5.10 MS17 or higher
- MIPU: MIPU01\_07 or higher
- eManager: V5.10 A08 or higher
- Service provider: Contact Toshiba Sales Applications Desk
- Soft Switch: Contact Toshiba Sales Applications Desk
- License: LIC-CIX-SIPT-CH

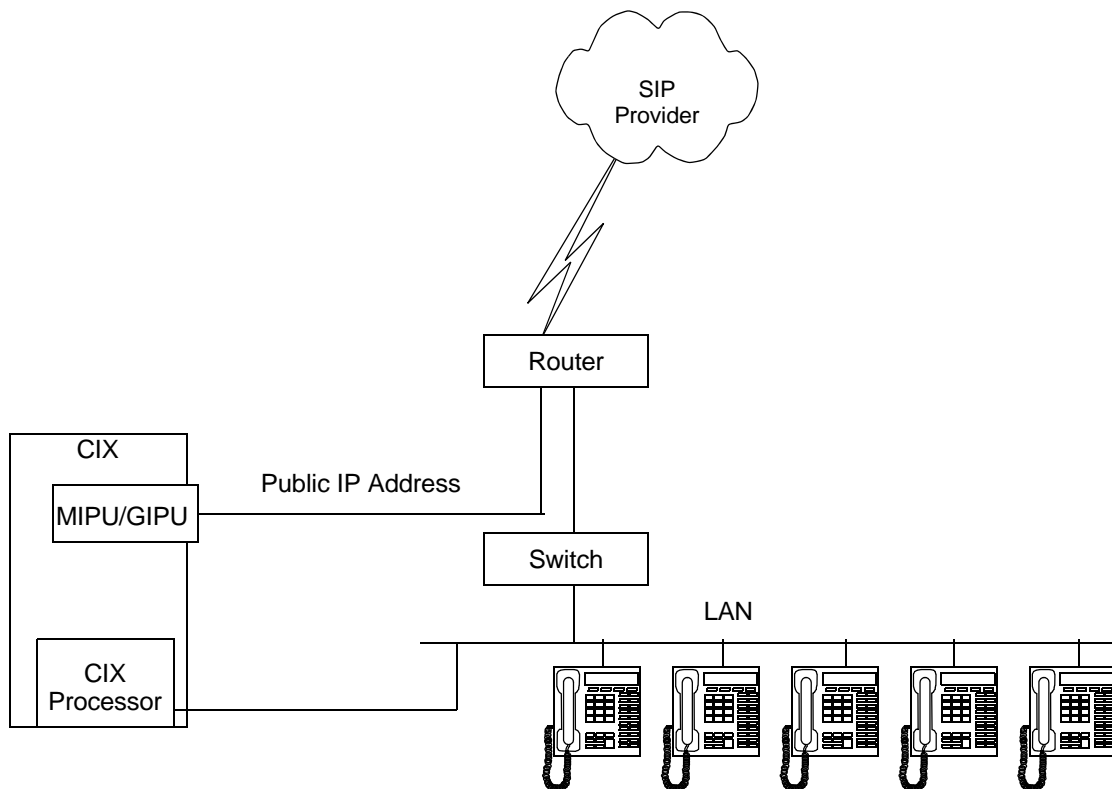

Figure 30 SIP Trunking Example

## Integrated Services Digital Network (ISDN)

### System Availability: All systems

ISDN is a set of integrated telecommunications services, available over the public telecommunications networks. ISDN makes it possible to send, receive and modify information using telephone lines in ways that were not previously possible, such as:

- Dynamic use of individual or groups of standard (POTS), DID, Tie, FX, WATS, 800 lines on an as-needed basis
- Much faster call setup and data transfer up to 128Kbps
- Multi-purpose line use, including sharing lines for voice, data, fax, and video
- DID functionality based on the number dialed; without needing to reserve a block of numbers
- 2-B channel transfer: Allow two external PRI line calls connected to a station conference to be released from the CIX and reconnected by the PSTN when the station drops out of the conference. Requires special ordering from the ISDN provider. Requires National ISDN protocol.

ISDN service comes in two forms:

- **Primary Rate Interface (PRI)** supports simultaneous voice or data connections (eight, 16 or 23). PRI is similar to digital T1 service and uses two pairs of wires from your phone company. The RPTU circuit card supports PRI on the Strata CIX100, CIX200, CIX670, and CIX1200.

## Least Cost Routing (LCR)

### System Availability: All systems

Least Cost Routing chooses the most appropriate route over which to connect an outgoing call based on the following:

- Dialed Digits
- Time of Day
- Type of Day (Business, Weekend, Holiday)
- LCR group of the caller

The combination of routing tables, indices, route definitions and time-of-day qualifiers can produce up to 75 million combinations. Routing changes automatically for each type of day, according to the time of day. This schedule is independent of the Day/Night mode schedule which applies to ringing and CO assignments.

# Line Buttons

Telephone buttons that are used for making and receiving outside calls are referred to as Line (or CO Line) buttons. (For information on various [DN] buttons, refer to “[Directory Numbers](#)” on [page 109](#).) The Strata CIX supports the following types of line buttons:

## CO Line Buttons

**System Availability:** All systems

Smaller systems have traditionally provided the direct appearance of the CO lines on the telephones where maximum visibility of the line status, flexible ringing assignments, and informal call transfers associated with key telephone systems may be implemented.

## Pooled CO Line Button

**System Availability:** All systems

Pooled Line Group buttons enable a group of CO lines to “appear” under one button. Pooled and single appearing line buttons are designed for use with loop and ground start lines, not Tie, DID, DNIS or ANI lines.

## Group CO Line Button

**System Availability:** All systems

Group CO line buttons are like individual CO line buttons except these buttons represent all the lines for a particular ISDN Channel Group. This enables ISDN channels to operate similar to analog CO lines on a key telephone system. These buttons may have appearances on multiple telephones providing call coverage across several telephones. Multiple appearances of the same Group CO line button is possible on each phone to allow multiple call handling for that group from each station.

# Live System Programming

**System Availability:** All systems

Programming the Strata CIX from an on-site or off-site location does not interrupt the operation of the system in most cases. It is interrupted for hardware upgrades.

# Lost Call Treatment

**System Availability:** All systems

Lost Call Treatment provides the CIX a mechanism for terminating calls that cannot be terminated with the usual calling patterns. One scenario would be a call that is recalled to a station, the station user is no longer there to answer the recall and no forwarding pattern is programmed. The call will ring at the recalled station until the Lost Call Timer has expired after which the system will direct the call to the Lost Call Destination.

# Message Waiting

**System Availability:** All systems

Any station and most voice mail devices can turn on a message waiting indicator for a designated digital or standard telephone station.

## LED Indication

Message waiting lights can be activated when a voice mail message has been left, or they can be turned on by a calling station. The station user can retrieve messages by pressing the button next to the message waiting light or by dialing an access code from a standard telephone.

The telephone main Msg light indicates a message is waiting for the telephone [PDN]. Up to four [PhDNs] per telephone can also have individual MW LEDs assigned to flexible buttons.

## Stutter Dial Tone

Stutter dial tone is also used to indicate a message is waiting or your telephone is in the DND mode. When a station user goes off-hook, two different available stuttered dial tones indicate whether a Message Waiting (MW) or DND condition exists. The MW-stutter dial tone indicates a message is waiting for the station. DND-stutter dial tone indicates DND is set at the station. (DND provides a fast busy tone burst as stutter dial tone.) If both conditions exist simultaneously, the MW-stutter dial tone has priority. This is very valuable to station users that do not have a MW Light Emitting Diode (LED) or DND button LED on their telephone. (See [Table 41 on page 168](#) for details of each type of stutter dial tone.) With Release 1.3 and higher, users can disable (in programming) stutter dial tone for message waiting and when in the DND mode. If stutter dial tone is disabled, they will hear normal dial tone when you go off hook.

# Microphone (External Unit)

**System Availability:** All systems

An external microphone (RFDM) can be connected to the DKT2020-FDSP digital telephone enhancing “full-duplex” operation by virtue of the “superdirectional” characteristic of the microphone. When this option is on, the internal microphone is disabled on all but Voice First Handsfree Answerback calls and OCA calls. The external microphone is powered by the DKT and does not need to be turned off when not in use.

# Music-on-hold

**System Availability:** All systems

Music-on-hold can be derived from a customer-supplied radio, tape player, tuner, CD player or other device to provide music or announcements to parties on hold on CO lines or on [DNs]. With the Strata CIX, you can have up to 15 MOH/BGM sources. Each CO line group and each DID/DNIS number may be assigned a specific MOH source. Stations and network Tie lines can also share a unique MOH source.

# Multiple Call/Delayed Ringing

**System Availability:** All systems

You can assign Delayed Ringing to voice mail and auto attendants. This feature can also be used to ring multiple (25 max.) telephones immediately or with a delay by dialing a group pilot number. Each group member can have Immediate, Delayed Ring 1 or Delayed Ring 2. Delayed Ring times are adjustable (1~180 seconds) for each Multiple Call Group. Multiple calls to digital telephone is supported; however, delayed ring to digital telephones is not supported as of this printing.



# Off-Hook Call Announce (OCA)

## System Availability: All systems

Station users may announce a call when the station they call is busy talking with the handset off-hook. The announcement is only audible to the telephone user receiving the OCA call, not to the other party in the original conversation.

Two different methods of operation are provided – handset or speaker OCA. With handset OCA, the OCA caller's announcement comes in on the telephone handset. With speaker OCA, the announcement comes in on the speaker. Handset or speaker OCA can be set individually for each telephone that must receive OCA calls. Speaker OCA on digital DPs require a BVSU option for DKT3200-series telephones or a DOCA-1A option for DP5000 telephones. Handset OCA has no optional hardware requirement. Speaker OCA on IP5000-series telephones requires an MIPU / LIPU / LIPS / GIPU / GIPH installed in the Strata CIX.

**Note** Each IP5000-series telephone enabled with Speaker OCA requires two IP channels on the same IP interface card but only one IP endpoint license. The OCA IP channel can be shared by all IP5000-series telephones and is only used while the OCA call is active.

When a busy telephone receives a handset OCA call, replying confidentially to the OCA caller can be accomplished by pressing the Msg button (toggle) to place the original call on hold or holding down the Mic button to make a short reply. In either case, the original caller will not hear the reply to the OCA caller. To reply to a speaker OCA call, the user covers the handset mouth piece and talks back through the telephone microphone.

Any type of telephone can be enabled to originate OCA when calling a busy digital telephone. The feature is activated automatically (optional setting) or manually (Call Completion code – digit 5). Stations receiving OCA must be proprietary digital telephones assigned with OCA-receiving capability in system programming. Standard single-line telephones cannot receive OCA.

Any type of station can make an OCA call, as long as the station has this option enabled in system programming. OCA to DND telephones is allowed only if DND Override is allowed on the called and calling telephones.

**Note** The CIX40 supports Headset OCA on digital and IP telephones, but only supports Speaker OCA on IP5000-series telephones.

# Off-Premise Stations

## System Availability: All systems

Off-premise stations are supported using either standard analog telephones or Toshiba digital telephones. This can accommodate both individual telephones and branch office connections. Off-site standard analog telephones can be part of the system, having access to many of the features offered by the Strata CIX. Each off-site standard telephone station requires a special OPX line from the CO and the RS48 subassembly on the CIX standard telephone interface card. This enables groups of remote workers to use Toshiba digital telephones to have seamless access to the main location's telephone system and voice mail system. Off-premise stations require secondary lightning protectors.

Remote employees have transparent access to all the same capabilities as if they were locally connected to the Strata CIX system. They have can the same ability transmitting voice traffic and digital telephone signaling over the customer's existing Local Area Network (LAN) Wide Area Network (WAN) private IP packet network or the public Internet.

**Note** CIX40 standard telephone ports do not support RS48 which limits OPS telephones to OLI3B (600 ohm) loops.

# Override

**System Availability:** All systems

## Call Forward Override

Stations with this feature will not forward when they call stations that have System or Station Call Forward activated. This applies when using the telephone dial pad or [DSS] button to make a call. It also applies to [DSS] buttons on DSS consoles or add-on modules associated with the Call Forward Overriding telephone.

## Class Of Service Override

By dialing a Class of Service Override (COS) code, a user can change a station's class of service to one associated with the override code. When the call is terminated and another is attempted from the same station, the original Class of Service is applied. This allows selected users to override toll restriction or other restrictions that are placed on any telephone in the system.

## Do Not Disturb (DND) Override

A privileged caller may invoke the DND Override feature after dialing an internal station and receiving a DND indication. If that privilege is granted to the calling station and the called station permits its DND to be overridden, the call will ring on that phone.

## Executive Override

Stations with this feature allowed by COS can enter any conversation in the system by dialing a 3 or pressing a Feature Prompting Soft Key after dialing a busy station. An optional warning tone notifies the parties that another party is about to conference into their conversation. Executive Override can be blocked selectively to any station in system. Executive Override must be allowed in system programming for the called and calling station.

The Do Not Disturb feature can also be used to block Executive Override; however, stations that are allowed DND Override can use Executive Override on stations in the DND mode. The Privacy button does not block Executive Override.

## Privacy Override

Privacy override controls the ability of multiple station users with a shared (common) Line or [DN] button appearance to join in each other's conversation by pressing the busy button appearance. A station must be programmed with Privacy Override to permit the intrusion on a shared Line or on [DN] buttons.

In the case where Privacy Override is normally allowed, a telephone can have a "Privacy" button to block Privacy Override (intrusion) to the call. The Do Not Disturb feature does *not* block Privacy Override. In the case where Privacy Override is not normally allowed, a telephone can have a "Privacy Release" button to allow intrusion to the call by any station with the shared button appearance. (See "Privacy" for more information.)

# Paging

## **System Availability: All systems**

The Strata CIX has a paging interface that supports a Toshiba External Speaker (BESCB) or a customer-supplied amplifiers and speakers for Paging, Night Ringing over Page, and BGM applications. Users can access any of the Paging options by dialing access codes or by using a programmed One Touch button.

## **Telephone Group Paging**

Paging is activated from an extension by specifying a Paging Group. Paging can be broadcast through digital telephone speakers and external paging devices simultaneously. The system supports up to 16 or 24 telephone page groups with up to 120 (CIX200), 72 (CIX100), 120 (CIX670) or 120 (CIX1200) telephones per group. Standard telephones cannot be members of a page group.

## **External Speaker Page Zones**

The Strata CIX supports eight different paging zones for external speakers. Users can access zones by dialing an access code plus the zone or pressing a One Touch button. The zones are composed of customer-supplied speaker(s) and amplifier(s). One BIOU supports up to four page zone interfaces, a second BIOU is required for 5~8 zones.

## **Emergency Page**

Designated stations can be permitted to place an Emergency Page to ensure they can reach all concerned with an important announcement. An Emergency Page is one that will supersede any current page to allow this privileged station to take over the paging apparatus. Like other forms of paging, an Emergency Page can be an All Page or directed to a specific Page Group and External Page Zones.

Each of the 16 or 24 Paging Groups supports up to 32 devices. Emergency Page groups follow the regular Group Paging. The list for Emergency All Call Paging is a separately defined list from regular paging. An emergency page may be answered in the same manner as a regular page.

## **Night Ringing Over Selected Page Zones**

Lines can be programmed to night ring over eight selected Page zones via customer-supplied paging equipment. Up to two BIOU circuit cards can be installed to connect external paging or night ringing equipment. Each BIOU supports up to four page zones.

## Power Failure Protection

**System Availability:** All systems

The Strata CIX has important optional capabilities that keep the system operating when commercial AC power is interrupted.

### Power Failure Transfer

The Strata CIX can immediately switch loop start analog CO lines directly to dedicated standard telephones (customer-provided 2500- or 500-type) for incoming and outgoing calls in the case of a commercial AC power failure. The transfer is automatic with no manual transfer procedure required. During normal operation with AC power, the Power Failure telephones function with all Strata CIX features available to a normal standard telephone. This feature requires a Toshiba supplied external unit called the Power Failure Transfer Unit (DPFT-102) on CIX100, CIX200, CIX670 and CIX1200 (the CIX200 can also use the Toshiba supplied LPFU1A). The CIX40 provides one built-in PFCT relay for CO Line1 and the base unit standard telephone circuit.

### Reserve Power Battery Backup

An Uninterruptible Power Supply (UPS) is required for power backup on a CIX200. The UPS is similar to the ones used for Computer systems and Networking equipment. Two or four 12-volt gel-cell, maintenance-free batteries can be connected to the CIX40, CIX100, CIX670, and CIX1200 system power supplies for system battery backup (80 amps./hours max.). The CIX670 and CIX1200 system power supply is standard-equipped with a battery charger and the batteries continuously trickle charge to capacity while electrical power is present. The CIX100 power supplies must be equipped with the optional ABCS battery charger to charge reserve power batteries.

If the AC power fails, the Strata system automatically switches over to battery power without any interruption in operation. Calls in progress are not interrupted. Battery operation duration depends upon the condition and ampere hour rating of the batteries and the system load. However, the minimum battery operation time would be several hours. Connection of reserve power batteries must be made when commercial AC power is available.

## Privacy

**System Availability:** All systems

Privacy prevents intrusion on calls that appear on shared (common) [DN] or line buttons. If a telephone has a call on a [DN] or line button that appears on other telephones, the other telephones cannot intrude on the call by pressing the shared button unless the intruding telephone has the Privacy Override feature or the telephone with the call activates the Privacy Release button.

## Remote Update

The remote program update is administered using the eManager Administrator tool to update the Strata CIX software remotely over a TCP/IP or Modem connection. The SD or SM card must be installed on the Strata CIX processor to allow remote updates.

# Repeat Last Number Dialed

**System Availability:** All systems

This feature enables a digital station to automatically redial the last number dialed from their station by selecting an outgoing line and pressing the Redial button or by dialing an access code. Digital key telephones have a fixed Redial button for automatic redialing of the last number dialed.

## Ringling

**System Availability:** All systems

### Ring Over Busy

When a digital telephone is busy on a call and then receives an internal or external call on an idle [DN] or line button, the button will automatically flash and ring with Ring Over Busy tone. The tone burst can either be sent two times (three seconds apart) or repeated continuously every three seconds or not sent as a station option. To answer a Ring Over Busy call, the user can hold, transfer or disconnect the existing call.

On Voice First calls to a busy telephone that has an idle [DN], the caller will get busy tone. The caller can then dial the digit 1 to cause the idle [DN] to Ring Over Busy.

### Ringling Cadence

With Release 1.3 and higher, you can choose between two different ringling cadences for standard telephone circuits in programming. This option is necessary to accommodate some voice mail and/or auto attendant devices. This is a system wide option that allows external calls to ring with the traditional one sec. on./three sec. off cadence or optionally with a faster cadence of 0.4 sec. on./2 sec. off. This option does not apply to digital telephones. If ringling cadence is used, Centrex ring repeat must not be used.

### Delayed Ringling

See [“Delayed Ringling” on page 106.](#)

### Distinctive Ringling

See [“Distinctive Ringling” on page 110.](#)

## Speed Dial

### System Availability: All systems

This feature, sometimes known as automatic dialing or one-touch dialing, enables the customer to assign dialing codes to telephone numbers that are frequently called. Strata CIX offers three forms of Speed Dial: System Speed Dial (up to 800 max. per system), Station Speed Dial (100 max. per station), and One Touch buttons. Station Speed Dial numbers and One Touch buttons are unique for each station and cannot be used by other stations. System Speed Dial numbers can be used by any station in the system.

To dial System and Station Speed Dial numbers, the user presses the Spdial button and then dials the appropriate three-digit code for the telephone number to be dialed. To dial a telephone number assigned to a One Touch button, the user simply presses the One Touch button. Users can program Station Speed Dial and One Touch buttons from their telephones.

CIX eManager is required to program System Speed Dial numbers and can also be used to program Station Speed Dial numbers, but not One Touch button numbers. Each Station and System Speed Dial number can be assigned a nine-character name using CIX eManager. This name appears in the DP5000-series LCD when using System Speed Dial and Personal Speed Dial directories (accessed through DIR softkey).

## One Touch Buttons

One touch buttons enable users to store speed dial and custom feature access sequences on a single button. When this button is pressed, the stored number is dialed or the feature is accessed.

You can store frequently dialed numbers, such as three-digit System Speed Dial codes, onto a One Touch button. This eliminates the need to enter the three-digit code to dial a System Speed Dial number. Complete telephone numbers up to 32 digits can also be stored on a One Touch button.

These buttons make it easy to access features that usually require pressing multiple buttons and/or dialing special access codes. For example, a user may have to dial an access code (#31) plus a zone number (5) to page the warehouse. This sequence can be set on a One Touch button labeled "Page Warehouse." Another button can be set to page a particular group of telephones.

The One Touch button also has a "stop" function that can be entered between two numbers, such as a telephone number and security code. When the One Touch button is pressed, it can speed dial a telephone number, then pause (LED flashes). When the call is answered, it prompts for a security code. The user can then press the flashing button and enter the security code. Any number of "stops" can be set to enable dialing multiple numbers.

Multiple feature buttons such as Cnf\Trn, [DN], CO line, etc., can be set on One Touch buttons to allow multiple button presses to be stored under one button. This enables tandem line connections and other call setup sequences to be dialed easily by pressing one button.

## Station Hunting

### System Availability: All systems

A series of Directory Numbers (DNs) can be organized in groups in such a way that if a called [DN] is busy the call will try to ring another [DN] in the group. If that [DN] is busy it will hunt to a third [DN], etc. Telephones in the same department, voice mail ports and boss/secretary call coverage situations are typical applications for hunt groups. Hunt group members can remove themselves from the group by placing their station into the Do Not Disturb mode. The system supports three types of station hunting:

## Serial Hunting

In this type of hunt group, calls hunt [DNs] in a series from first to last in a specific order. When any [DN] in the series is called, the system will ring the first idle [DN] in the series, starting with the called [DN], hunting to the last [DN] in the series. As an option, this type of hunt group can have a unique Pilot [DN] assigned to it. When callers dial the Pilot [DN] to reach a telephone in the group, calls will hunt all [DNs] from first to last.

## Circular Hunting

In this type of hunt group, calls hunt [DNs] in a series in a specific order; however, the series forms a loop, which enables the last [DN] to hunt to the first [DN]. When any [DN] in the series is called, the system will ring the first idle [DN] in the series, starting with the called [DN], hunting to all [DNs] in the series. As an option, this type of hunt group can have a unique Pilot [DN] assigned to it. When callers dial the Pilot [DN] to reach a telephone in the group, calls will hunt all [DNs] from first to last.

## Distributed Hunting

This type of hunt group always has a unique Pilot [DN] assigned to it. Callers dial the pilot [DN] to reach a telephone in the group. Calls hunt in such a way so as to distribute the calls evenly to each [DN] in the group. Hunting rotation always starts in sequence with the [DN] that follows the [DN] that received the last call – even if all other [DNs] are idle.

## Camp on to Hunt Groups

On incoming CO line calls to busy hunt groups, the caller automatically camps on to the called [DN] or Pilot [DN] and the caller receives ring-back-tone.

On internal calls to busy hunt groups, the caller may get busy tone. The caller can then dial a digit to initiate Camp On-Busy to the called, busy [DN] or the Pilot [DN], if used. As an option, for each hunt group that uses a Pilot [DN], calls will automatically camp on to the called Pilot [DN].

With the Automatic Camp On option, the caller does not get busy tone, instead the caller receives confirmation tone followed by ring-back-tone. When using hunt group Pilot [DNs], camped on calls queue onto all [DNs] in the group and will connect to any [DN] in the group that becomes available. When not using Pilot DN's, Camp On is only applied to the called [DN].

When more than one party is camped on (queued) to a hunt group, the party with the highest Queuing Priority Level (QPL) will be connected first when the destination becomes available. If the parties have the same QPL, the longest waiting call will be connected first.

# Station Message Detail Recording (SMDR)

**System Availability:** All systems

For each incoming, outgoing or tandem call, the Strata CIX can generate a record that includes details of the call, including the originating station or trunk, the start time of the call, its duration, authorization codes, etc. If a station user dials "911," the Strata CIX will also generate a record at the beginning of the call as part of its internal notification that an emergency call is in progress. SMDR requires an optional BSIS or network interface circuit card and a connected Call Accounting system.

For [Network SMDR](#) and [Centralized SMDR for Systems in a Strata Net Network](#), refer to [page 142](#).

# Strata Net Multi-system Networking

## System Availability: All systems

Strata Net is a private networking application based on QSIG, an international standard for inter-connecting PBXs. Strata Net delivers a rich set of calling features across multiple CIX systems throughout the enterprise. Users benefit from transparent dialing and simple feature operation.

Advanced networking features include Centralized Voice Mail, Centralized Attendant, Network SMDR and Station DSS button appearances across all nodes. Alternate Routing provides for toll bypass configurations and automatic recovery from network disruptions.

Strata CIX systems are interconnected with DS1 (T1) circuits to provide ISDN-type inter-connectivity.

Strata Net IP also provides full Strata Net connectivity and capabilities over an IP network (VPN WAN, Internet, intranet Frame Relay, fiber, or wireless).

Up to 128 nodes can be accommodated within the Strata Net numbering plan. Up to four nodes connected in tandem can give satisfactory performance with regard to latency. As with any network design, transport delay, speech volume and other issues must be carefully considered.

You can set up network DN tables across nodes. Through system programming, you can attach a node ID to non-redundant DNs, PhDNs and Pilot numbers. This enables someone in one node to call an extension in another node without having to dial the node ID number. The caller dials the extension and the system automatically routes the call to the node in which the called extension is located and rings the called extension.

## Coordinated Numbering Plan

### System Availability: All systems

Strata Net can be configured to allow users to call each other across network nodes with simple network directory numbers. This eliminates the user's need for access codes and network maps. Calls that encounter a busy or unanswered destination can be forwarded to any node in the network, including a centralized voice mail system or attendant.

## Strata Net Basic Call Control

### System Availability: All systems

The Strata CIX conforms to the QSIG standard for Basic Call Control. This is the basis for all Strata Net connectivity and interoperability with PBXs from other manufacturers. Basic Call Control provides for connection, dialing, identification of calling and called parties' names and numbers and message waiting indications among other features.

**Important!** *Toshiba does not guarantee interoperability with other manufacturer's products: only conformance to the standard.*



## Alternate Routing

**System Availability:** All systems

Each Strata CIX can be programmed for thousands of routing patterns for Strata Net alone. This allows the creation of networks in which calls can be automatically re-routed around network disruptions. Centralized facilities and features can continue to work and users will be unaware of problems while they are being repaired.

Alternate Routing also permits Toll Bypass in which Strata Net can be used to deliver a public call from a point in the network where toll charges are minimized. Such a scheme is known as “Hop Off” for the ability of the private network to determine the point at which the call will hop off to the public network.

## Centralized Attendant

**System Availability:** All systems

One attendant can serve an entire Strata Net. Station users only need to dial “0” to reach the centralized attendant regardless of the node in which they reside. The attendant can reach any station in the network using its Network Directory Number. Trunks attached to any network node can be programmed to terminate to the centralized attendant and their source and calling party information will be delivered to the attendant’s display. The BLF appearances of all stations from all nodes can appear on the centralized Attendant Console.

## Telephone DSS Buttons

**System Availability:** All systems

Telephone DSS buttons can appear across the Strata Net network. This enables a user’s DSS button to function in all nodes in a CIX network. The DSS function works within or across a network.

## Centralized Voice Mail

**System Availability:** All systems

Requires Strategy ES or iES Release 4 or higher. A voice mail system attached to any Strata Net network node can serve users throughout the enterprise. Unanswered calls will be forwarded to the voice mail, the source and calling conditions identified and the appropriate voice mailbox greeting will be played. The voice mail system can control message waiting indications throughout the network as messages are left and retrieved. A single network can even support multiple centralized voice mail systems with each station being programmed for the appropriate system. Record to voice mail and voice mail soft keys are available across all network nodes from a single Strategy R4 ES or iES voice mail system.

## Network SMDR

**System Availability:** All systems

### Distributed Network SMDR for Systems in a Strata Net Network

An external Strata Net call will generate a call record at the terminating node for that call. Transit nodes will not generate records. The records can be stored in customer-supplied external buffers at each node. Third-party polling call accounting software can gather and organize the data from multiple nodes. Local buffering provides survivability in the event of network disruption.

### Centralized SMDR for Systems in a Strata Net Network

**System Availability:** All systems

The SMDR information from each Strata CIX system, connected over a TCP/IP Strata Net network via the CIX processor LAN interface jack can be sent to a Centralized SMDR system. Separate SMDR equipment is not required at each node.

Dealer supplied third-party Call Accounting software can be located on a single Call Accounting Server that can receive SMDR call data from each Strata CIX node. Users having dealer supplied Call Accounting client software can retrieve reports from the server from any location.

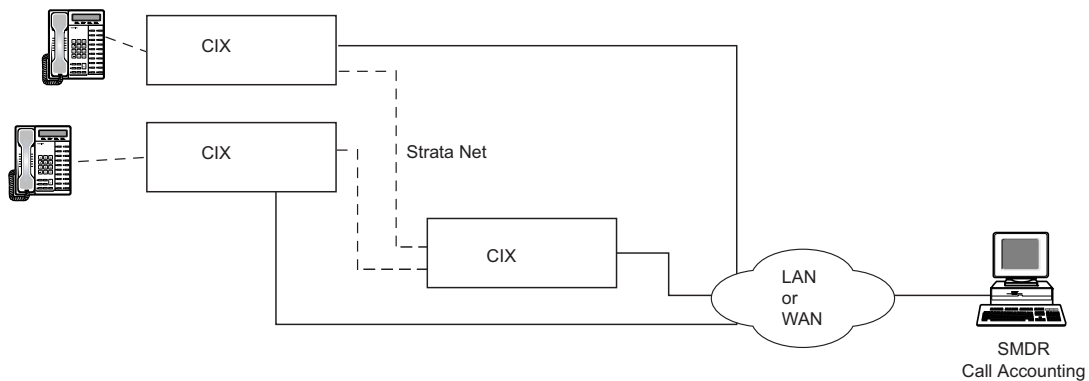

SMDR RS-232 interface (BSIS) continues to remain an SMDR interface option; so customers that use Call Accounting software that only supports RS-232 interface can continue to use it with Strata CIX Release 4.1.

# System Fault Finding and Diagnostics

## System Availability: All systems

The Strata CIX can detect problems in the system. These conditions can be detected, alerted, logged, and traced. Strata CIX includes many useful diagnostic tools.

## Alarm Indication of System Faults

Visual Alarms are presented to CIX eManager.

## Secure Digital Card

This is a flash memory card that is commercially available in retail stores. The Strata CIX uses the Secure Digital card to store all error, trace logs and a backup copy of the system operating software and the customer database. Toshiba ships 512MD Secure Digital cards with each CIX40, CIX100, CIX670, and CIX1200 system package. The Secure Digital card is inserted into a socket on the CIX processor. The CIX processor creates directories and files onto the card for maintenance functions. Using eManager enables moving, copying, or deleting these files without having to remove the Secure Digital card from the CIX processor. With eManager, this works locally or remotely. Secure Digital files can also be managed by removing the Secure Digital card from the CIX processor and inserting it into a PC Secure Digital card read/write adapter. The CIX200 processor, the LCTU1A, uses a SmartMedia flash memory card.

The Strata CIX Release 3.10 and below processors and all CIX200 LCTU1A processors use the SmartMedia card.

## Fault Detection and Error Logs

The Strata CIX detects and logs abnormalities that it encounters during operation. All error and trace logs are stored on the Secure Digital or SmartMedia card on the system processor and are monitored by eManager. Examples are trunk failure detection and auto busy-out, digital telephone port failure detection and auto busy-out plus error log, Expansion Cabinet power supply failure alarm and error log, etc.

## Event and System Administration Logs

Events such as station buttons pushed or lines accessed are stored in an Event Log. All actions made by the System Administration user are logged. Both logs may be called up at a later time.

## Automatic Fault Recovery

The system can automatically correct certain conditions detected during operation. This enables the system to continue operating normally without requiring correction.

## System Trace

The system records telephone key strokes and other high level events and presents the data in a format understandable and useful to the field technician for troubleshooting purposes. The system also records more detailed data useful to a software support engineer.

## Manual Test

The maintenance technician can perform certain test functions using eManager to determine proper operation of the system.

## Backup and Restore

The customer database can be backed up and restored using the SD flash memory card. The customer database is a file that can be stored on a SD card, transferred to the PC hard drive, e-mailed, etc. The backup and restore functions can be performed locally or remotely.

## Maintenance and Administration

The eManager terminal can be connected directly to the Strata CIX or via the customer's LAN as well as remotely over the Internet and via modem over the public network. The Strata CIX processor comes standard with a network interface port and a built-in modem.

## Software Upgrade

The Strata CIX operating software can be upgraded using the Secure Digital or SmartMedia card or by downloading it from a remote location. The operating software is a file that can be stored on the Secure Digital/SmartMedia card, transferred to the PC hard drive, e-mailed, etc.

# Transfer

**System Availability:** All systems

Transfer is the ability to redirect a connected call to new destination. The Strata CIX provides three means of transferring a call and three means of terminating transferred calls, depending on the calling state of the destination. The transferring features and the terminating features may be used in combination to serve most needs that arise.

## Transfer with Camp On

This feature enables the transfer of a call to a busy destination. The transferred party automatically camps on to the busy destination when the transferring party releases the call.

## Transfer Immediate

Call Transfer Immediate simplifies the transfer of calls for users of digital display telephones. With a conversation in progress, the display phone user presses the **TRNS** Soft Key and dials the transfer destination. The calling party is placed on Consultation Hold, the call immediately transfers and the transferring phone returns to idle. This feature does not apply to network calls.

## Transfer Privacy

An outside call that has been transferred can only be answered at the station to which the call has been transferred. Another station cannot pick up the transferred call using a common CO line button unless it is another station using the Directed Call Pickup feature or a station that has a [DN] appearance of the "transferred to" [DN]. A flashing red LED indicates the call is transferred. Privacy for transferred calls can be disabled in programming.

## Transfer (Screened)

The transferring party can talk privately with the receiving party before connecting the party to be transferred. While that conversation is going on, the transferred party is on Consultation Hold listening to Music-on-hold. When the receiving party agrees to accept the call, the transferring party can use the switch hook or feature button to include the original party in the conversation. At this point, the transferring party can hang up and the other two parties remain connected.

## Transfer (Unscreened)

Unscreened Transfer allows the transferring party to exit the connection before the transfer destination answers. After the destination answers the call, the system treats it as a regular call. If the destination does not answer the call within the predetermined time of period, the transferring party is recalled.

## Transfer to Voice Mail

See [“Direct Transfer to Voice Mailbox” on page 151.](#)

## Music or Ringing Option

This feature enables ringing or music to be heard by the caller when their call is transferred, depending on system programming.

# Tenant Services

### **System Availability:** All systems

This feature enables one CIX to provide separate service to multiple companies or departments (tenants). PDNs, DIDs and incoming line groups (ILGs) can be assigned to one through eight tenants. Each tenant can have different attendant or night bell assignments for day-of-the week schedules using Day 1, Day 2, or Day 3 modes. This feature is enabled through system programming.

# Traffic Measurement

### **System Availability:** All systems

Technicians and System Administrators can monitor the effectiveness of the system resources for proper traffic balance. These traffic statistics are necessary for the system administrator to both monitor the effectiveness of the system and determine whether the system has enough resources or improper traffic balance. No additional hardware is needed to support Traffic Measurement.

Traffic Measurement setup and reporting is done using CIX system programming commands. Approximately five days of Traffic Measurement reports can be stored on the system SD flash memory card.

The Traffic Measurement is system based. The measurement cannot be set to report per tenant.

## Traffic Reports

New traffic reports include outgoing and incoming trunk group usage, “all circuits busy” reporting DTMF and conference circuits. The reports are stored on the processor’s Secure Digital (SD) or Smart Media flash memory card locally, and reports can also be sent to a remote device over a TCP/IP or RS-232 connection. Traffic reporting is set up based on day of week and time of day. Reports are easy to read, time-stamped files that are generated and sent out hourly. No additional software application is required.

Reports include traffic intensity on incoming/outgoing line groups and system resources such as DTMF and Conference circuit usage. Reports can measure traffic in Centum Call Seconds (CCS) or Erlangs. All circuits busy and Abandoned calls are also reported.

## Uniform Call Distribution

### **System Availability: All systems**

Strata CIX systems have built-in Uniform Call Distribution (UCD) functionality, which provides call flow to distribute calls more efficiently through a call center. UCD enables calls to be answered by the auto attendant, which prompts the caller to dial the correct UCD group number or, calls can ring directly to UCD groups. The call is then sent to the UCD agent or queue if all agents are busy or logged out, but never to a busy number. Incoming calls can also be directed directly to UCD groups without the use of an Auto-attendant.

Calls sent to agents are managed by distributed hunt to find the next available agent. Callers in queue can receive music and announcements imbedded in one of the systems music-on-hold sources, and each UCD group can share or have a separate music source. The announcements must be recorded on the music source. Overflow timing is controlled by a unique overflow timer for each UCD group. Agent log-in and log-out buttons make it easy for agents to sign in and out of the system so that calls can be routed appropriately.

The built-in UCD standard feature is ideal for basic call processing applications not requiring the more robust optional ACD and reporting capabilities available with Strata CIX systems.

## Interaction with Other Features

### **Call Forward, System Call Forward**

UCD calls do not forward per the station’s call forward assignments. Calls routed directly to the agent’s station, not through the UCD pilot, will forward when System Call Forward is set.

### **Do Not Disturb**

If DND is activated while the call is ringing the agent, the ringing tone is stopped. However, queuing or overflow is not executed. On the other hand, if DND is activated on the overflow destination, the call does not overflow.

### **Dialed Number Identification Service**

If the overflow destination is voice mail and the overflowed call is a DNIS call and associated with VM-ID, VM-ID sent to Voice Mail follows DNIS specifications.

## Station Hunting

The overflow destination can be a station hunting pilot or member. The system selects an idle station from the Station Hunting group and terminates a call. If no idle station is found in the station hunting group, the system camps on the call according to the station hunting specifications.

## Offhook Call Announce (OCA), Handset Offhook Call Announce

Even if automatic OCA is set at the originator terminal and the overflow destination is set to allow OCA, the overflowed call does not use OCA.

## Private Networking

The overflow destination can be a station in another node. However, if the overflow destination is an UCD pilot in another node and all agents are in logout, DND or Make Busy state, the call does not overflow and stays in the queue.

## Multiple Calling

If a UCD pilot is a member of a Multiple Calling Group (MCG), the call does not terminate at the UCD agent. If all members are UCD pilots in a MCG, the caller hears ROT.

## Door Phone

If a door phone call comes to UCD, it terminates to an UCD agent according to the hunting rule even if the agent is not logged in.

## Class of Service

Call is queued to UCD, even if caller's Class of Service does not allow the camp on.

## Lost Call Treatment

If a Lost call comes to UCD, it terminates to an UCD agent according to the hunting rule even if the agent is not logged in.

## Intercept

If UCD is assigned as the intercept position, the call terminates to UCD agent according to the hunting rule even if the agent is not logged in.

## Phantom DN

If the phantom DN is assigned to the UCD group, Login/Logout and DND are controlled by the owner of the phantom DN. When the owner logs in, the call can be terminated at phantom DN. If this DN appears on multiple phones, it will ring all phones. However, if no owner is assigned to the phantom DN, the call cannot be terminated at the phantom DN.

## Music on Hold

If a UCD call is camped on to the overflow destination, the caller hears MOH programmed for the overflow destination. When a UCD call is in the UCD queue, the caller hears MOH programmed for the UCD group.

# User Programming Mode

## System Availability: All systems

Digital telephone users can use the programming mode for customizing their Toshiba telephones without the aid of an Administrator or Service Technician. The User Programming mode is accessed with a Program button assigned to a flexible button or through an access code. User Programming enables users to customize these features:

- **Flexible Buttons** – Toshiba telephones have 10, 14, or 20 flexible buttons to which the user can assign any one of approximately 50 different features (DND, ACB, Release, etc.). Once assigned to a button, the feature is accessed by pressing that button. Some buttons have parameters that users can set. These include:
  - **Call Forward** – Users can set the Call Forward (CF) destination and CF-No Answer Timer for the CF buttons.
  - **One Touch** – Users can set speed dial and custom feature access code sequences for One Touch buttons.
  - **Background Music** – Users can select the music source (up to 15 sources) that will play on their telephone's speaker when they activate the BGM button.
  - **Ring tones** – Line and [DN] button ringing tones can be changed to one of four different tones. These tones apply to direct or transferred incoming calls from outside lines, not internal calls.

**Note** Directory number and external line buttons cannot be added or deleted, but their ring tones can be individually changed.

In addition to the Programming Mode, an advanced programming function enables administrators to individually turn On/Off the telephone's beep tone, handset call waiting tone, and microphone background noise cancellation option.



# VLAN Tagging

## System Availability: All systems

The MIPU / LIPU / LIPS and GIPU / GIPH and IP5000-series/IPT2000-series phones support 802.1Q Virtual Local Area Network (VLAN) technologies. For sites with LANs that have 1000's of IP devices, VLANs can be used to separate the network virtually rather than physically, to prevent the broadcast and other traffic from one virtual LAN (typically a data lan) from impairing the performance of equipment on another virtual LAN (for example a VoIP LAN) even though the devices are plugged into the same physical network. VLAN for the IPT phone and the phone's data port can each be programmed manually in the phone, or remotely through eManager. And within or without VLANs, 802.1P and Diffserv can be used to provide Quality of Service for voice by allowing voice packets to be prioritized over data packets. Note that when using 802.1Q or 802.1P it is important to ensure that all the network of the ethernet switches and routers are capable of supporting this.

Reasons why a company might want VLANs:

- Security – Separating systems that have sensitive data from the rest of the network decreases the chances that people will gain access to information they are not authorized to see.
- Projects/Special Applications – Managing a project or working with a specialized application can be simplified by using a VLAN that brings all the required nodes together.
- Performance/Bandwidth – Careful monitoring of network use enables the network administrator to create VLANs that reduce the number of router hops and increase the apparent bandwidth for network users.
- Access Lists – Provides the network administrator with a way to control who sees the different types of network traffic. An access list is a table the network administrator creates that lists which addresses have access to that network.
- Broadcasts/Traffic flow – Since a principle element of a VLAN is the fact that it does not pass broadcast traffic to nodes that are not part of the VLAN, it automatically reduces broadcast traffic.

## Voice or Tone Signaling

### **System Availability:** All systems

Each [DN] button can be programmed for either Voice or Tone Signaling as the standard method of internal incoming call signaling. Tone Signaling rings the telephone when a call comes in and ensures better privacy. With Tone Signaling, the called telephone receives a one-second ring tone every three seconds. The pitch and sound of internal tone signaling is always the same. Incoming CO line ringing is uniquely different, with up to four optional ring tone sounds.

With Voice Signaling, station users will hear a tone burst followed by the caller's voice over their telephone speaker when called by another station user locally or over the private network. Voice Signaling allows handsfree talkback from the called telephone on internal and private network Tie line calls.

After calling a directory number that has Voice Signaling, the caller can switch to Tone Signaling by dialing 1. The signaling method can also be switched from Tone to Voice Signaling by dialing 2. Whether a call is initiated with Tone or Voice Signaling, it can always be switched back and forth by dialing 1 or 2.

**Note** A call to a Voice Signaling [DN] will not Call Forward No Answer unless the signaling is switched from Voice to Tone Signaling.

## Voice Mail Integration

### **System Availability:** All systems

The CIX670 and CIX1200 supports Dual-tone Multi-frequency (DTMF) integration, Simplified Message Desk Interface (SMDI) integration, and Toshiba Proprietary integration.

### **DTMF Integration**

DTMF integration uses DTMF strings to pass and interpret information between the Strata CIX and a voice mail system. DTMF integration can be used with any compatible voice mail system. It does not require optional hardware interface.

### **Simplified Message Desk Interface (SMDI)**

SMDI is an industry standard method of integrating a telephone system with voice mail or other peripheral systems. This interconnection is made via an RS-232 data connection. SMDI requires the BSIS interface in the Strata CIX. SMDI integration can be used with any compatible voice mail system.

## Toshiba Proprietary Integration

Toshiba proprietary integration provides the highest functionality between the Strata CIX and a Strategy voice processing system. Toshiba proprietary integration requires the BSIS interface for control signaling between Strategy and Strata CIX. Toshiba proprietary integration is required to use Strategy voice processing system's support the features of Call Record to Voice Mail and Voice Mail Soft Keys.

### Call Record to Voice Mail

While on an active call, a station user can record the conversation and store it in a Strategy ES voice mailbox by pressing **Record** on the digital telephone. To end the recording, they can press **Record** again. Station users can also stop and start recording by pressing **PS/RES**.

Users can replay recorded messages by calling the voice mailbox that has the stored recording and play it back as any other message. The "record to" mailbox can be any mailbox number and can be accessed automatically when **Record** is pressed or dialed after **Record** is pressed.

Recording to Voice Mail (VM) is available on two-party and multi-party conference calls.

### Voice Mail Soft Keys (Strategy ES / iES32 / iES16 and GVMU / LVMU / GVPH only)

Voice Mail Soft Keys provide LCD telephone users with an active set of Soft Keys that prompt the user with available commands to play Voice Mail messages and to manage their mail boxes.

The LCD shows the number of New and Saved messages in the user's mailbox.

The number of New/Saved messages displays on the LCD when the telephone is idle and has at least one new message.

Soft Keys requires the Toshiba Proprietary VM integration and connection to the Strata CIX LAN.

## Direct Transfer to Voice Mailbox

The transferring party can transfer a call directly to a person's voice mailbox without waiting for the call to forward from the called party's telephone. The voice mailbox does not need to be associated with an active telephone in the Strata CIX. Direct transfer to voice mail (VM) can be performed to a centralized VM system connected to a network node other than the user's node.

The transferring party presses **Direct Transfer to VM** and dials the mailbox number, and the call transfers immediately on receipt of the last digit. The transferred party hears the greeting associated with the specified mailbox and can then leave a message.

Direct Transfer to Voice Mailbox simplifies getting a call for a busy or absent employee to his/her mailbox. It eliminates the need for the caller to enter the desired mailbox number after being connected to the voice mail system. This feature is available using standard DTMF or SMDI VM integration and does not require Toshiba proprietary VM integration.

## Volume Control

**System Availability:** All systems

Digital Telephone users can independently adjust their handset hearing volume, speaker hearing volume including BGM, speaker incoming tone volume and beep tone volume.

This page is intentionally left blank.

# Appendix – Specifications

This appendix includes detailed information on the items listed below. The sections in this appendix apply to the Strata CIX1200, CIX670, CIX200 and CIX100, unless otherwise stated. Refer to [page 13](#) for CIX40 requirements.

- [Environmental Characteristics](#)
- [Power Considerations](#)
- [MAS Power Considerations](#)
- [Reserve Power](#)
- [Strata CIX Component Compatibility](#)
- [Public Network Requirements](#)
- [Station Loop Lengths](#)
- [Standard Telephone Ringer Specifications](#)
- [5000/3000/3200-series Telephone Option Circuit Cards](#)
- [Station Dimensions](#)
- [System Tones](#)
- [Strata Net IP and IPT Bandwidth Requirements](#)
- [Strata CIX Software License Requirements](#)
- [Capacities](#)

For further details, refer to the *Strata CIX I&M Manual*.

## Environmental Characteristics

The environmental requirements for the Strata CIX40, CIX100, CIX200, CIX670, and CIX1200 systems are shown in [Table 22](#).

**Table 22 Environmental Characteristics for the Strata CIX systems**

Environmental Specifications	
Operating temperature	32~104° F (0~40° C)
Operating humidity	20~80% relative humidity without condensation
Storage temperature	-4~140° F (-20~60° C)
BTU Rating	
ACTU (1) or HCTU/HEXxU BCTU/BEXU (1 installed) BDKU (5 installed) RCOU/RCOS (1 installed) Digital Telephones (40 installed)	CIX100: 105 BTUs (31 watt hours) per cabinet. CIX670 and CIX1200: 190 BTUs (56 watt hours) per cabinet.

# Power Considerations

## CIX40

**Table 23 CIX40 Electrical Characteristics**

<b>CIX40 Primary Power</b>	
Input AC (Power Supply Specification)	120~240VAC
AC frequency	50/60 Hz
Power	CIX40 - 100 watts maximum
AC input current	1.3A maximum (100 VAC)
<b>Power</b>	
Input DC	15V use the factory-shipped AC adapter
<b>Power Converter</b>	
DC voltage output specification	-24VDC (-26.3 ~ -28.3VDC) +5VDC (+4.5 ~ +5.5VDC)
<b>Standard Telephone Ring Circuit (GMAU2 and GSTU1)</b>	
Ring Voltage	180V p-p square wave
Ringing capability	1 REN, 1 circuit - one telephone per circuit

## CIX100

The power supply in each CIX100 Base and Expansion Cabinet furnishes power to all of the stations and some of the interface peripherals (see [Table 24](#)). The primary AC power for each cabinet is 120VAC.

**Table 24 CIX100 Electrical Characteristics**

<b>CIX100 Primary AC Power Voltage</b>	
Input AC	120VAC
AC Frequency	60 Hz, Single-phase (48Hz~62Hz)
Watts per cabinet (maximum)	100 watts (maximum)
<b>CIX100 Primary Power Current Consumption (Rating in Amperes)</b>	
	120VAC
1 cabinet	1.8 amps
2 cabinets	3.6 amps
<b>Power Supply Unit (APSU112A)</b>	
DC voltage output specification	-24VDC (-26.3~-27.8VDC, 3.2 DC amps) +5VDC (+4.5~5.5VDC, 2.0 DC amps) -5VDC (-4.5~-5.5VDC, 0.2 DC amps) +3.3VDC (+3.0~3.6VDC, 0.5 DC amps)

## CIX200

**Table 25 CIX200 Electrical Characteristics**

<b>CIX200 Primary AC Power Voltage</b>	
Input AC	120VAC, 4.0 amps max.
AC Frequency	Single-phase (45Hz~65Hz)
Watts per cabinet (maximum)	480 watts (maximum)

## CIX670 and CIX1200

The power supply in each CIX670 and CIX1200 Base and Expansion Cabinet furnishes power to all of the stations and some of the interface peripherals (see [Table 26](#)). The primary AC power can be 120VAC, 208VAC or 240VAC. Systems containing six or seven cabinets require 208VAC or 240VAC. See [page 13](#) for CIX40 requirements.

**Table 26 CIX670 and CIX1200 Electrical Characteristics**

CIX670 and CIX1200 Primary AC Power Voltage			
Input AC	115±10VAC or 208±20VAC or 240±20VAC		
AC Frequency	50/60 Hz, Single-phase (48~62Hz)		
Watts per cabinet (continuous)	180		
Watts for five cabinet system	900		
CIX670 and CIX1200 Primary Power Current Consumption (Rating in Amperes)			
Number of Cabinets:	120VAC	208VAC	240VAC
1	3.2 amps	2.2 amps	2.0 amps
2	6.4 amps	4.4 amps	4.0 amps
3	9.6 amps	6.6 amps	6.0 amps
4	12.8 amps	8.8 amps	8.0 amps
5	16.0 amps	11.0 amps	10.0 amps
6	N/A	13.2 amps	12.0 amps
7	N/A	15.4 amps	14.0 amps
CIX1200 only Primary Power Current Consumption (Rating in Amperes)			
Number of Cabinets:	120VAC	208VAC	240VAC
8	3.2 amps	2.2 amps	2.0 amps
9	6.4 amps	4.4 amps	4.0 amps
10	9.6 amps	6.6 amps	6.0 amps
11	12.8 amps	8.8 amps	8.0 amps
12	16.0 amps	11.0 amps	10.0 amps
Power Supply Unit (BPSU672)			
DC voltage output specification	-24VDC (-26.3~-27.8VDC, 6.0 DC amps) +5VDC (+4.5~5.5VDC, 4.0 DC amps) -5VDC (-4.5~-5.5VDC, 0.8 DC amps)		

**Note** AC Power treatment for CIX1200 systems should be configured as two separate systems – one 7-cabinet stack and one 5-cabinet stack. This will require two 20 amp, 240VAC, single phase power circuits.

## MAS Power Considerations

**Table 27 MAS Electrical Characteristics**

MAS Primary AC Power Voltage	
Input AC	120VAC, 5.67 amps max.
AC Frequency	Single-phase (50Hz~60Hz)
Watts per cabinet (maximum)	680 watts (maximum)

**Note** The MAS is supplied with a standard 15 Amp power cord with a standard three-prong 120VAC that plugs into an AC power outlet. The MAS requires a dedicated, properly grounded circuit. Customer-supplied commercially available UPS systems should be used for power failure backup.

# Reserve Power

Two or four customer-supplied 12VDC reserve batteries (80 ampere-hours max.) can be connected to either system to maintain normal operation during a power failure (see [Tables 28~32](#)). The batteries are kept in a highly-charged state by the power supply’s battery charger and must be connected when the system is operating normally. Fully charged batteries must be connected when normal AC power is available, batteries cannot be connected after/during an actual power failure.

The Strata CIX200 does not have a battery; make sure you use Uninterruptible Power Supply (UPS). The battery charger is standard on the CIX670 and CIX1200 power supply. An optional ABCS battery charger must be used in the CIX100 power supply.

## CIX40 Reserve Power

Refer to “Reserve Power” on page 11.

**Table 28 CIX100 Reserve Power Characteristics**

Battery Charger Characteristics	Maximum Battery Charger Drain (-24VDC)	
Charger: current limiting	Base Cabinet	3.15 amps
Nominal float voltage: 2.275 volts/cell	Base + Expansion Cabinets	6.30 amps
Charge current: 280mA amps maximum		
Battery discharge cut-off voltage: 20.5 ±0.5VDC		

**Table 29 CIX100 Typical Reserve Power Duration Estimates<sup>1</sup>**

Number of Cabinets	1	2
Estimated operation time: two-battery configuration	25 hr.	12.5 hr.
Estimated operation time: four-battery configuration	50 hr.	25 hr.
DC Current Drain (-24VDC)	3.15 amps.	6.30 amps.

1. Assumes 80 ampere-hours with 12VDC batteries.

**Table 30 CIX670 Reserve Power Characteristics**

Battery Charger Characteristics	Maximum Battery Charger Drain (-24VDC)			
Charger: current limiting	1 cabinet	6.0 amps	5 cabinets	30.0 amps
Nominal float voltage: 2.275 volts/cell	2 cabinets	12.0 amps	6 cabinets	36.0 amps
Charge current: 0.7 amps maximum	3 cabinets	18.0 amps	7 cabinets	42.0 amps
Battery discharge cut-off voltage: 20.5 ±0.5VDC	4 cabinets	24.0 amps		

**Table 31 CIX1200 Reserve Power Characteristics**

Battery Charger Characteristics	Maximum Battery Charger Drain (-24VDC)			
Charger: current limiting	1 cabinet	6.0 amps	8 cabinets	6.0 amps
Nominal float voltage: 2.275 volts/cell	2 cabinets	12.0 amps	9 cabinets	12.0 amps
Charge current: 0.7 amps maximum	3 cabinets	18.0 amps	10 cabinets	18.0 amps
Battery discharge cut-off voltage: 20.5 ±0.5VDC	4 cabinets	24.0 amps	11 cabinets	24.0 amps
	5 cabinets	30.0 amps	12 cabinets	30.0 amps
	6 cabinets	36.0 amps		
	7 cabinets	42.0 amps		

**Note** Reserve power treatment for CIX1200 should be configured as two separate systems – one 7-cabinet stack and one 5-cabinet stack.



**Table 32 CIX670 and CIX1200 Typical Reserve Power Duration Estimates<sup>1</sup>**

<b>Number of Cabinets</b>	<b>1</b>	<b>2</b>	<b>3</b>	<b>4</b>	<b>5</b>	<b>6</b>	<b>7</b>
Estimated operation time Two-battery configuration	12.0 hr.	6.0 hr.	4.0 hr.	3.0 hr.	2.5 hr.	2.0 hr.	1.8 hr.
Estimated operation time Four-battery configuration	24.0 hr.	12.0 hr.	8.0 hr.	6.0 hr.	5.0 hr.	4.0 hr.	3.5 hr.
DC Current Drain (-24VDC)	4.6 amps.	8.7 amps.	12.8 amps.	16.9 amps.	21.0 amps.	25.1 amps.	29.2 amps.

1. Assumes 80 ampere-hours with 12VDC batteries.

**Table 33 CIX1200 Typical Reserve Power Duration Estimates<sup>1,2</sup>**

<b>Number of Cabinets</b>	<b>8</b>	<b>9</b>	<b>10</b>	<b>11</b>	<b>12</b>
Estimated operation time Two-battery configuration	12.0 hr.	6.0 hr.	4.0 hr.	3.0 hr.	2.5 hr.
Estimated operation time Four-battery configuration	24.0 hr.	12.0 hr.	8.0 hr.	6.0 hr.	5.0 hr.
DC Current Drain (-24VDC)	4.6 amps.	8.7 amps.	12.8 amps.	16.9 amps.	21.0 amps.

1. Assumes 80 ampere-hours with 12VDC batteries.

2. Reserve power treatment for CIX1200 should be configured as two separate systems – one 7-cabinet stack and one 5-cabinet stack.

## Strata CIX Component Compatibility

Because the Strata CIX supports all types of Toshiba IP and digital telephones, it provides the configuration flexibility to build the communications system you need, in addition to the investment protection from re-using devices from other Strata systems. That's why the Strata CIX is much more than just an IP system. It's a unified communications environment that supports many types of client devices.

Using the Strata CIX, your telephone can have peer-to-peer IP communication, Strata Media Application Server compatibility, and even use the same revolutionary FeatureFlex customization capabilities.

**Table 34 Component Compatibility**

<b>System Software and Features</b>	<b>CIX40</b>	<b>CIX100</b>	<b>CIX200</b>	<b>CIX670</b>	<b>CIX1200</b>
Strata CIX Software and features	X	X	X	X	X
FeatureFlex Adaptability features	X	X	X	X	X
<b>ACD / MIS</b>	<b>CIX40</b>	<b>CIX100</b>	<b>CIX200</b>	<b>CIX670</b>	<b>CIX1200</b>
Strata ACD	X	X	X	X	X
Insight Call Center Reporting	X	X	X	X	X
TASKE Call Center Reporting	X	X	X	X	X
<b>Administration</b>	<b>CIX40</b>	<b>CIX100</b>	<b>CIX200</b>	<b>CIX670</b>	<b>CIX1200</b>
Network eManager [Browser-based Unified (CIX & SES) Admin]	X	X	X	X	X
My Phone Manager™	X	X	X	X	X
WinCIX (Off-line Programming)	NC	X	X	X	X
<b>Processor Cards</b>	<b>CIX40</b>	<b>CIX100</b>	<b>CIX200</b>	<b>CIX670</b>	<b>CIX1200</b>
BECU/BBCU with optional BBMS, BEXS, BSIS	NC	NC	NC	X	NC
B_CAU/B_CBU cards for DK424i	NC	NC	NC	NC	NC
RCTU cards for DK424	NC	NC	NC	NC	NC
ACTU and subassemblies	NC	X	NC	NC	NC
LCTU and subassemblies	NC	NC	X	NC	NC
HCTU1 <sup>1</sup>	NC	NC	NC	NC	X
HEXAU1	NC	NC	NC	NC	X
HEXBU1	NC	NC	NC	NC	X
BCTU2 <sup>2</sup> and BEXU2	NC	NC	NC	X	NC
GCTU2A	X	NC	NC	NC	NC
<b>DTMF Receiver Unit</b>	<b>CIX40</b>	<b>CIX100</b>	<b>CIX200</b>	<b>CIX670</b>	<b>CIX1200</b>
BRCS-4/8/12	NC	NC	NC	NC	NC
RRCS-4/8/12	NC	NC	NC	NC	NC
ARCS (16) - (Used for the ACTU1 on the CIX 100, built-in on the other ACTU)	NC	ACTU1	Built-in (16)	Built-in (16)	NC
BEXU (Adds 16 DTMF receivers to the BCTU)	NC	NC	NC	BCTU	NC
<b>Optional Interface Unit</b>	<b>CIX40</b>	<b>CIX100</b>	<b>CIX200</b>	<b>CIX670</b>	<b>CIX1200</b>
BIOU	NC	X	X	X	X
BSIS	NC	X	X	X	X
<b>Standard Telephone Interface</b>	<b>CIX40</b>	<b>CIX100</b>	<b>CIX200</b>	<b>CIX670</b>	<b>CIX1200</b>
BSTU, RSTU3, RDSU/RSTS	NC	X	X	X	X
BSTCIU (Requires R4.1 software)	NC	X (R4.1)	X (R4.1)	X (R4.1)	X
BSLU / BSLU (Requires R3.1 or later software)	NC	X (R3.1)	X (R3.1)	X (R3.1)	X
ASTU (R1.3 and higher)	NC	X	NC	NC	NC
LSLU	NC	NC	X	NC	NC
GSTU	X	NC	NC	NC	NC
<b>Digital Telephone Interface</b>	<b>CIX40</b>	<b>CIX100</b>	<b>CIX200</b>	<b>CIX670</b>	<b>CIX1200</b>
ADKU	NC	X	NC	NC	NC

**Table 34 Component Compatibility** (continued)

BDKU	NC	X	X	X	X
BWDKU1A	NC	X	X	X	X
BDKS	NC	X	X	X	X
PDKU2 (DKT2000-series phones only)	NC	X	X	X	X
RDSU, RSTS (DKT2000-series only)	NC	X	X	X	X
GCDU	X	NC	NC	NC	NC
<b>IP Telephone Interface</b>	<b>CIX40</b>	<b>CIX100</b>	<b>CIX200</b>	<b>CIX670</b>	<b>CIX1200</b>
BIPU-M2A, BIPU-M1A <sup>3</sup>	NC	X	X	X	X
MIPU / LIPU / LIPS	MIPU only	X	X	X	X
<b>CO Line Interface</b>	<b>CIX40</b>	<b>CIX100</b>	<b>CIX200</b>	<b>CIX670</b>	<b>CIX1200</b>
BVPU	NC	X	X	X	X
RCIU/RCIS	NC	X	X	X	X
RCMU/RCMS	NC	X	X	X	X
RCOU/RCOS <sup>4</sup>	NC	X	X	X	X
BCOCIU / BCOCIS (Requires R4.1 software)	NC	X (R4.1)	X (R4.1)	X (R4.1)	X
RDDU	NC	X	X	X	X
RDTU2, 3	NC	X	X	X	X
REMU	NC	X	X	X	X
RGLU2, RGLU3	NC	X	X	X	X
GCDU	X	NC	NC	NC	NC
GCOCIU	X	NC	NC	NC	NC
<b>ISDN Interface</b>	<b>CIX40</b>	<b>CIX100</b>	<b>CIX200</b>	<b>CIX670</b>	<b>CIX1200</b>
BPTU1, RPTU2, RPTU	NC	X	X	X <sup>5</sup>	X
<b>Remote Exp. Cab.Interface</b>	<b>CIX40</b>	<b>CIX100</b>	<b>CIX200</b>	<b>CIX670</b>	<b>CIX1200</b>
RRCU	NC	NC	NC	X	X
<b>Strata Net over IP Interface</b>	<b>CIX40</b>	<b>CIX100</b>	<b>CIX200</b>	<b>CIX670</b>	<b>CIX1200</b>
BIPU-Q1A <sup>3</sup>	NC	X	X	X	X
MIPU / LIPU <sup>3</sup> / LIPS	MIPU only	X	X	X	X
GIPU / GIPH	X	NC	NC	NC	NC
<b>Stations and Terminal Equipment</b>	<b>CIX40</b>	<b>CIX100</b>	<b>CIX200</b>	<b>CIX670</b>	<b>CIX1200</b>
Strata CIX PC Attendant Console, BATI	X	X <sup>6</sup>	X	X	X
BPCI (USB) - Data or Voice Record TAPI	X	X <sup>4</sup>	X	X	X
DP5000	X	X <sup>4</sup>	X	X	X
DKT1000 <sup>7</sup>	X	X	X	X	X
DKT2000	X	X <sup>4</sup>	X	X	X
DKT3200/3000	X	X <sup>4</sup>	X	X	X
IPT1020-SD	X	X <sup>4</sup>	X	X	X
IPT2010-SD	X	X <sup>4</sup>	X	X	X
IPT2020-SD	X	X <sup>4</sup>	X	X	X
IPT2008-SDL	X	X <sup>4,6</sup>	X <sup>6</sup>	X <sup>8</sup>	X
IPT2010-SDC	X	X <sup>4</sup>	X	X	X
IP5000-series telephones	X	X <sup>4</sup>	X	X	X
SoftIPT softphone client for Laptop	X	X	X	X	X
SoftIPT softphone client for PDA	X	X	X	X	X
5000/3000/3200-series digital telephones	X	X <sup>9</sup>	X <sup>1</sup>	X <sup>1</sup>	X
DKT3207-SD (W) and DKT3207-SD 7-button digital telephone	X	NC	NC	NC	X
SIP (3 <sup>rd</sup> party) IP telephones (Requires MIPU <sup>10</sup> /LIPU/LIPS/GIPH)	X	X	X	X	X
SIP (3 <sup>rd</sup> party) IP telephones (Requires GIPU)	X	NC	NC	NC	X
2000-series digital telephones	X	X	X	X	X

**Table 34 Component Compatibility (continued)**

<b>Voice Mail</b>	<b>CIX40</b>	<b>CIX100</b>	<b>CIX200</b>	<b>CIX670</b>	<b>CIX1200</b>
Stratagy ES Standalone Models	X	X	X	X	X
Stratagy iES32 and iES16	NC	X	X	X	X
Stratagy IVP8	NC	X	X	X	X
LVMU1A	NC	X	X	X	X
GVPH1A	X	NC	NC	NC	NC
<b>Attendant Consoles</b>	<b>CIX40</b>	<b>CIX100</b>	<b>CIX200</b>	<b>CIX670</b>	<b>CIX1200</b>
Strata CIX IP Attendant Console (Requires MIPU/LIPU/LIPS/GIPU/GIPH)	X	X	X	X	X
Strata CIX Digital Attendant Console (Digital Telephone Port connection)	X	X	X	X	X
<b>Maximum Capacities</b>	<b>CIX40</b>	<b>CIX100</b>	<b>CIX200</b>	<b>CIX670</b>	<b>CIX1200</b>
KSU Cabinets (base plus expansion)	1	2	2	7	12
Base Cabinet PCB Slots	4	4	3	8	8
Expansion Cabinet PCB Slots	0	4	4	10	10
Total System PCB Slots	4	8	7	68	118
Trunk/Station/Voice mail Ports	57	112	192	672	1152
Trunk Lines	11	64	96	264	440
IP Telephones (IP5000-series/IPT2000-series) <sup>11</sup>	24	72	160	560	1000
Strata Net Channels	24	48	96	264	440
Digital Telephones (DP5000-series, DKT2000, 3000/3200)	16	72	112	560	952
Analog Standard Telephones	2	56	58	544	944
<b>Ethernet LAN</b>	<b>CIX40</b>	<b>CIX100</b>	<b>CIX200</b>	<b>CIX670</b>	<b>CIX1200</b>
AETS (Used for the ACTU1 on the CIX 100, built-in on the other ACTU processors)	Built-in	ACTU1	Built-in	Built-in	Built-in
<b>V.34 Admin Modem</b>	<b>CIX40</b>	<b>CIX100</b>	<b>CIX200</b>	<b>CIX670</b>	<b>CIX1200</b>
AMDS	NC	X	X	X	X
<b>Base Cabinet</b>	<b>CIX40</b>	<b>CIX100</b>	<b>CIX200</b>	<b>CIX670</b>	<b>CIX1200</b>
CHSUB672	NC	NC	NC	X	X
CHSUB112	NC	X	NC	NC	NC
CHSUB192A	NC	NC	X	NC	NC
CHSU40A	X	NC	NC	NC	NC
CHSU40A2	X	NC	NC	NC	NC
<b>Expansion Cabinet</b>	<b>CIX40</b>	<b>CIX100</b>	<b>CIX200</b>	<b>CIX670</b>	<b>CIX1200</b>
CHSUE672	NC	NC	NC	X	X
CHSUE112	NC	X	NC	NC	NC
CHSUE192A	NC	NC	X	NC	NC
Data Cable for CIX670 Expansion Cabinet	NC	NC	NC	X	X
Data Cable for CIX100 Expansion Cabinet	NC	X	NC	NC	NC
Data Cable for CIX200 Expansion Cabinet	NC	NC	X	NC	NC
<b>Power Supply Unit</b>	<b>CIX40</b>	<b>CIX100</b>	<b>CIX200</b>	<b>CIX670</b>	<b>CIX1200</b>
BPSU672 (120VAC/208VAC/240VAC power supply)	NC	NC	NC	X	X
APSU112 (120VAC)	NC	X	NC	NC	NC
<b>Conduit Connection Box</b>	<b>CIX40</b>	<b>CIX100</b>	<b>CIX200</b>	<b>CIX670</b>	<b>CIX1200</b>
RCCB2	NC	NC	NC	NC	NC
BCCB120 (120V box)	NC	NC	NC	X	X
BCCB240 (240V box)	NC	NC	NC	X	X
<b>Battery Distribution Box</b>	<b>CIX40</b>	<b>CIX100</b>	<b>CIX200</b>	<b>CIX670</b>	<b>CIX1200</b>
BBDB1 (new Battery Dist. Box, 7 BBTC2A-2.0M)	NC	NC	X	X	X

**Table 34 Component Compatibility** (continued)

<b>Power Strip</b>	<b>CIX40</b>	<b>CIX100</b>	<b>CIX200</b>	<b>CIX670</b>	<b>CIX1200</b>
RPSB2 (120VAC power strip)	NC	NC	NC	X	X
BPSB240 (240VAC power strip)	NC	NC	NC	X	X
<b>Battery Cable</b>	<b>CIX40</b>	<b>CIX100</b>	<b>CIX200</b>	<b>CIX670</b>	<b>CIX1200</b>
PBTC-3M	NC	NC	NC	X	X
BBTC1A-2.0M	NC	NC	NC	X	X
ABTC-3M	NC	X	NC	NC	NC
<b>Battery Charger</b>	<b>CIX40</b>	<b>CIX100</b>	<b>CIX200</b>	<b>CIX670</b>	<b>CIX1200</b>
ABCS1	NC	X	NC	Built-in	Built-in
HPFB-6 <sup>12</sup>	X	NC	NC	NC	NC

X= Compatible

NC = Not Compatible

1. When the HCTU processor is installed in the base cabinet (CHSUB672A or CRSUB672A), the system is a Strata CIX1200.
2. When the BCTU processor is installed in the base cabinet (CHSUB672A or CRSUB672A), the system is a Strata CIX670.
3. If a BIPU-M or BIPU-Q is installed RCOU1A, RCOS1A RDDU1A, RGLU1A, RGLU2A, and two-wire REMU1 cards should not be installed to avoid excessive Echo Return Loss (ERL).
4. The RCOS1A cannot be installed on the RCOU3A. The RCOS3 can be installed on the RCOU1A.
5. BPTU1, RPTU2, BIPU-Q1A, LIPU, or MIPU is required for Strata Net Networking.
6. Compatible with CIX40
7. DKT1000-series telephones do not support continuous DTMF tones.
8. Requires an MIPU / LIPU/LIPS card or MIPU / GIPU / GIPH on CIX40.
9. DP5022-SDM requires LIC-1-DP5022SDM license to operate on the CIX100/200/670/1200 systems.
10. Release 5.1 hardware is required to support the MIPU, GIPU and GCOCIH1A on the CIX40.
11. Refer to ["Telephones and Peripherals" on page 45](#) for numbers of IP5000-series phones supported in the system.
12. Provides battery with built-in charger.

# Public Network Requirements

The Circuit Card requirements for connecting to the public network are shown in [Table 35](#).

**Table 35 Circuit Card Network Requirements**

Circuit Card Interface	Facility Interface Code	Network Jack	Ringer Equivalence	Universal Service Order Code
BSTU <sup>1</sup> /RSTU3/RDSU <sup>2</sup> (Off-premises Station)	OL13B (RSTU3, -24V) OL13C (RSTU3, RDSU with R48S-48V)	RJ21X	N/A	9.0F
BSLU/BSLS <sup>3</sup> CIX40 Standard Telephone Interfaces	OL13B (-24V)	RJ21X	N/A	9.0F
BSTCIU (Analog Station <sup>4</sup> with Caller ID)	OL13B (-24V) OL13C (with R48S-48V)	RJ21X / RJ11C	N/A	9.0F
RCOU/RCOS <sup>5</sup> (loop start line)	02LS2	RJ14C/RJ21X (all others)	0.3B	N/A
RCIU2/RCIS (Caller ID)	N/A	RJ21X/RJ14C	0.3B	N/A
BCOCIU/BCOCIS CIX40 CO Line Interfaces	02LS2	RJ21X / RJ11C / RJ14C	0.3B	N/A
RDDU	02RV2-T (Dealer-supplied CSU)	RJ14C/RJ21X	0.0B	AS.2
REMU type 1 or type 2	TL11M, 2-wire TL31M, 4-wire TL12M, type 2, 2-wire TL32M, type 2, 4-wire	RJ2EX RJ2GX RJ2FX RJ2HX	Not Available (N/A)	9.0F
RGLU3 (ground or loop start line) <sup>2</sup>	02GS2 (ground) 02LS2 (loop)	RJ14C/RJ11CX	0.3B	N/A
RDTU (DS-1/T1) <sup>6</sup>	(See last bullet note on Note 2 below.)	RJ48C/RJ48X/ RJ48M	N/A	6.0P
BPTU, RPTU (PRI) <sup>7, 8</sup>	04DU9-1SN (Dealer-supplied CSU)	RJ48C/RJ48M	N/A	6.0P
BPTU, RPTU (Strata Net)	04DU9-1SN (Dealer-supplied CSU)	RJ48C/RJ48M		
RMCU/RCMS (CAMA)	02RV2-O	RJ11C/RJ21-X		

- BSTU parameters: Loop current 25mA to 35mA.  
Maximum loop resistance allowed:  
600ohm each without R48S1A - Class B (FCC Part 68)  
1200ohm each with R48S1A - Class C (FCC Part 68)  
Impedance: 600ohm
- Only RDSU ckts. 1-4 provide Off-premises Station (OPS) ability. RDSU must use OL13A or OL13B if providing -24 volt loop voltage. If equipped with the -48 volt loop option circuit card (R48S), OL13A, OL13B, or OL13C may be used for OPS connection.
- Supports one ringer per circuit. Does not support Message Waiting Lamp or OPS.
- BSTCIU parameters: Loop current 25mA to 35mA.  
Maximum loop resistance allowed:  
600ohm each without R48S1A - Class B (FCC Part 68)  
1200ohm each with R48S1A - Class C (FCC Part 68)  
Impedance: 600ohm  
Ring cadence: On 2 sec., Off 4 sec. (Use for Caller ID) or On 1 sec., Off 3 sec.
- Loop current requirements for Strata loop and ground start lines: 20 milliamperes (mA) min./120 mA max.

6. When ordering DS-1/T1 circuits, six items must be specified:
  - The number of channels per T1 circuit, fractional increments are normally 8, 12, or 16 channels, full service is 24 channels. Unused channels must be bit-stuffed.
  - CO line types assigned to each channel: Loop Start, Ground Start, Tie (Wink or Immediate Start), DID (Wink or Immediate).
  - Frame Format Type: Super Frame (SF) or Extended Super Frame (ESF). The T1 provider normally specifies the Frame Format to be used, either is adequate for CO digital voice lines. ESF provides a higher level of performance monitoring, but requires trained personnel and the ESF CSU normally costs more than an SF only CSU.
  - Line Code Type: Alternate Mark Inversion (AMI) or Bipolar 8 Zero Substitution (B8ZS). The T1 provider normally specified the Line Code to be used, either is adequate for T1 CO digital voice lines.
  - The customer may have to provide the Channel Service Unit (CSU) to interface the CIX T1 circuit to the Telco T1 circuit. (CSUs are a Telco requirement.)
  - RDTU Network Channel Interface Codes: 04DU9-BN, 04DU9-DNZZ, 04DU9-1SN, 04DU9-1KN, 04DU9-1ZN.
7. For information on how to order ISDN PRI circuits, you should refer to the Toshiba ISDN Training CBT. ISDN circuits may require a customer-provided CSU for PRI and/or Terminal Adapter or Network Terminal units for BRI. In U.S. CSU/TAs must be UL-listed in the U.S. In Canada, they must be CSA certified.
8. RPTU2 is required for Strata Net private networking.

# Station Loop Lengths

In a single site installation, the Base and optional Expansion cabinets must be placed within the allowed maximum distance of each other as designated by [Table 36](#).

**Table 36 Station Loop Lengths<sup>1</sup>**

Mode	Maximum line length (24 AWG)		
	1 Pair <sup>2</sup>	2 Pair (Not Available for CIX40 or BDKS)	1 Pair plus external power <sup>3</sup>
DP5000, DKT3000/3200 or DKT2000-series	1000 ft. (303m)	1000 ft. (303m)	1000 ft. (303m)
DP with DOCA DKT with BVSU or DVSU			
DP with DOCA-1A DKT with BHEU or HHEU			
DKT with BPCI			
DKT with BPCI + BHEU <sup>4</sup>			
DP with DOCA DKT with BVSU + BHEU <sup>4</sup> or DVSU + HHEU <sup>4</sup>	675 ft. (204m)		
DP with KM5020 or LM5110 DKT with DADM3020 or DADM2020 (1 ADM) <sup>2, 5</sup>	500 ft. (151m)		
DKT with DADM3020 or DADM2020 (2 ADMs) <sup>2, 5</sup>			
DDM5060 or DDSS3060, DDSS3060 or DDSS2060	1000 ft. (303m)	1000 ft. (303m)	1000 ft. (303m)
BATI, RATI		n/a	n/a
DDCB3		1000 ft. (303m)	1000 ft. (303m)
Standard telephones, voice mail, AA, etc.	Approx. 3000 ft. (909 m) with 150 ohm device. <sup>6</sup>	n/a	n/a
	Approx. 9000 ft. (2727 m) with 150 ohm device. <sup>6</sup>		
	Approx. 21000 ft. (6363 m) with 150 ohm device. <sup>6</sup>		
IPT2010-SD IPT2020-SD IPT2008-SD IPT1020-SD IPT2010-SDC	The IP telephone interface is 10Base-T/100Base-TX and requires CAT5/5e/6 twisted pair cabling. The maximum distance between the IP telephone jack and the ethernet device it connects to is 100 meters (328 ft.). This includes the 3 meter (9.84 ft.) straight-through CAT5 cable (black) supplied with the IP telephone. Ethernet devices include MIPU / LIPU / BIPU-M2A, BIPU-M1A servers, routers, etc.		
IP5022-SD, IP5122-SD, IP5132-SD, IP5131-SDL, and IP5122-SDC	10 Base-T / 100 Base-TX / 1000 Base-T		

1. When the system is powered by backup battery, range may be less as the backup battery is discharged.
2. One-pair wiring must be used with BWDKU and BDKS and CIX40 digital circuits (see [Figure 2](#)). The BWDKU and BDKS and CIX40 digital circuits do not support two pair wiring.
3. Two-pair wiring or optional telephone power supply is required to achieve maximum range in all cases.
4. DP5000-series does not require BHEU for headset and does not support BPCI.
5. BDKS and BWDKU do not provide the power wire pair; an external power supply is required to achieve maximum range (see "Digital Telephone DSS and DDCB External Power Connection" in Chapter 8 – MDF circuit card Wiring of the *Strata CIX I&M Manual*).
6. See manufacturer's product specifications for exact resistance of device.



# Standard Telephone Ringer Specifications

Specifications for standard telephone ringers appear in [Table 37](#).

**Table 37 Standard Telephone Ringer Specifications**

Interface Card	Ring Voltage	Ring Capacity	MW Voltage	Modem Data Rate	Ring Cadence	
RSTU3 or RDSU	75 Vrms@Ren1, 60 Vrms Ren 3, 20Hz	RSTU3: 3.0 ringers per circuit	RSTU3 and BSTU: - 120VDC-- 85VDC 0.9 sec. high/ 9.1 sec. low 1 telephone per circuit (max.)	14,400 bps maximum	Ring Cadence 1: (RSTU, RDSU, BSTU, BSLU, BSLS) External Ring: 20Hz, 1 sec. ON - 3 sec. Off Internal Ring: 20Hz, 0.4 sec. On - 0.2 sec. Off - 0.4 sec. On - 3 sec. Off Recall: 20Hz, 1 sec. On - 1 sec. Off	
BSTU		3 ringers per circuit				
BSLU/BSLS ASTU LSLU CIX40 mother board GSTU		1 ringer per circuit	None			Ring Cadence 2: (RSTU, RDSU, BSTU) External Ring: 20Hz, 0.4 sec. On - 0.2 sec. Off - 0.4 sec. On - 3 sec. Off11 Internal Ring: 20Hz, 1 sec. On - 3 sec. Off Recall: 20Hz, 1 sec. On - 3 sec. Off
BSTCIU		3 ringers per circuit	110 V +/- 10 1 Hz			Ring: 20Hz, 2 sec. ON - 4 sec. Off or 1 sec. ON - 3 sec. Off

## Standard Telephone Interface Options

The table below summarizes the standard telephone interface cards and their capacities and capabilities.

**Table 38 Standard Telephone Interface Options**

Interface Card	CIX Software Release Requirement	Interface Circuits per Card	Message Waiting Lamp Control	Message Waiting Off-Hook Audible Alert (stutter dial tone)	Off-Premise Station support (R48S card)	Standard telephone Caller ID and MW display.	Voice Mail Port, FAX machine, Modem, Standard 2500 telephone
BSTU1A	All Releases	8	Yes	Yes	Yes	No	Yes
BSTCIU1A	R4.1 and above	8	Yes	Yes	Yes	Yes	Yes
BSLU1A/ BSLS1A	R3.1 and above	8/8 total 16	No	Yes	No	No	Yes
ASTU, LSLU	CIX100 CIX200	2	No	Yes	No	No	Yes
Motherboard and GSTU	CIX40	1	No	Yes	No	No	Yes

Note: All standard telephone interface cards, including ASTU and LSLU, support off-hook selection of an outside line in CIX R4.1 and later.

# 5000/3000/3200-series Telephone Option Circuit Cards

DKT3000/3200-series telephones can be upgraded with option circuit cards to add a number of features. Each of these upgrades shares a circuit with the telephone that it is connected to and is not considered a station. See [Table 39](#) for more information.

**Table 39 3000/3200 Telephone Subassembly Upgrades**

Subassembly	No. per Phone	Function
BVSU <sup>1</sup> (DKT) DOCA (DP)	1	<b>Speaker Off-hook Call Announce (OCA):</b> Provides interface for digital telephone to receive Speaker OCA. Not required for Handset/Headset OCA. (Built into IP telephones).
BHEU or HHEU <sup>2</sup>	1	<b>Headset and external ringer telephone interface:</b> Can be installed with BVSU, BPCI or DADM. (Built into IP telephones).
BPCI <sup>1,3</sup>	1	Desktop PC Interface for CTI applications.

1. Telephones with the BPCI cannot have Speaker OCA (BVSU) or Add-on modules. Also, DKT3001, DKT3201 telephones cannot have CTI (BPCI), Speaker OCA (BVSU) or Add-on modules.
2. DP5000-series telephones have a built-in headset interface and do not require BHEU or HHEU.
3. DP5000-series do not support the BPCI interface.

# Station Dimensions

Dimensions for the 3000-series, IPT telephones and related equipment are listed in [Table 40](#).

**Table 40 Station Dimensions**

Device	Height		Width		Depth	
	Inches	mm	Inches	mm	Inches	mm
IP5022-SD, IP5122-SD, IP5122-SDC, IP5132-SD, IP5131-SDL [15-degree tilt]	5.1	129	10.16	258	6.10	155
IP Direct Station Selection (DSS) Console - IDM5060 [15-degree tilt]	4.0	102	10.16	258	6.10	155
DP5018-S, DP5022-SDM, DP5022-SD, DP5122-SD, DP5032-SD, DP5132-SD, DP5130-SDL, DP5130-FSDL [15-degree tilt]	5.1	129	10.16	258	6.10	155
Single Line Telephone (DP5008) [15-degree tilt]	3.86	98	5.9	150		
Add-on Module (KM5020, LM5110) [15-degree tilt]	4.0	102	3.54	90		
Direct Station Selection (DSS) Console (DDM5060) [15-degree tilt]			10.16	258		
10-button IP Telephone with LCD (IPT2010-SD) 20-button IP Telephone with LCD (IPT2020-SD) 8-button IP Telephone with large LCD (IPT2008-SDL)	4.5	115	7.8	198	9.6	245
Add-on Module (IADM2020)	3.8	96.5	2.8	70		
Direct Station Selection (DSS) Console (IDSS2060)	3.8	96.5	7.8	198		
20-button IP Telephone with LCD (IPT1020-SD)	4.0	101.5	8.1	205	9.3 in.	235
Digital Single Line Telephone (DKT3001)	4.0	101.5	5.9	150		
Add-on Module (DADM3020, DADM3120)	3.5	88	2.8	70		
Direct Station Selection (DSS) Console (DDSS3060)	3.5	88	8.1	205		
Handset with Handset Cradle (BATHC)	2.9	73	2.8	71	9.6	244
10-button DKT with Handsfree Answerback (DKT2010-S)	4.1	104	7.7	195	9.1	230
10-button DKT with LCD (DKT2010-SD)						
20-button DKT (DKT2020-S)						
20-button DKT with LCD (DKT2020-SD)						
20-button DKT with LCD (DKT2020-FDSP)						
Digital Single Line Telephone (DKT2001)	4.2	107	5.5	140	9.1	230
Add-on Module (DADM2020)	3.3	85	2.8	70	9.1	230
Direct Station Selection (DSSS2060) Console	3.3	85	7.8	199	9.1	230
External Speaker Amplifier (BESCB)	10.2	260	10.2	260	4.9	125
Door Phone/Lock Control Unit (DDCB)	4.7	120	6.5	165	1.5	38
Door Phone (MDFB)	5.5	140	3.1	80	1.3	32
Attendant Console Interface (BATI)	1.7	42.4	5.0	126	7.3	185
<b>DKT2404-DECT Digital Cordless Telephone</b>	<b>Height</b>		<b>Width</b>		<b>Depth</b>	
	<b>Inches</b>	<b>mm</b>	<b>Inches</b>	<b>mm</b>	<b>Inches</b>	<b>mm</b>
Base	5	127	8.5	216	2.25	57.15
Handset	6.5	165	2.25	57.15	1.0	25.4
<b>DKT2204-CT Digital Cordless Telephone</b>	<b>Height</b>		<b>Width</b>		<b>Depth</b>	
	<b>Inches</b>	<b>mm</b>	<b>Inches</b>	<b>mm</b>	<b>Inches</b>	<b>mm</b>
Base	2.0	50.8	2.75	69.85	2.813	71.45
Handset (with antenna)	8.66	219.96	2.2	55.89	1.66	42.16
<b>DKT2304-CT Digital Cordless Telephone</b>	<b>Height</b>		<b>Width</b>		<b>Depth</b>	
	<b>Inches</b>	<b>mm</b>	<b>Inches</b>	<b>mm</b>	<b>Inches</b>	<b>mm</b>
Base	2.25	57.15	4.25	107.95	7.625	193.67
Handset (with antenna)	5.5	139.7	2.0	50.8	1.25	31.75

# System Tones

Tones which can be heard from speaker or handset are described in [Table 41](#).

**Table 41 Call Progress Tones**

Tone Name	Conditions	Ringing Cadence
Prime Dial Tone	Prompting to dial [DN] or access code or to press a feature button or to dial 9 + number.	350/440Hz continuously On.
Secondary Dial Tone (optional)	Prompting to dial [DN] or access code or to press a feature button, with someone on Consultation Hold.	
DND-Stuttered Dial Tone (optional)	Same as Prime Dial Tone with implication of DND activated. MW-Stutter dial tone has priority over this tone.	480/620Hz 0.125 sec. 4 bursts apart 0.125 sec., 350/440Hz 3 sec. On, repeat.
MW-Stuttered Dial Tone	Same as Prime Dial Tone with implication of MW received. This tone has a priority over DND-Stutter dial tone.	350/440Hz 0.1 sec. 5 bursts apart 0.1 sec., 3 sec. On, repeat.
Entry Tone	More digits are required such as account codes, some indexes, etc.	350/440Hz, 0.1 sec. 3 bursts apart 0.1 sec.
Ring Back Tone	Ringling the destination	440/480 Hz 1 sec. On, 3 sec. Off, repeat.
Success Tone (Confirmation Tone)	Operation was successfully accepted.	350/440 Hz, 3 bursts of 0.125 sec., apart 0.125 sec.
Reject Tone	Operation was rejected. After this tone is done, the original conversation is resumed.	1209 Hz 0.25 sec., 500 Hz 0.25 sec., 3 times.
Busy Tone	Destination is busy. Invoke desired feature or retry later.	480/620 Hz, 0.5 sec. On, 0.5 sec. Off, repeat.
Reorder Tone	Either the operation failed or the call is terminated. Hang up.	480/620 Hz, 0.25 sec. On, 0.25 sec. Off, repeat.
DND Tone	The destination is in the Do Not Disturb mode.	480/620 Hz, 0.125 sec. On, 0.125 sec. Off, repeat.
Splash Tone	Voice calling starts. Applicable to Voice Paging and Speaker OCA.	500 Hz, 1.0 sec. On.
Barge-in Warning Tone	Somebody is listening to (monitoring) the conversation.	440 Hz 1.0 sec. On.
External Call Waiting Tone for Standard Telephone	An external call is waiting. This tone is sent to the receive party only.	1209 Hz, 2 bursts of 0.16 sec. apart 0.16 sec., twice, 3 sec. apart.
Internal Call Waiting Tone for Standard Telephone	An internal call is waiting or somebody is listening to (monitoring) the conversation.	1209 Hz, 2 bursts of 0.5 sec. On, apart 3.0 sec.

Ring tones are described, along with their cadences in [Table 42](#). Due to the limitation in the tone generation algorithm, the listed tone duration is slightly different from the actual one.

**Table 42 Ring Tones**

Tone Name	Description	Ringing Cadence
Internal/External Ring 1	Incoming call from internal or external party to DP or IPT. (10 different ring tones are available with R1.3 or higher software.)	500 Hz 1 sec. On, 3 sec. Off, repeat
Internal/External Ring 2		1300 Hz 1 sec. On, 1 sec. Off, repeat
Internal/External Ring 11		500/640 Hz 1 sec. On, 3 sec. Off, repeat
Internal/External Ring 12		500/640 Hz 1 sec. On, 1 sec. Off, repeat
Internal/External Ring 13		860/1180 Hz 1 sec. On, 3 sec. Off, repeat
Internal/External Ring 14		860/1180 Hz 1 sec. On, 1 sec. Off, repeat
Internal/External Ring 15		1300/1780 Hz 1 sec. On, 3 sec. Off, repeat
Internal/External Ring 16		1300/1780 Hz 1 sec. On, 1 sec. Off, repeat
Internal/External Ring 17		860/1180 Hz 0.5 sec. On, 1300/1780 Hz 3 sec. Off, repeat
Internal/External Ring 18		860/1180 Hz 0.5 sec. On, 1300/1780 Hz 1 sec. Off, repeat
External/Internal Ring for Standard Telephones		Internal and External Ringing Cadence: For Release 1.3 and higher, two types of ringing cadences can be selected in system programming.
	Ringing Type 2: Same Ringing Cadence as DK. External Ring: 20Hz, 0.4 sec. On - 0.2 sec. Off - 0.4 sec. On - 3 sec. Off Internal Ring: 20Hz, 1 sec. On - 3 sec. Off Recall: 20Hz, 1 sec. On - 3 sec. Off	
Recall	A call is returned & needs to be answered.	2 kHz interrupted at 10 Hz, 1 sec. On, 1 sec. Off, repeat.
Recall for Standard Telephone	A call is returned & needs to be answered.	20 Hz, 1 sec. On, 1 sec. Off, repeat.
Ring Over Busy (Internal)	Call rings an idle [DN] or CO line button while phone is busy. Another internal call offered to an idle button while the station is busy.	2 kHz interrupted at 10 Hz, 1 sec. On, 3 sec. Off, twice or repeat (For Call Waiting, twice only).
Call Waiting (Internal)	Internal call is waiting for the busy button. A call is camped-on to a busy [DN] or CO line button.	
Ring Over Busy (External)	Call rings an idle [DN] or CO line button while phone is busy. Another incoming call is offered to an idle button while phone is busy.	2 kHz interrupted at 10 Hz, 2 bursts of 0.25 sec. apart 0.25 sec., twice apart 3 sec. or continuous (For Call Waiting, twice only). Standard telephones with Caller ID also receive an 80 ms burst of CAS tone at -14 to 32dBm
Call Waiting (External)	External call is waiting for busy station. A call is camped-on to a busy [DN] or CO line button.	
Volume Control - Ringing Speaker	Adjusts speaker volume for ringing state.	500/640 Hz continuous.

Other types of tones that do not fit in the previous categories are listed in [Table 43](#).

**Table 43 Administration/Programming Tones**

<b>Tone Name</b>	<b>Description</b>	<b>Ringling Cadence</b>
Confirmation Tone	During user programming or administration mode, indicates the acceptance of input.	2 kHz two bursts of 0.125 sec. apart 0.125 sec.
Denial Tone	During user programming or administration mode, indicates the denial of input.	2 kHz 0.75 sec. On.
Volume Control - Beep	To adjust the beep volume.	2 kHz interrupted 10 Hz, continuous.

# Strata Net IP and IPT Bandwidth Requirements

The amount of bandwidth required for communications over a particular IP network segment depends on the number of voice channels supported, the anticipated call setup traffic, and how much other data network traffic is present.

The quality of service (Excellent, Good, Fair, and Poor) provided by Strata Net IP channels and IP telephones depends heavily on the LAN parameters as shown in Table 44. This table shows the amount of bandwidth required for each Strata Net IP voice call (without data traffic) based on the interval and the CODEC.

**Table 44 Strata Net IP and IPT Quality of Service**

IP Network Quality Parameters		Speech			
		Excellent: No one perceives delay. <sup>1</sup>	Good: Very few people perceive delay. <sup>1</sup>	Fair: Some people may perceive delay. <sup>1</sup>	Poor: Many people may perceive delay. <sup>1</sup> IPT is usable even with a "Poor" rating if delay is acceptable.
Latency (Round trip delay) <sup>2</sup>		20ms or less	50ms or less	100ms or less	200ms or less
Jitter <sup>2</sup>		20ms or less (-10 ms ~ +10ms)	50ms or less (-25ms ~ +25ms)	50ms or less (-25ms ~ +25ms)	50ms or less (-25ms ~ +25ms)
Packet loss <sup>2</sup>		1×10 <sup>-3</sup> or less	1×10 <sup>-3</sup> or less	1×10 <sup>-3</sup> or less	1×10 <sup>-3</sup> or less
Packet error <sup>2</sup>		1×10 <sup>-4</sup> or less	1×10 <sup>-4</sup> or less	1×10 <sup>-4</sup> or less	1×10 <sup>-4</sup> or less
Speech quality dependency on CODEC parameters		Speech quality as the combination of the above network environment and the CODEC parameters.			
CODEC and packet interval in ms	Bandwidth per channel (Single direction, control channel included)				
G.711 at 20ms i Prg 250-07 Prg 152-01	88kbps <sup>3</sup>	Excellent	Good	Fair	Poor
G.711 at 40ms i Prg 250-07 Prg 152-01	76kbps <sup>3</sup>	Excellent	Good	Fair	Poor
G.729A at 40ms Prg 250-07 Prg 152-01	20kbps <sup>3</sup>	Good	Good	Fair	Poor
G.729A at 80ms Prg 250-07 Prg 152-01	14kbps <sup>3</sup>	Good	Fair	Poor	Poor

1. Ratings of Excellent, Good, Fair, Poor were based on the tester in a quiet room and the tester could not see the other call party.
2. When selecting router equipment, the Latency, Jitter, Packet loss and Packet error conditions above should be considered as well as the bandwidth. Bandwidth can be calculated with the CODEC and packet size. For better results, more bandwidth may be required, depending on the amount of overall data traffic. For more details on QoS refer to "A Handbook for Successful VoIP Deployment: Network Testing, QoS, and More" by John Q. Walker, NetIQ Corporation on [www.netiq.com](http://www.netiq.com).
3. Use this number to estimate the bandwidth needed for the CODEC and IP headers required to achieve an expected Quality of Service (Excellent, Good, etc.). When planning you should allow extra bandwidth, especially when mixing voice and data.

When sharing voice and data on the same network segment, the data will cause some jitter in voice communications, especially on slower segments. [Table 45](#) shows calculations of the amount of jitter assuming a worst case data packet size of 1500 bytes (Maximum Transmission Unit (MTU) = 1500) based on a segment’s bandwidth. This also requires that the routers connecting the segment through the WAN support Diffserv.

**Note** A router that doesn’t support Diffserv may stack multiple data packets together increasing the jitter perhaps indefinitely. And the voice quality will be indeterminate.

**Table 45 Strata Net IP Jitter on Mixed Voice and Data WAN**

No. of B-Channels of WAN	Bandwidth (kbps)	Time to transmit max. MTU (ms)	Expected Jitter (ms)	Class
2	128	93.75	100	Poor
4	256	46.88	50	Fair
6	384	23.44	30	Fair
8	512	15.63	20	Good
24	1536	1.00	1	Excellent

Class definition categories are shown in [Table 46](#).

**Table 46 Strata Net IP Class Definitions**

Class	Delay (ms)	Jitter (ms)
Excellent	< 20	< 10
Good	< 50	< 20
Fair	< 100	< 50
Poor	< 200	< 100

[Table 47](#) shows the amount of bandwidth required for setting up and tearing down calls independent of the amount of voice traffic.

**Table 47 Strata Net IP Bandwidth Required for Call Setup**

Traffic Rate (BHCA <sup>1</sup> )	Required Bandwidth
1000	6
2000	12
4000	23
6000	36

1. BHC = Busy Hour Call Attempts

So the amount of bandwidth that is required on a segment to support a specific number of calls is the sum of the number of channels multiplied by the bandwidth for the selected CODEC and interval, plus the bandwidth required for the selected number of busy hour call attempts. And the jitter is determined by the bandwidth of the WAN segment.

Example: If you want to support 4 calls using the G.711 CODEC with a 20 msec. interval, this requires 4 x 88 kbps = 352 kbps of bandwidth. In addition, to support 1000 busy hour call attempts, 6 kbps must be added for a total of 358 kbps. If only voice is going to be carried on the segment, then a 384 kbps segment (6 B-channels) is sufficient.

If voice and data are going to be mixed on the segment, then at least 25% (89.5 kbps) should be added, or more, based on the amount of data traffic desired. In this case, a total of 447 kbps will be required which would best be supported by a 512 kbps segment (8 B-channels). This would result in an expected jitter of 20 ms in the voice traffic.

When using the MEGACO+ protocol with IPT telephones, keep alive packets are exchanged between the IPU and the phones. This traffic amounts to 3 kbps per phone.



# Strata CIX Software License Requirements

Table 48 describes the content and use for each Strata CIX license.

**Table 48 Licenses for all Strata CIX Systems**

New License	Description	Comments
LIC-4 BASIC <sup>1</sup>	4-port CO Line/Station License for CIX Systems	One required for every four ports used for CO lines, DP or SLT stations, Attendant Consoles, voice mail ports, Strata Net and ACD announcement ports beyond the ports bundled with the system processor.
LIC-4 DTMF <sup>1</sup>	4-port DTMF Receiver License for CIX Systems	Required for activation of four DTMF receiver ports number 5 and above on system. Maximum is determined by the CTU card in use.
LIC100-STRATA N <sup>1</sup>	CIX100 Strata® Net Networking Application License.	One per CIX100 system (node) required to network multiple systems using Strata® Net networking.
LIC200-STRATA N <sup>1</sup>	CIX200 Strata® Net Networking Application License.	One per CIX200 system (node) required to network multiple systems using Strata® Net networking.
LIC670-STRATA N <sup>1,2</sup>	CIX670 Strata® Net Networking Application License.	One per CIX670 system (node) required to network multiple systems using Strata® Net networking.
LIC1200STRATA N <sup>1,2</sup>	CIX1200 Strata® Net Networking Application License.	One per CIX1200 system (node) required to network multiple systems using Strata® Net networking.
LIC-CIX-STRN-CH	Strata Net channel license LIC-CIX-STRN-CH is only available in R4.1 version MN023 and above.	This license allows you to license a specific number of Strata Net channels on Strata CIX systems. The same license part number, LIC-CIX-STRN-CH can be used on any R4.10 (MN023) and above Strata CIX system. This license makes Strata CIX networking more competitive for the CIX system applications that require 12 or less Strata Net channels. The Strata Net system licenses LIC100-STRATA N, LIC200-STRATA N, LIC670-STRATA N, and LIC1200STRATA N are still available for applications that require more than 12 Strata Net channels. The CIX40 uses the Strata Net channel license and does not require a Strata Net system license.
LIC-CIX-SIPT-CH	SIP Trunking License, only available with R5.1MS17 and above; MIPU01-06 firmware.	This license allows you to license a specific number of SIP Trunks on Strata CIX systems. The same license part number, LIC-CIX-SIPT-CH can be used on any R5.1MS17 and above Strata CIX system.
LIC-SER PORT <sup>1</sup>	Serial Port License required for BSIS Ports 2, 3 and 4 for CIX.	Required to activate serial port 2, 3 and 4 in Strata CIX systems (license for serial port one included with BSIS).
(Sheet 1 of 2)		

## Appendix – Specifications

### Strata CIX Software License Requirements

New License	Description	Comments <i>(continued)</i>
LIC-ACD <sup>1</sup>	CIX ACD Server License	Required to activate ACD support in a Strata CIX system. (This license is included with ACD turnkey packages and software packages.)
LIC-SOFTIPT	License for one SoftIPT user on Strata CIX.	One required for each SoftIPT application interfaced to the Strata CIX. One MIPU / LIPU or LIPS or BIPU-M port is required for each SoftIPT. Requires an IP endpoint license when connected to LIPU/S.
LIC-2 LVMU	LVMU two port Voice Mail license requires R4.2 MP026 or higher software.	R4.2MP026 software provides two LVMU Voice Mail port licenses by default. LIC-2 LVMU is required for 4, 6, or 8 VM ports. One Basic Port License is also required for each voice mail port.
LIC-2 GVPH	GVPH two port VM licenses requires R5.1 software or higher.	CIX40 R5.1 software provides four GVPH voice mail port licenses by default. LIC-2 GVPH is required for six or eight voice mail ports.
LIC-1 DP5022SDM	DP5022-SDM telephone migration license.	One license is required on CIX100, CIX100-S, CIX200, CIX670, and CIX1200 for each DP5022-SDM. LIC-DP5022-SDM is not required for DP5022-SDM or CIX40.
LIC-CIX-IP PORT	IP Endpoint License for Strata CIX.	IP Endpoint License required per IP telephone connected to MIPU or LIPU/S. If the CIX software version is R5.0 or later, the IP endpoint license is used when the IPT or SoftIPT is registered. If the CIX software version is R4.x or 3.x, the IP endpoint license will be used as soon as the DN for the IPT or SoftIPT has been created.
LIC-CIX-FF <sup>1</sup>	FeatureFlex license for CIX.	Strata CIX license to activate FeatureFlex. Requires one per CIX system to run FeatureFlex applications.
The following license is included in some of the license packages, they are not sold separately.		
LIC-ATT <sup>1</sup>	CIX Attendant Console License	Required to activate Attendant Console support in a Strata CIX system. This license is included in the Attendant Console Part Number.
(Sheet 2 of 2)		

1. This license is not required on the CIX40 for Feature or Port activation, but is required for all other CIX systems.
2. All licenses applied to Strata CIX670 processors can be transferred to the CIX1200 processor.

**Table 49 Type and Number of Licenses Required by Feature**

		IP Interface Card	Basic Port License <sup>1</sup>	Strata Net System License <sup>2</sup>	Strata Net Channel License <sup>3</sup>	SoftIPT License <sup>4</sup>	IP Port License <sup>5</sup>
<b>CIX R3.1 and above</b>	IP ACD (MAS) announcement ports	MIPU / LIPU/S GIPU/ GIPH	Each Port				
	IP Attendant Console	MIPU / LIPU/S GIPU/ GIPH	Each Port				
	IP Voice Mail (MAS)	MIPU / LIPU/S GIPU/ GIPH	Each Port				
	Strata Net IP System <sup>6</sup>	MIPU / LIPU/S	Each Channel	per system			
	Strata Net IP Channel <sup>3</sup>	MIPU / LIPU/S GIPU/ GIPH			Each Channel		
	IPT-2008-SDL	MIPU / LIPU/S GIPU/ GIPH					Each Active Station
	IPT-2010-SD/2020-SD/ 2010-SDC	MIPU / LIPU/S GIPU/ GIPH					Each Active Station
	IP5000-series telephones	MIPU / LIPU/ SGIPU/ GIPH					Each Active Station
	SIP Phone	MIPU / LIPU/ SGIPU/ GIPH					Each Active Station
	SoftIPT	MIPU / LIPU/ SGIPU/ GIPH				Each Active Station	Each Active Station
<b>CTX R2.2 features supported in R3.1</b>	IPT-1020	BIPU-M	Each Station				
	IPT-2010-SD/2020-SD	BIPU-M	Each Station				
	SoftIPT	BIPU-M	Each Station			Each Station	
	Strata Net IP	BIPU-Q	Each Trunk	per system			
	ACD announcement ports	N/A	Each Port				
	Attendant Console	N/A	Each Console				
	DKT/SLT Interface ports <sup>7</sup>	N/A	Each Port				
	Trunk Interface Port	N/A	Each Port				
	Voice Mail ports <sup>8</sup>	N/A	Each Port				

## Appendix – Specifications

### *Strata CIX Software License Requirements*

1. LIC-4 BASIC (Not required on CIX40, but is required on all other CIX systems).
2. LIC100 STRATA N; LIC200 STRATA N; or LIC670 STRATA N; Not required on CIX40
3. LIC-CIX-STRN-CH (not required when using LICxxx-STRATA N system license).
4. LIC-SOFTIPT
5. LIC-CIX-IP PORT
6. Not required when using LIC-CIX-STRN-CH for Strata Net
7. See [Table 48 on page 173](#) for LIC-1 DP5022SDM license information.
8. See [Table 48 on page 173](#) for LIC-2 LVMU and LIC-2 GVPH for LVMU/GVPH voice mail license information.

# Capacities

The following tables contain Strata CIX40, CIX100, CIX200, CIX670, and CIX1200 capacities for stations and peripherals, CO lines, station buttons and system features. Tables are divided based on the small Strata CIX systems (CIX40, CIX100 and CIX200) and large Strata CIX systems (CIX670 and CIX1200).

**Table 50 Cabinet and Slot Capacities for Strata CIX40, CIX100 and CIX200**

Cabinets/Slots/Ports	CIX40 GCTU2A	CIX100 ACTU	CIX200 LCTU
Cabinets	1	1 to 2	1 to 2
Universal slots	Dedicated slots	4 or 8	3 or 7
Maximum capacity of ports including Voice Mail ports (lines + stations)	57	112	192

**Table 51 Station/Peripherals System Capacities for Strata CIX40, CIX100 and CIX200**

Stations	CIX40	CIX100 Base & Expansion	CIX200 Base and Expansion
Digital Add-on modules per Base Cabinet <sup>1</sup>	16 System 1 or 2 per DP	30 DPs with 1 DADM 23 DPs with 2 DADMs	46 DPs with 1 DADM 36 DPs with 2 DADMs
Digital Add-on modules per Expansion Cabinet <sup>1</sup>	N/A <sup>2</sup>	31 DPs with 1 DADM 24 DPs with 2 DADMs	46 DPs with 1 DADM 36 DPs with 2 DADMs
CIX Attendant consoles	2	2	2
DP5000, DKT3200, 3000 and 2000-series DKTs <sup>1</sup>	16	72 (40 Base Cabinet) (40/Expan. Cab.)	112
IP5000-series/IPT2000-series telephones <sup>3</sup>	24	64 per cabinet 72 per system	160 per System 80 per cabinet
KM5020, LM5110 and IADM2020 on IPTs <sup>4</sup>	48 per system 2 IADM2020 per IPT	53 per cabinet 53 per system	58 per System 58 per cabinet
DKT2204-CT or DKT2304-CT Cordless Telephone <sup>1</sup>	16	72	112
Door locks <sup>5</sup>	3	4	5
Door phone control boxes (DDCB)	2	2	3
Door phones	6	6	9
DSS consoles (DSS)	3 per system 3 per station	3 per system 3 per station	5 per system 5 per station
Off-premise stations	2 <sup>6</sup>	56	58
BPCI used for TAPI only: per cabinet <sup>1</sup>	16 <sup>7</sup>	35	48 Base Cabinet 54 Expansion Cabinet
Total Stations (Digital/Analog)	18	72	160
Standard stations <sup>8</sup>	2	56	58
DTMF Receivers <sup>9</sup>	16	16	16
Calls existing at the same time	unlimited	unlimited	96

## Appendix – Specifications

### Capacities

1. Limit is based on cabinet Power Factor (PF).
2. N/A means Not Available.
3. Limited by system bus traffic.
4. Limited by the number of flexible buttons per system.
5. Each Door lock reduces the number of Door Phones by one Door Phone and vice versa.
6. OL13A and OL13B only.
7. CIX40 cannot use 2B channels on digital telephones.
8. Capacity includes standard telephones with or without Caller ID interface. Caller ID interface requires R4.1 or later software.
9. DTMF receivers are required for standard touch tone telephones, voice mail integration, Tie, DID and DISA lines.

**Table 52 Line Capacities and Universal Circuit Card Slots for Strata CIX40, CIX100 and CIX200**

Lines	CIX40	CIX100 Base & Expansion	CIX200 Base and Expansion
CO lines – loop start (analog - 8 lines/slot)	11 with built-in CLID	64	56
CO lines – ground start (analog - 4 lines/slot)	N/A <sup>1</sup>	32	28
DID lines (analog - 4 lines/slot)	N/A <sup>1</sup>	32	28
Tie lines (analog - 4 lines/slot)	N/A <sup>1</sup>	32	28
T1 lines (DS-1) <sup>2</sup>	N/A <sup>1</sup>	64	96
ISDN PRI B channel lines <sup>3</sup>	N/A <sup>1</sup>	48	96
Strata Net IP Channels <sup>4</sup>	24	48	96
SIP Trunking	24	48	96
Total lines (Analog, T1, and ISDN PRI B channels combined)	11	64	96
Channel Groups	1 (IP)	32	48
Number of groups w/ GCO Line buttons	8	32	50
Busy Tone Detectors	16	16	16

1. N/A means Not Available.
2. T1 lines can be loop start, ground start, Tie or DID (maximum 24 lines per unit, any type or combination).
3. PRI lines provide CO line services, including Strata Net Networking, Calling Party Number/Name, DID, Tie, POTS, FX and DIT.
4. IP Strata Net channels provides CIX networking functionality.

**Table 53 Digital and IP Telephone Station Buttons for Strata CIX40, CIX100 and CIX200**

Station Buttons per System	CIX40	CIX100 Base & Expansion	CIX200 Base and Expansion
Call Forward, Personal CF Buttons	24	72	160
Caller ID (CLID) button (DP or IPT only)	24	72	160
CO Line Buttons <sup>1</sup>	6	64	56
Group CO Line Buttons <sup>2</sup>	N/A	64	96
Pooled CO Line Buttons <sup>2</sup>	32	32	50
CO Group and Pooled Line Buttons <sup>2</sup>	N/A, 32	64	96
Door Unlock Buttons	24	32	64
Flexible Telephone Buttons	3200	3200	7000
Line and DN Buttons in use at the same time	96	1440	3360
Message Waiting Registration (DNs with MW)	130	130	230
Multiple Appearances of DN on Telephones	2300	2300	4200
Night Transfer Buttons	24	32	64
One Touch Buttons	1600	1600	3500
Primary Directory Numbers [PDNs] per system	30	72	160
Phantom Directory Numbers [PhDNs] per system	288	288	640
[PhDNs] with Message Waiting Indication LED	18	18	38

1. This is the number of unique CO Line Buttons (i.e., Line 1, Line 2, etc.). The total number of CO Line Buttons can not exceed the Flexible Telephone Button limit. Example: If Line 1 button appears on 10 telephones, it counts as one button.
2. This is the total number of all GCO or Pooled Line Buttons allowed in a system. Example: If the GCO1 button appears on 10 telephones, it counts as 10 buttons.

**Table 54 System Feature Capacities for Strata CIX40, CIX100 and CIX200**

Features	CIX40	CIX100 Base & Expansion	CIX200 Base and Expansion
Pilot DN	90	90	200
Advisory LCD Messages (Set on a Telephone)	1	1	1
Advisory LCD Messages Lists (per System)	10	10	10
Attendant Groups	1	1	1
Call Accounting SMDR Interface <sup>1</sup>	1	1	1
Call Forward, System CF Patterns	4	4	10
Call Park Orbits (General)	14	14	32
Call Park Orbits (Individual)	56	56	96
Minimum / Maximum Caller ID per Station	Minimum: 10; Maximum: 100		
Maximum number of Stations that can have Caller ID/ANI/ CNIS Numbers stored (Call History records)	66	66	100
	Up to 660/ system	Up to 660/ system	Up to 1000/ system
CO Line Groups - Incoming Line Groups (ILG)	11	32	50
CO Line Groups - Outgoing Line Groups (OLG)	11	32	50
Outgoing Line Groups (OLG) Members per system (Trunks + ISDN Line Service Index)	96 (No ISDN)	96	144

**Table 54 System Feature Capacities for Strata CIX40, CIX100 and CIX200 (continued)**

Features	CIX40	CIX100 Base & Expansion	CIX200 Base and Expansion
Conference Circuits	64	64	64
Conferencing (three-parties simultaneously) <sup>2</sup>	20	20	20
Conferencing (eight-parties simultaneously) <sup>2</sup>	8	8	8
Conference Party types (up to 8 total lines + stations) <sup>2</sup>	6 lines max. 8 stations max.	6 lines max. 8 stations max.	6 lines max. 8 stations max.
Two-CO Line simultaneous Connection <sup>2</sup> (Two party only, no telephone or VM port)	5	32	48
Conference/Line Volume Adjustment (PAD) Groups	6	6	10
DID Numbers for Calling Number ID/system	N/A <sup>3</sup>	225	500
DNIS/DID Network Routing Numbers (8~32 digits)	N/A <sup>3</sup>	200	400
DNIS/DID Numbers (total 4~7 digits)	N/A <sup>3</sup>	450	1000
DNIS/DID Numbers (4~7 and 8~32 digits)	N/A	450	1000
Network DNs	3000	3000	3000
DTMF Receivers <sup>4</sup>	16	16	16
E911 Groups	8	8	8
Emergency Call Groups	8	8	8
Hunt Groups (Serial/Circular/Distributed combined)	16	90	200
Hunt Group Size (DNs per group)	18	72	160
Hunt Group Stations (per system)	18	360	800
ISDN Line Service Indexes	N/A	32	48
Multiple Call Ring Group	16	16	32
Night Bell Control Relay per tenant <sup>5</sup>	1	1	1
Night Transfer Control Relay per tenant <sup>5</sup>	1	1	1
Off-hook Call Announce Handsets (simultaneous)	20	20	20
Off-hook Call Announce to Telephone Speakers <sup>6</sup>	23 IPT shared 12 IPT dedicated	72	112
Page Mute External BGM Control Relay <sup>5</sup>	1	1	1
Page Zone Relays <sup>5</sup>	N/A	4	8
Page Groups (Phones with or without External Zones)	4	4	8
Paging – (Group Page – simultaneous stations paged)	24	72	120
Pickup Groups	5	5	10
Ring Tones (External Call Ring Tones for DPs and IPTs)	10	10	10
Ring Tones (Internal Call Ring Tones for DPs and IPTs)	10	10	10
Speed Dial - Station SD numbers per system <sup>7</sup>	1080	1080	2400
Speed Dial - System SD numbers per system	800	800	800
Strategy ES / iES 32 / GVPH / LVMU / IVP8 systems per system <sup>8</sup>	1	1	1
Tenants	8	8	8
Destination Restriction Level (DRL) Classes	16	16	16
Verified Account Codes	135	135	300
Voice Mail SMDI Interface <sup>1</sup>	1	1	1



**Table 54 System Feature Capacities for Strata CIX40, CIX100 and CIX200 (continued)**

Features	CIX40	CIX100 Base & Expansion	CIX200 Base and Expansion
CSTA Device Monitors	512	512	512
CSTA Call Monitors	320	320	320

1. SMDI and SMDR may require BSIS serial port or LAN interface.
2. Conference circuits are used dynamically, so the maximum number of simultaneous conferences is affected by the number of conference members in each conference. The total number of members in simultaneous conferences cannot exceed the total number of conference circuits. Each conference can have up to eight members. Two CO line connections do not require a conference circuit.
3. N/A means Not Available
4. DTMF receivers are required for standard touch tone telephones, voice mail integration, Tie, DID and DISA lines.
5. An option BIOUS is required for up to four zone page relays and four control relays on the CIX100, CIX200 and CIX670 processor. One control relay and one 600 ohm page output is provided on board the CIX100 and CIX200 processor but not the CIX670 processor.
6. On Digital telephones Speaker OCA capacity is determined by 2B channel slot availability and power supply. CIX40 supports Speaker OCA (S-OCA) on IP5000-series and IPT2000-series telephones only and not on digital telephones. S-OCA requires the DOCA-1A option in DP5000-series digital telephones, but not in IP telephones. Speaker OCA on IP telephones require a MIPU, LIPU or GIPU, GIPH installed in the Strata CIX. Each IP telephone with Speaker OCA requires two IP channels on the MIPU / LIPU or GIPU / GIPH but only requires one IP endpoint license. The IP OCA channel is only used while the S-OCA call is in progress so it can be reserved or shared with other telephones for S-OCA but cannot be used as a dedicated IP channel for another telephone or Strata Net channel. DP5008 and IP2000-series telephones do not support Speaker OCA; all other current Toshiba telephones support S-OCA.
7. Up to 100 Station SD numbers, allocated in increments of 10, can be programmed per station.
8. CIX40 supports only the GVPH voice mail systems internally, and the Strategy ES externally.

**Table 55 Strata CIX1200 and CIX670 Cabinet and Slot Capacities**

Cabinets/Slots/Ports	CIX1200 EXP. B HCTU+HEXBU	CIX1200 EXP. A HCTU+HEXAU <sup>1</sup>	CIX1200 BASIC HCTU	CIX670 Expanded Processor BCTU + BEXU	CIX670 Basic Processor BCTU
Cabinets	1 to 12	1 to 7	1 to 2	1 to 7	1 to 2
Universal slots	8 to 118 <sup>2</sup>	8 to 68	8 to 18	8 to 68	8 or 18
Maximum capacity of ports including Voice Mail ports (lines + stations)	1152	672	192	672	192

1. The port and cabinet capacity of HCTU/HEXAU is identical to CIX670 BCTU/BEXU, however, the memory capacity for numerous features has been expanded with the HCTU/HEXAU - for details see the following tables.
2. For 8 to 12 cabinet systems, RRCU cards will require up to 3 card slots in a base cabinet stack and up to three slots in expansion cabinet stack. Up to a system total of six card slots.

**Table 56 Strata CIX1200 and CIX670 Station/Peripherals System Capacities**

Stations	CIX1200 EXP. B HCTU+HEXB	CIX1200 EXP. A HCTU+HEXA	CIX1200 BASIC HCTU	CIX670 Expanded Processor BCTU + BEXU	CIX670 Basic Processor BCTU
DKT2000, 3000, 3200, 5000 series <sup>1</sup>	952	552	152	552	152
DKT2000, 3000, 3200, 5000 series per cabinet	72 (Base) 80 (Exp)	72 (Base) 80 (Exp)	72 (Base) 80 (Exp)	72 (Base) 80 (Exp)	72 (Base) 80 (Exp)
IPT telephones <sup>2</sup>	80 (Base) 80 (Exp) 1000 System	80 (Base) 80 (Exp) 560 System	80 (Base) 80 (Exp) 160 System	80 (Base) 80 (Exp) 560 System	80 (Base) 80 (Exp) 160 System
DAMA per Base cabinet <sup>1</sup>	55 DPs with 1 ADM 43 DPs with 2 ADMs	55 DPs with 1 ADM 43 DPs with 2 ADMs	57 DPs with 1 ADM 43 DPs with 2 ADMs	55 DPs with 1 DADM 43 DPs with 2 DADMs	55 DPs with 1 DADM 43 DPs with 2 DADMs
DADM per Expansion cabinet <sup>1</sup>	57 DPs with 1 ADM 45 DPs with 2 ADMs	57 DPs with 1 ADM 45 DPs with 2 ADMs	55 DPs with 1 ADM 45 DPs with 2 ADMs	57 DPs with 1 DADM 45 DPs with 2 DADMs	57 DPs with 1 DADM 45 DPs with 2 DADMs
IADM on IPT <sup>3</sup>	84/cabinet	80/cabinet	80/cabinet	80/cabinet	80/cabinet
IADM System Capacity	800/system	400/system	116/system	400/system	116/system
DKT2204-CT or 2304-CT	952	552	152	552	152
CIX Attendant Console	6	6	6	4	2
Door locks <sup>4</sup>	10	10	5	10	5
Door phone control boxes (DDCB)	8	8	3	8	3
Door phones	24	24	9	24	9
DSS consoles (DSS)	24 per System 8 per Station	24 per System 8 per Station	5 per System 5 per Station	15 per System 8 per Station	5 per System 5 per Station
Off-premise stations	944	544	144	544	144
BPCI used for TAPI only per cabinet	66	66	66	66	66
Total Stations (Digital/ Analog/IP combined)	1000	560	160	560	160
Standard Station	944	544	144	544	144
DTMF Receivers <sup>5</sup>	48	32	16	32	16
Calls existing at the same time	576	336	96	336	96

1. Limited by power factor

2. Limited by system traffic

3. Limited by the number of flexible buttons per system

4. Each Door lock reduces the number of Door Phones by one Door Phone and vice versa.

5. DTMF receivers are required for standard touch tone telephones, voice mail integration, Tie, DID and DISA lines.

**Table 57 Strata CIX1200 and CIX670 Line Capacities and Universal Circuit Card Slots**

Lines	CIX1200 EXP. B HEXBUR	CIX1200 EXP. A HEXAU	CIX1200 BASIC HCTU Only	CIX670 Expanded Processor BCTU + BEXU	CIX670 Basic Processor BCTU
CO lines – loop start (analog - 8 lines/slot)	440	264	96	264	96
CO lines – ground start (analog - 4 lines/slot)	440	264	72	264	72
DID lines (analog - 4 lines/slot)	440	264	72	264	72
Tie lines (analog - 4 lines/slot)	440	264	72	264	72
T1 lines (DS-1) <sup>1</sup>	440	264	96	264	96
ISDN PRI B channel lines <sup>2</sup>	440	264	96	264	96
Strata Net IP Channels <sup>3</sup>	440	264	96	264	96
SIP Trunks	440	264	96	264	96
SIP URI per system	1000	560	160	560	160
SIP Trunk Service Index	128	128	48	128	48
Total lines (Analog, T1, SIP Trunks, Strata Net, and ISDN PRI B channels combined)	440	264	96	264	96
Channel Groups	220	128	48	128	48
Number of groups w/ GCO Line buttons	220	128	50	128	50
Busy Tone Detectors	48	32	16	32	16

1. T1 lines can be loop start, ground start, Tie or DID (maximum 24 lines per unit, any type or combination).
2. PRI lines provide CO line services, including Strata Net Networking, Calling Party Number/Name, DID, Tie, POTS, FX and DIT.
3. IP Strata Net channels provides Strata CIX networking functionality.

**Table 58 Strata CIX1200 and CIX670 Digital and IP Telephone Station Buttons**

Station Buttons per System	CIX1200 EXP. B HEXBUR	CIX1200 EXP. A HEXAU	CIX1200 BASIC HCTU Only	CIX670 Expanded Processor BCTU + BEXU	CIX670 Basic Processor BCTU
Call Forward, Personal CF Buttons	1000	560	160	560	160
Caller ID (CLID) button (DP or IPT only)	1000	560	160	560	160
CO Line Buttons <sup>1</sup>	440	264	96	264	96
Group CO Line Buttons <sup>2</sup>	440	264	96	264	96
Pooled CO Line Buttons <sup>2</sup>	220	128	50	128	50
CO Group and Pooled Line Buttons <sup>2</sup>	440	264	96	264	96
Door Unlock Buttons	96	96	64	64	64
Flexible Telephone Buttons	48000	48000	7000	24000	7000
Line and DN Buttons in use at the same time	6000	6000	3360	3360	3360

**Table 58 Strata CIX1200 and CIX670 Digital and IP Telephone Station Buttons** (continued)

Station Buttons per System	CIX1200 EXP. B HEXB	CIX1200 EXP. A HEXA	CIX1200 BASIC HCTU Only	CIX670 Expanded Processor BCTU + BEXU	CIX670 Basic Processor BCTU
Message Waiting Registration (DNs with MW)	1344	1344	230	800	230
Multiple Appearances of DN on Telephones	27000	27000	4200	15000	4200
Night Transfer Buttons	192	192	64	128	64
One Touch Buttons	24000	24000	3500	12000	3500
Primary Directory Numbers [PDNs] per system	1000	560	160	560	160
Phantom Directory Numbers [PhDNs] per system	4000	4000	640	2240	640
[PhDNs] with Message Waiting Indication LED	192	192	38	128	38
ISDN DN - System Capacity	768	768	224	768	224
ISDN DN - Station Capacity (per station)	8	8	8	8	8

1. This is the number of unique CO Line Buttons (i.e., Line 1, Line 2, etc.). The total number of CO Line Buttons can not exceed the Flexible Telephone Button limit. Example: If Line 1 button appears on 10 telephones, it counts as one button.
2. This is the total number of all GCO or Pooled Line Buttons allowed in a system. Example: If the GCO1 button appears on 10 telephones, it counts as 10 buttons.

**Table 59 Strata CIX1200 and CIX670 System Feature Capacities**

Features	CIX1200 EXP. B HEXB	CIX1200 EXP. A HEXA	CIX1200 Basic HCTU Only	CIX670 Expanded Processor BCTU + BEXU	CIX670 Basic Processor BCTU
Pilot DN	256	256	200	256	100
Advisory LCD Messages (Set on a Telephone)	1	1	1	1	1
Advisory LCD Messages Lists (per System)	10	10	10	10	10
Attendant Groups	1	1	1	1	1
Call Accounting SMDR Interface <sup>1</sup>	1	1	1	1	1
Call Forward, System CF Patterns	48	48	10	32	10
Call Park Orbits (General)	96	96	32	64	32
Call Park Orbits (Individual)	576	336	96	336	96
Minimum / Maximum Caller ID per Station	Minimum: 10 Maximum: 100				
Maximum number of Stations that can have Caller ID/ANI/CNIS Numbers stored (Call History records)	600	600	200	200	100
	3000	3000	1000	Up to 2000/ system	Up to 1000/ system
CO Line Groups - Incoming Line Groups (ILG)	220	128	50	128	50
CO Line Groups - Outgoing Line Groups (OLG)	220	128	50	128	50

Table 59 Strata CIX1200 and CIX670 System Feature Capacities (continued)

Features	CIX1200 EXP. B HEXBU	CIX1200 EXP. A HEXAU	CIX1200 Basic HCTU Only	CIX670 Expanded Processor BCTU + BEXU	CIX670 Basic Processor BCTU
Outgoing Line Groups (OLG) Members per system (Trunks + ISDN Line Service Index)	660	392	144	392	144
Conference Circuits	128	96	64	96	64
Conferencing (three-parties simultaneously) <sup>2</sup>	40	30	20	30	20
Conferencing (eight-parties simultaneously) <sup>2</sup>	16	12	8	12	8
Conference Party types (up to 8 total lines + stations) <sup>2</sup>	6 lines max. 8 stations max	6 lines max. 8 stations max	6 lines max. 8 stations max	6 lines max. 8 stations max.	6 lines max. 8 stations max.
Two-CO Line simultaneous Connection <sup>2</sup> (Two party only, no telephone or VM port)	220	132	48	132	48
Conference/Line Volume Adjustment (PAD) Groups	32	32	10	32	10
DID Numbers for Calling Number ID/system	1500	1500	500	1000	500
DNIS/DID Network Routing Numbers (8~32 digits)	1500	1500	400	1000	400
DNIS/DID Numbers (4~7 digits)	3000	3000	1000	2000	1000
Network DNs	6000	6000	6000	3000	3000
DTMF Receivers <sup>3</sup> and Busy Tone Detectors	48	32	16	32	16
E911 Groups	8	8	8	8	8
Emergency Call Groups	8	8	8	8	8
Hunt Groups (Serial/Circular/Distributed combined)	1100	1100	200	640	200
Hunt Group Size (DNs per group)	1000	560	160	560	160
Hunt Group Stations (per system)	5000	5000	800	2800	800
ISDN Line Service Indexes	220	128	48	128	48
Multiple Call Ring Group	96	96	32	64	32
Night Bell Control Relay per tenant <sup>4</sup>	1	1	1	1	1
Night Transfer Control Relay per tenant <sup>4</sup>	1	1	1	1	1
Off-hook Call Announce Handsets (simultaneous)	40	30	20	30	20
Off-hook Call Announce to Telephone Speakers <sup>5</sup>	592	352	112	352	112
Page Mute External BGM Control Relay <sup>4</sup>	1	1	1	1	1
Page Zone Relays <sup>4</sup>	8	8	8	8	8
Page Groups (Phones with or without External Zones)	24	24	8	8	8
Paging – (Group Page – simultaneous stations paged)	120	120	120	120	120
Pickup Groups	48	48	10	32	10
Ring Tones (External Call Ring Tones for DPs and IPTs)	10	10	10	10	10
Ring Tones (Internal Call Ring Tones for DPs and IPTs)	10	10	10	10	10

**Table 59 Strata CIX1200 and CIX670 System Feature Capacities** (continued)

Features	CIX1200 EXP. B HEXBU	CIX1200 EXP. A HEXAU	CIX1200 Basic HCTU Only	CIX670 Expanded Processor BCTU + BEXU	CIX670 Basic Processor BCTU
Speed Dial - Station SD numbers per system <sup>6</sup>	8400	8400	2400	5600	2400
Speed Dial - Station SD numbers per Station (allocated in increments of 10)	Min: 0 Max: 100	Min: 0 Max: 100	Min: 0 Max: 100	Min: 0 Max: 100	Min: 0 Max: 100
Maximum stations with SD per system	840	840	240	560	240
Speed Dial - System SD numbers per system	800	800	800	800	800
Stratagy Voice Processing per system	1	1	1	1	1
Tenants	8	8	8	8	8
Destination Restriction Level (DRL) Classes	16	16	16	16	16
Verified Account Codes	4000	4000	3000	1000	300
Voice Mail SMDI Interface <sup>1</sup>	1	1	1	1	1
External Ring Repeat - to available stations	256	256	All	All	All
LCR Exception Table Size (Programs 521 and 522)	2500	2500	2500	1280	1280
Maximum number of digits in the LCR Modified Digits Table	19	19	19	19	19
Maximum number of LCR Route Plans	128	128	128	64	64
CSTA Device Monitors <sup>7</sup>	1152	1152	1152	512	512
CSTA Call Monitors <sup>8</sup>	560	560	560	320	320

1. SMDI and SMDR may require BSIS serial port or LAN interface.
2. Conference circuits are used dynamically, so the maximum number of simultaneous conferences is affected by the number of conference members in each conference. The total number of members in simultaneous conferences cannot exceed the total number of conference circuits. Each conference can have up to eight members. Two CO line connections do not require a conference circuit.
3. DTMF receivers are required for standard touch tone telephones, voice mail integration, Tie, DID and DISA lines.
4. An option BIOU is required for up to four zone page relays and four control relays on the CIX670 and CIX1200 processor.
5. On Digital telephones Speaker OCA capacity is determined by 2B channel slot availability and power supply. S-OCA requires the DOCA-1A option in DP5000-series digital telephones, but not in IP telephones. Speaker OCA on IP telephones require an MIPU or LIPU installed in the Strata CIX. Each IP telephone with Speaker OCA requires two IP channels on the MIPU / LIPU but only requires one IP endpoint license. The IP OCA channel is only used while the S-OCA call is in progress so it can be reserved or shared with other telephones for S-OCA but cannot be used as a dedicated IP channel for another telephone or Strata Net channel. DP5008 and IPT1020-SD and IP2000-series telephones do not support Speaker OCA; all other current Toshiba telephones support S-OCT.
6. Up to 100 Station SD numbers, allocated in increments of 10, can be programmed per station.
7. See ["Device Monitor Capacities for Strata CIX Systems"](#) on page 187.
8. See ["Device Monitor Capacities for Strata CIX Systems"](#) on page 187.

## Device Monitor Capacities for Strata CIX Systems

Applications including Strata ACD, Net Phone, Tracer, Taske, VCS, FeatureFlex, and System TAPI send requests to the Strata CIX system to monitor the status of the telephones using the respective applications. These requests are sent over the CSTA ethernet link connecting the application and the Strata CIX system. These requests can produce a heavy load on the CIX processor and LAN so there is a limit to the number of telephones and devices that can be setup for monitoring and how many can be active on a monitored call simultaneously. The capacity limits and a table listing how the telephone and device capacities are counted is provided below:

### CSTA Device Monitor Capacity Limits

The limits below apply to expanded and non-expanded CIX processor configurations.

- Total number of devices that can be monitored: CIX1200 = 1152; CIX40/100/200/670 = 512
- Total number of simultaneous device monitor calls: CIX1200 = 560; CIX40/100/200/670 = 320

**Table 60 Applications using CSTA Device Monitors**

Device Category		Number of CSTA device monitors required
1	ACD Agent or Supervisor only.	1 CSTA device monitor per agent or supervisor.
2	ACD Agent or Supervisor with Net Phone and/or Tracer or both.	1 CSTA device monitor per agent or supervisor.
3	Normal User with Net Phone and/or Tracer or both.	1 CSTA device monitor per user.
4	ACD Groups.	1 CSTA device monitor per group.
5	ACD Queue Announcement ports.	1 CSTA device monitor per port.
6	Extensions, Analog and T1 trunks/channels to be monitored by Taske.	1 CSTA device monitor each.
7	Attendant Consoles	1 CSTA device monitor per console.
8	VCS users	1 CSTA device monitor per VCS user.
9	Feature Flex users	1 CSTA device monitor when user is using one or more FF application.
10	System TAPI Service Provider application.	1 CSTA device monitor per TSP application user.
<b>Note</b> The total CSTA Device Monitors used is equal to the sum of the devices in each Device Category.		

This page is intentionally left blank.



# Index

---

## A

- abandoned call numbers, [179](#), [184](#)
- account codes, [91](#)
- ACD
  - basic features, [93](#)
  - enhanced features, [93](#)
  - server, [17](#), [27](#), [30](#), [92](#)
- ACTU3A, [16](#)
- ACTU3A-S, [16](#)
- add-on modules, [91](#)
  - capacities, [177](#)
- ADKU, [35](#), [158](#)
- ADM
  - limits, [14](#)
- advisory messages, [91](#)
- alarm notification, [92](#)
- alternate answer point, [92](#)
- AMDS (modem), [17](#), [27](#), [30](#)
- analog
  - hold, [114](#)
- ANI, [179](#), [184](#)
- ASTU, [36](#)
- attendant
  - centralized, [141](#)
  - console, [17](#), [27](#), [30](#), [60](#)
- automatic
  - busy redial, [92](#)
  - call distribution (ACD) server, [92](#)
  - callback, [94](#)
  - camp on, [101](#), [139](#)
  - hold, [114](#)
  - release from hold, [95](#)
  - release of incoming call, [95](#)

## B

- background music, [6](#), [16](#), [26](#), [29](#), [95](#), [132](#), [148](#)
- bandwidth, [124](#), [171](#)
- base cabinet
  - CIX, [19](#), [160](#)
  - CTX100, [17](#)
  - CTX670, [31](#)
- BCTU, [25](#), [26](#), [27](#), [28](#), [29](#), [30](#), [153](#), [177](#), [181](#), [183](#),

[184](#)

- BDKU, [35](#), [159](#)
- BEXU, [25](#), [26](#), [28](#), [29](#), [153](#), [181](#), [183](#), [184](#)
- BGM, [6](#), [16](#), [26](#), [29](#), [95](#), [132](#)
- BIOU, [39](#)
- BIPU, [159](#)
- BPTU, [38](#)
- broadband ethernet, [123](#)
- BSIS, [6](#), [17](#), [27](#), [30](#), [39](#)
- BSTU, [36](#)
- busy tone detectors, [178](#), [183](#)
- buttons, [179](#), [183](#)
  - program, [148](#)
- BVPU, [37](#)
- BWDKU1A, [159](#)

## C

- cabinet capacity
  - CIX100, [15](#)
  - CIX40, [9](#)
  - CIX670, [25](#), [28](#)
- cabling, [70](#)
- call
  - completion, [95](#)
  - control, [140](#)
  - forward, [96](#)
  - history, [98](#)
  - hold, [99](#)
  - park, [99](#)
  - park orbits, [179](#), [184](#)
    - park and page, [99](#)
  - record to voice mail, [151](#)
  - waiting, [100](#)
- called number display, [48](#), [58](#)
- caller ID, [101](#), [179](#), [184](#)
  - interface unit, [37](#)
- CAMA trunk, [38](#)
- cancel button, [102](#)
- capacities, [179](#), [183](#)
- centrex, [102](#)
- CIX attendant console, [17](#), [27](#), [30](#), [60](#), [177](#)
- CIX200

- base cabinet, 19
- expansion cabinet, 19
- Extender Cards, 24
- CIX40
  - smartmedia, 6
- class of service override, 134
- CNIS, 179, 184
- CO lines
  - capacities, 178, 183
  - groups, 179, 184
  - tandem, 104
- codec, 57
- compatibility
  - IP hardware, 125
- computer telephony integration (CTI), 103
- conference
  - calls, 103
  - capacities, 180
  - on-hold, 103
  - ports, 180
  - split/join/drop, 103
- connectors, 70
- consultation hold, 114
- continuous DTMF tone, 104
- coordinated numbering plan, 140
- cordless digital telephones, 52
  - DKT2204-CT, 53
  - DKT2304-CT, 53
- CSTA, 60
- CTI, 103

**D**

- DADM, 91
- DDCB, 63
- DDSS
  - limits, 14
- delayed ringing, 106, 132
- destination restriction, 106, 180, 186
- DHCP, 57
- diagnostics, 143
- dial directory, 106
- dialed number identification service, 107
- DID, 37, 107, 178, 183
- digital
  - telephones capacities, 177
- digital pad, 108
- digital telephone
  - limits, 14
- direct inward dialing, 37, 107
- direct inward system access, 108
- direct station selection
  - buttons, 110
- DISA, 108
- distinctive LED indicator, 109

- DIU
  - limits, 14
- DKT capacities, 177
- DKT2204-CT, 53, 177
- DKT2304-CT, 53, 177
- DND, 134
- DNIS, 107, 180
- do not disturb, 110
  - override, 134
- DOC-A1A, 49
- door locks, 177
- door phones, 63, 177
  - capacities, 177
  - lock control unit, 63
- DSL modem, 57
- DSS
  - buttons, 110
  - consoles, 177
- DTMF
  - receivers, 111
- DTMF receivers, 177

**E**

- E&M tie line unit, 39
- E911 CAMA trunk, 38
  - subassembly (RCMS), 38
- electrical requirements, 82
- eManager, 83
- emergency call, 111
- enhanced E911, 112
- environmental conditions (see hardware)
- ethernet connection, 17
- exclusive hold, 114
- executive override, 134
- expanded system, 27, 30
- expansion cabinet
  - CIX, 19, 160
  - CTX100, 17
  - CTX670, 19, 31
- external
  - page interface, 6, 16
  - page zones, 180, 185
  - speaker (HESB), 63
  - speaker page zones, 135

**F**

- fault finding, 143
- feature prompting with soft keys, 111
- FeatureFlex, 85
- flash button, 112
- flash memory, 6, 16, 26, 29
- flexible buttons, 148
- functional block diagram, 12, 40

## G

G.711 and G.729A, 57  
 G3 fax, 128  
 GCOCIH1A, 4, 5, 9, 10, 125, 161  
 GIPH, 117  
 GIPU, 117  
 ground/loop start interface unit, 38

## H

handset OCA stations, 180, 185  
 handsfree answerback, 113  
 headset, 113  
 hearing aid compatible, 113  
 HESB, 63  
 hold  
   analog, 114  
   automatic, 99, 114  
   consultation, 114  
   exclusive, 114  
 hot desk, 115  
 hot dialing, 114  
 hotline service, 116  
 hunt groups, 180

## I

iES32, 37  
 Internet, 140  
 intranet, 140  
 IP, 126  
   interface unit, 117  
   SoftIPT phone, 126  
   telephone, 54  
   user mobility, 122  
 IPT  
   Anywhere, 123  
   bandwidth and voice quality considerations, 171  
 ISDN, 63, 101, 130, 140  
   PRI, 130, 178, 183  
 ISP, 127  
 IVP8, 37  
 IVR voice assistant ODBC, 93

## J

join button, 103

## L

LAN, 57  
 large-scale integrated circuit, 5, 16, 26, 29  
 LCD telephones, 58  
 LCNU, 24  
 LCTU, 21, 22  
 least cost routing, 130  
 license control

  SoftIPT, 127  
 license requirements, 173  
 line  
   buttons, 131, 179, 183  
   capacities, 178  
 LIPS, 21  
 LIPU, 21, 117, 159  
 live system programming, 131  
 loop limits, 14  
 loop start CO line interface, 38  
 loop start line limits, 14  
 lost call treatment, 131  
 LPFU, 23  
 LSI, 5, 16, 26, 29  
 LSLU, 21, 23, 158

## M

MAC address, 57  
 maintenance modem  
   CTX100, 17  
   CTX670, 26, 27, 29, 30  
 MDFB, 63  
 Media Application Server  
   basic specifications, 81  
   Physical Installation, 81  
   Software Backup, 79  
 memory  
   smartmedia, 6, 16, 26, 29  
 message waiting, 132  
 microphone  
   external, 132  
 MIPU, 117  
 modem  
   cable/DSL, 57  
   CTX100 AMDS, 17  
   CTX670 AMDS, 27, 30  
 MOH, 6, 16, 26, 29, 95, 132  
 multiple call, 106, 132  
   ring group, 180, 185  
 multi-system networking, 140  
 music-on-hold, 6, 16, 26, 29, 95, 132  
 My Phone Manager, 84

## N

NAT compatible, 128  
 NAT firewall guidelines, 120  
 NAT general guidelines, 120  
 NAT router guidelines, 120  
 network SMDR, 142  
 networking, 140  
   multi-system, 140  
   requirements, 162  
 night  
   ringing over selected page zones, 135

transfer, 180, 185  
numbering plan, 140

## O

off-hook call announce (OCA), 133, 180, 185  
  speaker mode, 49  
off-hook camp-on, 133  
off-premises stations, 133, 177  
one touch buttons, 148, 179, 184  
override, 134  
  class of service, 134  
  do not disturb, 134  
  executive, 134  
  privacy, 134

## P

paging, 135  
  external speaker page zones, 135  
  external zones, 180, 185  
  max. simultaneous stations, 180, 185  
  night ringing, 135  
  telephone group, 135  
park and page, 99  
PCB  
  CO line, 37  
  IP compatibility, 125  
  station, 35, 39  
  universal slot, 35  
PDKU, 159  
peripherals, 45, 63  
phantom directory numbers, 179, 184  
pickup groups  
  capacities, 180, 185  
pocket PC, 126  
power  
  failure protection, 136  
Power Over LAN, 125  
primary directory numbers, 179, 184  
privacy, 136  
  override, 134  
privacy/non-privacy, 134  
processor  
  CIX100, 16  
  CIX100-S, 16  
  CIX670, 26, 29  
  PCB subassemblies, 6, 17, 27, 30  
program button, 148

## Q

QSIG, 38, 140, 178  
QSIG over IP, 128, 140, 171  
Quality of Service (QoS), 117, 124, 171

## R

rack mount cabinets, 32  
RCIS, 37  
RCIU2, 37  
RCMS, 38  
RCOS, 38  
RCOU, 38  
RDDU, 37  
RDSU, 159  
RDTU, 38  
record call to voice mail, 151  
remote expansion cabinet unit, 34, 38  
REMU, 39  
repeat last number dialed, 137  
RFDM, 132  
RGLU2, 38  
RGLU3, 38  
ring over busy, 137  
ring tones, 148, 169, 180, 185  
RMCU/RCMS, 38  
routing patterns, 141  
RPTU2, 38  
RRCU, 34, 38

## S

simplified message desk interface (SMDI)  
  see SMDI  
SIP trunking, 37, 118, 119, 129, 173, 178, 183  
smartmedia, 6, 16, 26, 29, 143  
SMDI, 6, 17, 27, 30, 150  
SMDR, 6, 17, 27, 30, 139, 140, 142  
softIPT phone, 126  
speaker  
  OCA stations, 180, 185  
  off-hook call announce, 49  
speed dial, 138, 180, 186  
split/join/drop, 103  
standard telephone, 177  
station  
  automatic release, 95  
  buttons, 179, 183  
  dimensions, 167  
  hunt groups, 180  
  hunting, 138  
station message detail recording (SMDR)  
  see SMDR  
Strata Net, 140, 171  
Stratagy  
  iES32, 37  
  IVP8, 37  
Stratagy ES/iES32, 151  
stutter dial tone, 132  
subassemblies, 6, 17, 27, 30  
system

- capacities
  - CIX100, 15
  - CIX40, 9
  - CIX670, 25, 28
- tones, 168
- system call forward, 96

## T

- T1/DS-1
  - interface unit, 38
  - lines, 178, 183
- tandem CO lines, 104
- TCP/IP, 26, 29
- telephone
  - battery backup, 14
  - capacities, 177
  - DSS buttons, 141
  - group paging, 135
  - types, 45
- telephones
  - DP5000-series, 45, 167
  - DP5008, 47
  - DP5018-S, 47
  - DP5022-SD, 47
  - DP5022-SDM, 47
  - DP5032-SD, 47
  - DP5122-SD, 47
  - DP5130-FSDL, 47
  - DP5130-SDL, 47
- tenants, 180, 186
  - services, 145
- terminal authentication, 57
- through dialing, 106
- tie lines, 178, 183
- Tilt Angles, 50
- toll restriction, 106
- traffic measurement, 145
- transfer, 144

## U

- uniform call distribution, 146
- universal slot PCBs & subassemblies, 35, 177
- user programming mode, 148

## V

- verified account codes, 180, 186
- video communication solution, 66
- virtual private network (see VPN)
- VLAN tagging, 149
- voice mail
  - centralized, 141
  - integration, 150
  - record call, 151
  - SMDI, 180

- soft keys, 151
- voice processing
  - iES32, 37
  - IVP8, 37
- voice/tone signaling, 150
- VoIP, 117
- volume control, 151
- VPN, 140

## W

- WAN, 57, 140
- Wi-Fi, 126
- wireless, 127

**This is the last page of the document.**